



INSTALLATION GUIDE



UNIRAC Code-Compliant Installation Manual

© 2022 by Unirac, Inc. All rights reserved.



INSTALLATION GUIDE

TABLE OF CONTENTS

PRO SERIES SYSTEM

PRO SERIES SYSTEM COMPONENTS	1
SYSTEM COMPONENTS	2-4
THERMAL BREAK	5
SYSTEM LAYOUT	6
ROOF ATTACHMENT & L-FEET	7
SPLICE	8
ATTACH RAIL TO L-FEET	9
MICROINVERTER MOUNTING	10
MICROINVERTER SYSTEM GROUNDING	11
SPLICE & THERMAL BREAK	12
STANDARD SYSTEM GROUNDING	13-15
ENDCLAMP, FIRST MODULE	16
BONDING MIDCLAMP	17
REMAINING MODULES	18
BONDING CONNECTION GROUND PATHS	19-20
TRIM AND END CAP INSTALLATION	21

STANDARD SERIES SYSTEM

SYSTEM COMPONENTS	22
END & MID CLAMPS	23
ATTACH RAIL TO L-FEET	24
ENDCLAMP & FIRST MODULE	25
BONDING MIDCLAMP & TRIM	26
REMAINING MODULES & TRIM	27
TRIM RETROFIT INSTALLATION	28
BONDING CONNECTION GROUND PATHS	29-30
CODE COMPLIANCE NOTES	31
MECHANICAL LOAD TEST	32
SYSTEM LEVEL FIRE CLASSIFICATION	33
COMPATIBLE MODULES	34-39
APPENDIX A: FLASHKIT PRO INSTALLATION	40
APPENDIX B: FLASHLOC COMP INSTALLATION	41
APPENDIX C: FLASHLOC DUO INSTALLATION	42
APPENDIX D: UAF END & MID CLAMP INSTALLATION	43-44
APPENDIX E: S-5! COMPONENTS INSTALLATION	45-47
APPENDIX F: SM BUTYL ATTACHMENT INSTALLATION	48-51

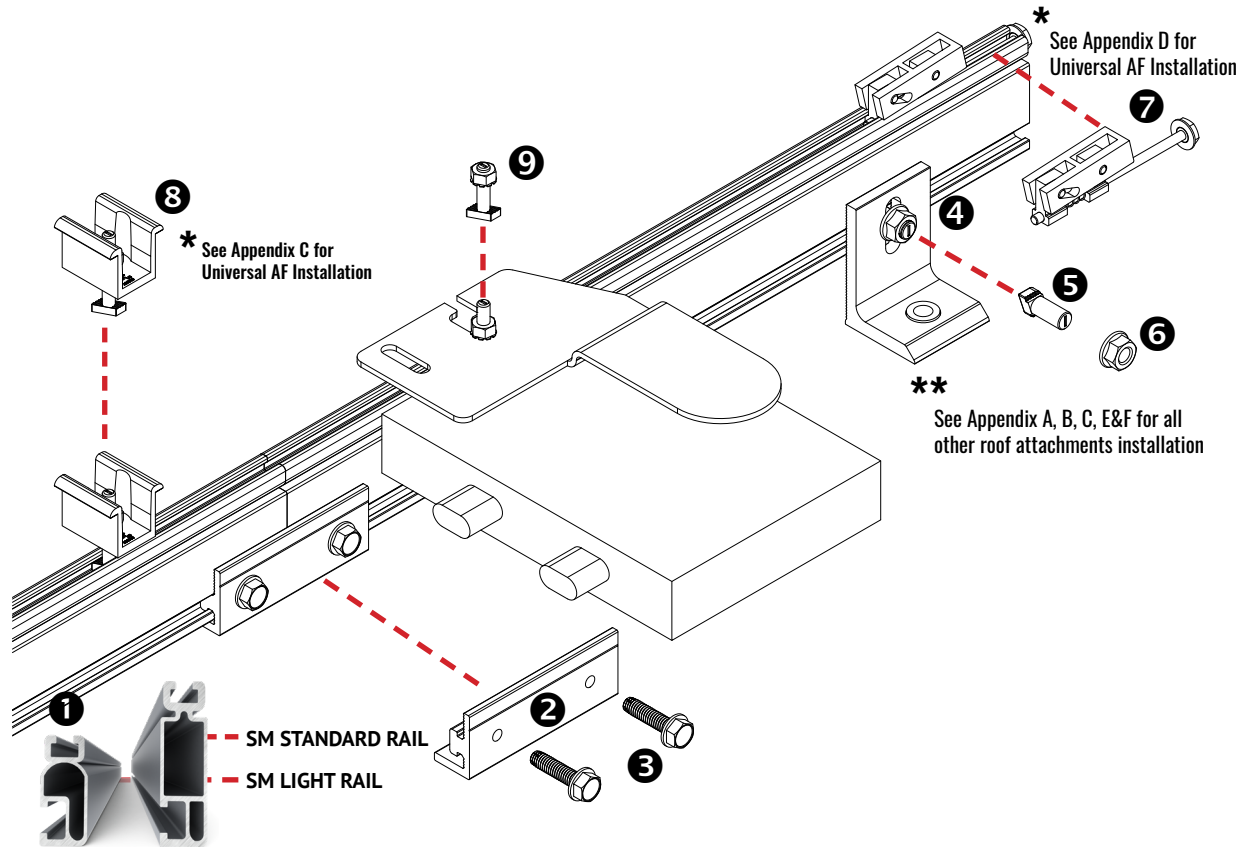

- 1 RAIL:** Supports PV modules. Use at least two per row of modules. Aluminum extrusion, available in mill, clear anodized, or dark anodized.
- 2 3 RAIL SPLICE:** Non structural splice joins, aligns, and electrically bonds rail sections into single length of rail. Forms a rigid splice joint, 4 inches long, preassembled with bonding hardware. Available in dark anodized or mill finish.
- 4 L-FOOT:** Use to secure rails through roofing material to building structure. Refer to loading tables or U-Builder for spacing.
- 5 L-FOOT T-BOLT:** (3/8" x 3/4" or 1") – Use one per L-foot to secure rail to L-foot. Stainless steel. Supplied with L-foot in combination with flange nut, provides electrical bond between L-foot and rail.
- 6 SERRATED FLANGE NUT:** Use one per L-foot to secure and bond rail to L-foot. Stainless steel. Supplied with L-foot.
- 7 MODULE ENDCLAMP:** Pre-assembled universal clamp that secures module to rail at module flange by tightening 1/2" hex head bolt.
- 8 MODULE MIDCLAMP:** Pre-assembled clamp provides module to module and module to rail bond. Aluminum clamp with stainless steel bonding pins and T-bolt. Available in clear or dark finish.
- 9 MICROINVERTER MOUNTING BOLT:** Pre-assembled bolt, nut, and captive star washer attaches and bonds microinverter to rail.

Wrenches and Torque		
	Wrench or Socket Size	Recommended Torque (ft-lbs)
Mid Clamp 8	1/2"	11
MLPE Mount 9	1/2"	10
End Clamp 7	1/2"	5
L-Foot to Rail 5	1/2"	30
Rail Splice 2	1/2"	10

Anti-Seize 6 9

Stainless steel hardware can seize up, a process called galling. To significantly reduce its likelihood:

1. Apply minimal lubricant to bolts only where indicated in installation process, preferably Anti-Seize commonly found at auto parts stores (Anti-seize has been factory applied to mid clamp bolts)
2. Shade hardware prior to installation, and
3. Avoid spinning stainless nuts onto bolts at high speed.

NOTE - POSITION INDICATOR: T-bolts have a slot in the hardware end corresponding to the direction of the T-Head.

NOTE - Pro Series Mid and End Clamps are single use only

NOTE - See GFT Installation Guide for installation of GFT EW BEAM SPLICE

RAILS

TYPE	PART NUMBER	DESCRIPTION
LIGHT RAIL	315168M	SM LIGHT RAIL 168" MILL
	315168D	SM LIGHT RAIL 168" DRK
	315208M	SM LIGHT RAIL 208" MILL
	315208D	SM LIGHT RAIL 208" DRK
	315246M	SM LIGHT RAIL 246" MILL
	315246D	SM LIGHT RAIL 246" DRK
STANDARD RAIL	320132M	SM RAIL 132" MILL
	310132C	SM RAIL 132" CLR
	320168M	SM RAIL 168" MILL
	310168C	SM RAIL 168" CLR
	310168D	SM RAIL 168" DRK
	320208M	SM RAIL 208" MILL
	310208C	SM RAIL 208" CLR
	320246M	SM RAIL 246" MILL
	310246C	SM RAIL 246" CLR
310246D	SM RAIL 246" DRK	
HEAVY DUTY RAIL	410144M	SMHD, RAIL 144" MILL
	410168M	SMHD, RAIL 168" MILL
	410204M	SMHD RAIL 204" MILL
	410246M	SMHD, RAIL 246" MILL
GFT EW BEAM	411166M	GFT EW BEAM 166" MILL
	411168M	GFT EW BEAM 168" MILL
	411246M	GFT EW BEAM 246" MILL

SYMBOL	DESCRIPTION
AL	ALUMINUM
CLR	CLEAR ANODIZED
DRK	DARK BRONZE ANODIZED
SS	STAINLESS STEEL
DRK SS	BLACK OXIDE COATED STAINLESS STEEL

LETTER	SUPPORTED MODULE THICKNESS
B	30MM -32MM
C	33MM -36MM
D	38MM -40MM
K	39MM -41MM
F	45MM -47MM
E	50MM -51MM

MID CLAMPS AND END CLAMPS

S.NO.	PART NUMBER	DESCRIPTION
1	302021C	SM ENDCLAMP B CLR AL
2	302021D	SM ENDCLAMP B DRK AL
3	302022C	SM ENDCLAMP C CLR AL
4	302022D	SM ENDCLAMP C DRK AL
5	302023C	SM ENDCLAMP D CLR AL
6	302023D	SM ENDCLAMP D DRK AL
7	302024C	SM ENDCLAMP E CLR AL
8	302024D	SM ENDCLAMP E DRK AL
9	302025C	SM ENDCLAMP F CLR AL
10	302025D	SM ENDCLAMP F DRK AL
11	302026C	SM ENDCLAMP K CLR AL
12	302026D	SM ENDCLAMP K DRK AL
13	302027C	SM BND MIDCLAMP BC SS
14	302027D	SM BND MIDCLAMP BC DRK SS
15	302028C	SM BND MIDCLAMP EF SS
16	302028D	SM BND MIDCLAMP EF DRK SS
17	302029C	SM BND MIDCLAMP DK SS

MID CLAMPS AND END CLAMPS (CONT.)

S.NO.	PART NUMBER	DESCRIPTION
18	302029D	SM BND MIDCLAMP DK DRK SS
19	302030D	SM MIDCLAMP PRO DRK
20	302030M	SM MIDCLAMP PRO MILL
21	302035M	SM ENDCLAMP PRO W/CAP
22	302045D	UNIVERSAL AF MID CLAMP DRK
23	302045M	UNIVERSAL AF MID CLAMP MILL
24	302050D	UNIVERSAL AF END CLAMP DRK
25	302050M	UNIVERSAL AF END CLAMP MILL

COMPONENTS

S.NO.	PART NUMBER	DESCRIPTION
1	303019M	BND SPLICE BAR PRO SERIES MILL
2	303019D	BND SPLICE BAR PRO SERIES DRK
3	304001C	L-FOOT SERR W/ T-BOLT, CLR
4	304001D	L-FOOT SERR W/ T-BOLT, DRK
5	009010S	SPLICE TEK SCRW #12-14X3/4" SS
6	009020S	BND T-BOLT&NUT 3/8" X 3/4" SS
7	009021S	BND T-BOLT&NUT 3/8" X 1" SS
8	004055M	FLASHKIT PRO, MILL 10 PK
9	004055D	FLASHKIT PRO, DRK 10 PK
10	004015D	SOLARMOUNT FLASHKIT PRO SB, DARK
11	004015M	SOLARMOUNT FLASHKIT PRO SB, MILL
12	004085M	FLASHLOC COMP KIT MILL
13	004085D	FLASHLOC COMP KIT DRK
14	004275M	FLASHLOC DUO MILL
15	004275D	FLASHLOC DUO DARK
16	003250W	#12-14 X 2.50 SCREW HDW SS SD

COMPONENTS (CONT.)

S.NO.	PART NUMBER	DESCRIPTION
17	004CT5H	SOLARHOOK UNIV SIDE MT CT5
18	004CT1H	SOLARHOOK SPANISH 7" BASE
19	004CT2H	SOLARHOOK SPANISH 9" BASE
20	004FLAT	SOLARHOOK FLASHING FLAT
21	004FLCT	SOLARHOOK FLASHING SPANISH FLCT
22	004AT1H	SOLARHOOK FLAT TILE
23	004ST1S	SOLARHOOK STONE COATED MT ST1
24	004AST1	SOLARHOOK ADJ STONE COATED ST1
25	004300M	STANDOFF 3" 2 PIECE AL, MILL
26	004300D	STANDOFF 3" 2 PIECE AL, DRK
27	004400M	STANDOFF 4" 2 PIECE AL, MILL
28	004400D	STANDOFF 4" 2 PIECE AL, DRK
29	004600M	STANDOFF 6" 2 PIECE AL, MILL
30	004600D	STANDOFF 6" 2 PIECE AL, DRK
31	004700M	STANDOFF 7" 2 PIECE AL, MILL
32	004700D	STANDOFF 7" 2 PIECE AL, DRK
33	330007M	AL STNDOFF 3/8" BOLT&EPDMWSHR
34	004013C	FLASH SOFT AL 18X18 OATEY 12836
35	008015S	WIRE BONDING CLIP W/ 8AWG
36	309003P	SM/SM LIGHT RAIL END CAP
37	004BUTYLM	SOLARMOUNT BUYTL ATT KIT #14s MILL
38	004BUTYLD	SOLARMOUNT BUYTL ATT KIT #14s DARK
39	M40002	GFT EW BEAM SPLICE
40	M31171	1/4" x 20 Self Drilling Screw (Buildex), ASTM A449/ SAE J429 (Similar Properties Confirmed by testing)
41	U-LUG	Grounding Lug Kit

MADE IN USA COMPONENTS LIST

COMPONENT	DESCRIPTION	STANDARD PART NUMBER	MADE IN USA PART NUMBER
BUTYL ATTACHMENT KIT	SOLARMOUNT BUTYL ATT KIT #14S MILL	004BUTYLM	004BUTYLM-US
	SOLARMOUNT BUTYL ATT KIT #14S DARK	004BUTYLD	004BUTYLD-US
RAIL	SM LIGHT RAIL 168" DRK	315168D	315168D-US
	SM LIGHT RAIL 185" DRK	315185D	315185D-US
	SM LIGHT RAIL 246" DRK	315246D	315246D-US
	SM LIGHT RAIL 168" MILL	315168M	315168M-US
	SM LIGHT RAIL 185" MILL	315185M	315185M-US
	SM LIGHT RAIL 246" MILL	315246M	315246M-US
	SM RAIL 185" DRK	310185D	310185D-US
	SM RAIL 246" DRK	310246D	310246D-US
	SM RAIL 185" MILL	320185M	320185M-US
	SM RAIL 246" MILL	320246M	320246M-US

EXPANSION JOINT USED AS THERMAL BREAK

Expansion joints prevent buckling of rails or system failure due to thermal expansion. Determine location of expansion joints prior to installation of L-feet and rails. To create a thermal expansion joint, set gap between rails that is sufficient for proper installation of end clamps and tooling to achieve required torque. A thermal break is required when a continuous length of spliced rails exceeds the length, in feet, shown in the table to the right. For additional concerns on thermal breaks in your specific project, please consult a licensed structural engineer.

Rails in expansion joint configurations are considered cantilevered and must follow the cantilever rule, on both sides of the expansion joint, which states that the maximum amount of rail that can be cantilevered is 1/3 the respective adjacent span. An expansion joint must not be spanned by a PV module. Installing a module over an expansion joint would defeat the goal of a thermal break and could result in damage to the array.

Bonding connection for splice used as a thermal break. Option shown uses two IlSCO lugs (Model No. GBL-4DBT P/N GBL-4DBT - see product data sheet for more details) and solid copper wire. Optional grounding may be achieved through Enphase microinverter. See page 12.

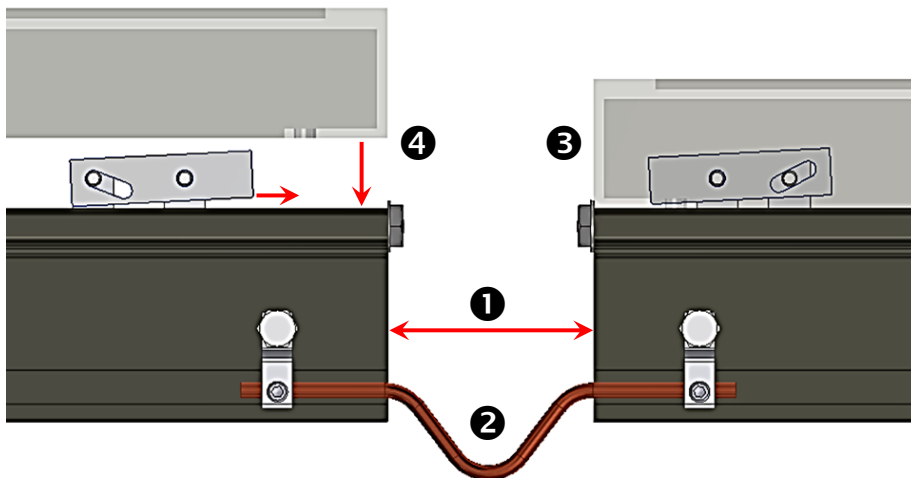

ΔT (°F)	Maximum Continuous Length (ft.) of Spliced Rails			
	Solarmount Standard		Solarmount Light	
	Attachment Span		Attachment Span	
	48"	72"	48"	72"
0-40	84	102	68	78
40-50	68	90	60	78
50-60	68	78	52	66
60-70	60	66	52	66
70-80	52	66	44	54
80-90	52	66	44	54
90-100	52	54	44	54
100-120	44	54	36	42
120-140	36	42	36	42

The values displayed are the maximum allowed rail length, in feet, without a thermal break.

These values apply only to the Flashkit Pro L-foot. For Flashloc Comp Mount or SM Butyl Mount or if your span is less than 48", refer to the Solarmount Design & Engineering Guide for max lengths of continuous rail before a thermal break is required.

The installer is responsible for determining the maximum temperature difference (ΔT) used to establish the maximum rail length, without expansion joint, at the install location.

As spans increase, so does the maximum reaction force that the rail exerts on the L-foot. It is the responsibility of the installer to ensure that Maximum Reaction Force does not exceed the shear capacity of the roof connection. See SM Design and Engineering Guide for corresponding reaction forces.

ΔT refers to the maximum difference in the temperature of the rail between installation and the extreme high or low temperature. The Extreme Annual Design Conditions table at the following url can be used as a reference when determining ΔT .

<http://ashrae-meteo.info/>

PLANNING YOUR SOLARMOUNT INSTALLATIONS

The installation can be laid out with rails parallel to the rafters or perpendicular to the rafters. Note that SOLARMOUNT rails make excellent straight edges for doing layouts.

Center the installation area over the structural members as much as possible. Leave enough room to safely move around the array during installation. Some building codes and fire codes require minimum clearances around such installations, and the installer should check local building code requirements for compliance.

The length of the installation area is equal to:

Standard Series:

- the total width of the modules,
- plus 1/4" inch for each space between modules (for mid-clamp),
- plus approximately 3" (1½ inches for each Endclamp)

Pro Series:

- the total width of the modules,
- plus 1" inch for each space between modules (for mid-clamp),
- plus 0 to 1" (0 to ½ inches for each Endclamp)

RAILS MAY BE PLACED PARALLEL OR PERPENDICULAR TO RAFTERS

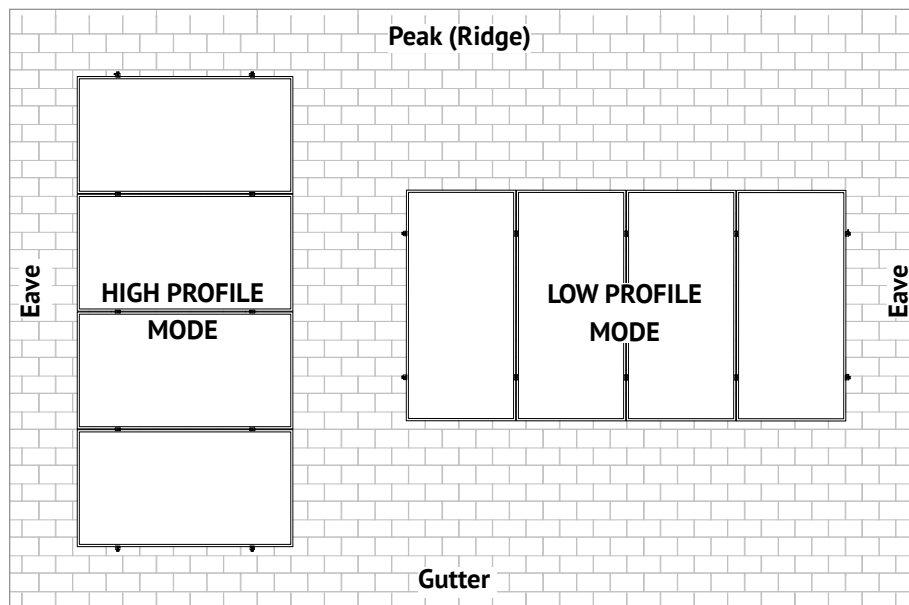

LAYING OUT L-FEET FOR TOP CLAMPS

L-feet, in conjunction with proper flashing equipment and techniques, can be used for attachment through existing roofing material, such as asphalt shingles, sheathing or sheet metal to the building structure.

Locate and mark the position of the L-feet lag screw holes within the installation area as shown below. Follow manufacturer module installation guide for rail spacing based on appropriate mounting locations

NOTE: For expansion joint requirements, refer to page 5. Rail Lengths and locations of l-feet for expansion joints will need to be determined at this stage in planning system layout.

If multiple rows are to be installed adjacent to one another, it is not likely that each row will be centered above the rafters. Adjust as needed, following the guidelines below as closely as possible.

Refer to Unirac Solarmount D&E Guide & U-Builder for allowable spans and cantilevers.

LAYOUT WITH RAILS PERPENDICULAR TO RAFTERS (RECOMMENDED)

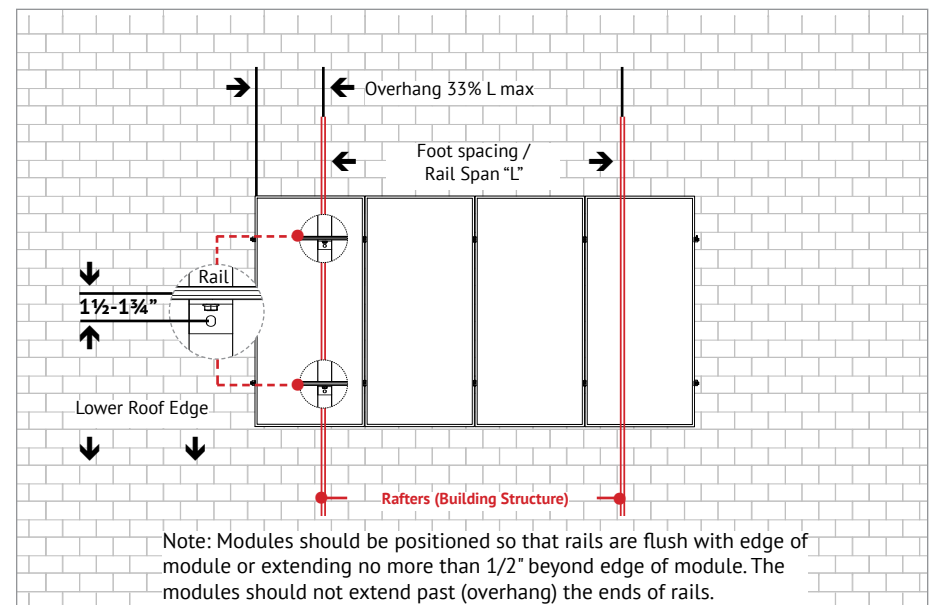

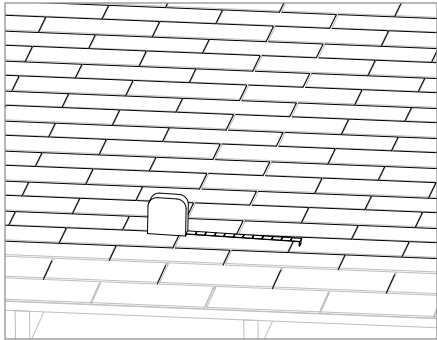

ROOF PREPARATION: Layout and install flashing at rafter locations determined per Design and Engineering Guide.

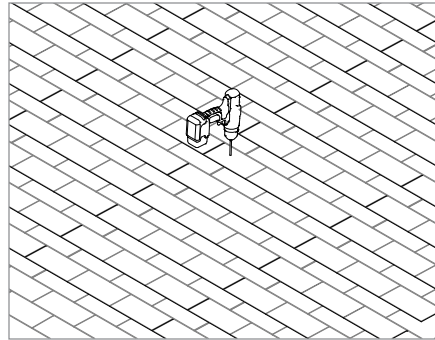

DRILL PILOT HOLES: Center the roof attachment over the rafter and drill a pilot hole(s) for the lag bolt(s).

NOTE: Determine lag bolt size and embedment depth.

Quick Tip: Pre-drill the pilot hole through the flat flashing lag bolt location for easier installation.

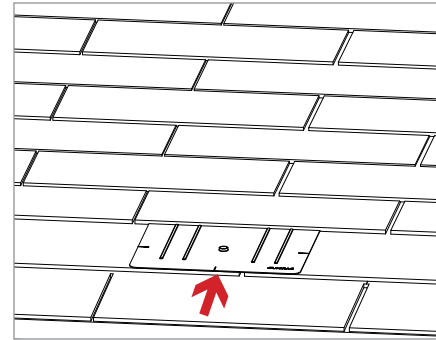

FLASHING INSTALLATION: Insert the flashing so the top part is under the next row of shingles and the hole lines up with the pilot hole.

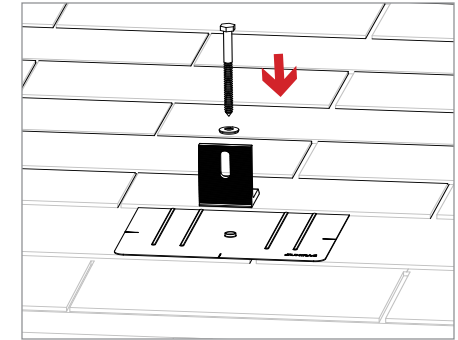

INSTALL LAG BOLTS & L-FOOT: Insert the lag bolt through the L-Foot in the order shown in the illustration. Verify proper orientation before tightening lag bolts.

For high snow load conditions, install the L-foot as shown above, and install the rail on the downslope face of the L-Foot

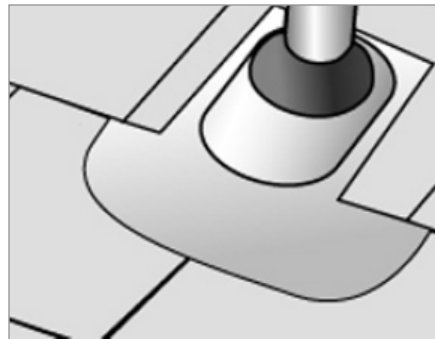
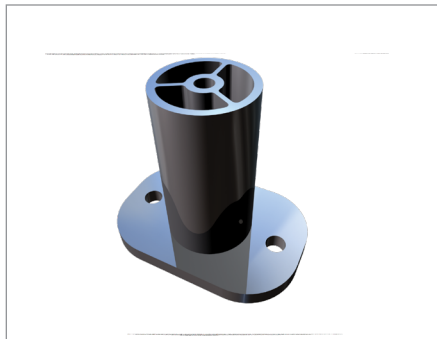

2 PIECE ALUMINUM STANDOFF WITH FLASHING & L-FOOT:

- If necessary cut an opening in the roofing material over a rafter to accommodate the flashing riser.
- Install the standoff, ensuring that both lag bolts are screwed into the rafter.
- Insert the flashing under the shingle above and over the shaft of the standoff. (No-Calk™ collar does not require sealing of the flashing and standoff shaft)
- Add L-Foot to top with bolt that secures the EPDM washer to the top of the standoff.

See [Standoffs Installation Manual](#) for Additional Details.

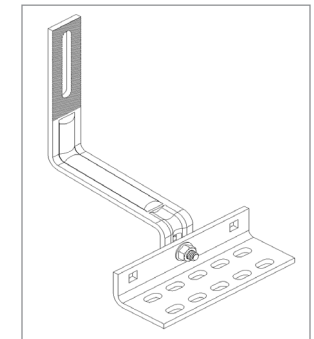
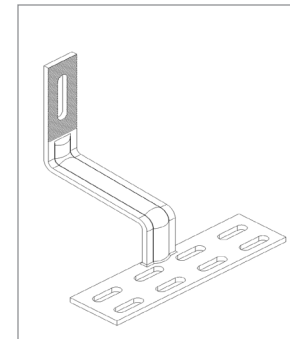
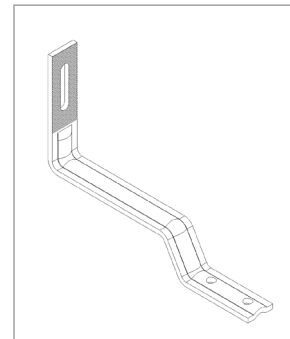

Side MOUNT SOLARHOOK:

- Remove or slide up the roof tile, position the roof hook above the roof rafter
- Place SolarHook in the middle of the underlying interlocking tile's valley. Drill 3/16 inch pilot holes through the underlayment into the center of the rafters. Securely fasten each tile hook to the rafters using included lag screws.
- Slide down or re-insert the tile.

See [Unirac Solarhook Installation Manual](#) for Additional Information.

SPLICE INSTALLATION (IF REQUIRED PER SYSTEM DESIGN)

If your installation uses SOLARMOUNT splice bars, attach the rails together before mounting to the L-feet/footings. Use splice bars only with flush installation and those that use low-profile tilt legs. A rail must be supported by more than one footing on both sides of the splice. There can be a gap between rails, up to 3/16" at the splice connections. To install, slide T-feature on splice into the T-slot on each rail, centering the splice between the two rails. Tighten each bolt until the bolt-head is flush against the splice and torqued to 10 ft-lbs. Installation is complete when the bonding hardware penetrates the opposite side of the rail and the assembly torque is achieved. T-bolts should not be placed less than a distance of 1" from the end of the rail regardless of a splice.

TORQUE VALUE

Hex head socket size 1/2" – Do not exceed 10 ft-lbs. Do not use Anti-Seize. See table on page 5 for max length of spliced rails. An expansion joint is required above the lengths published in the table.

Rails in splice joint configurations are considered cantilevered and must follow the cantilever rule, on both sides of the splice, which states that the maximum amount of rail that can be cantilevered is 1/3 the respective adjacent span. See table on page 5.

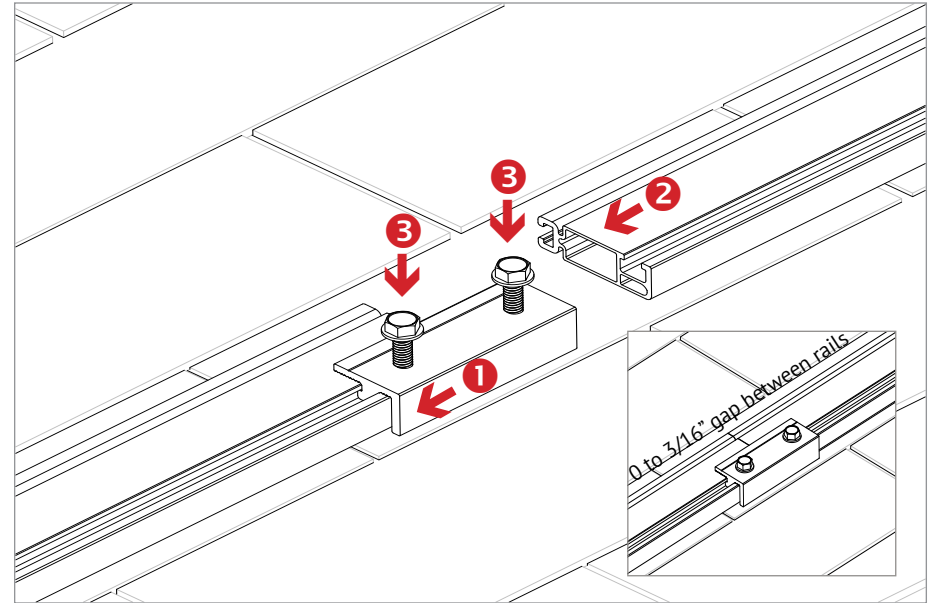

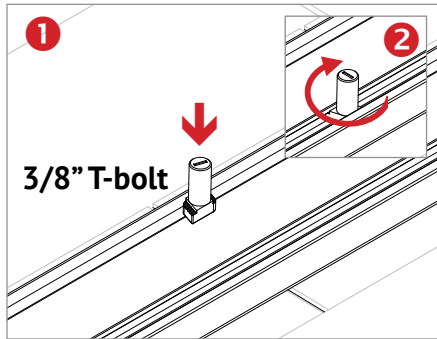

1 PLACE T-BOLT INTO RAIL & SECURE BOLT: Insert 3/8" T-bolt into rail at L-foot locations. Apply Anti-Seize to bolt. Rotate T-bolt into position.

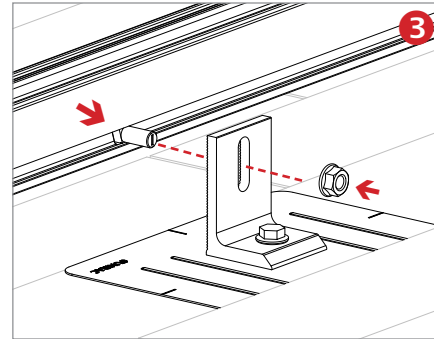

3 SECURE T-BOLT: Apply Anti-Seize to bolt. Rotate T-bolt into position.

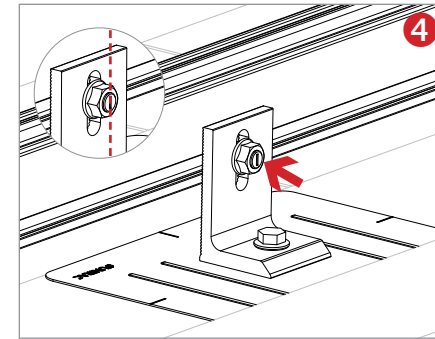

4 ALIGN POSITION INDICATOR: Hand tighten nut until rail alignment is complete. Verify that position indicator on bolt is vertical (perpendicular to rail)

TORQUE VALUE: 3/8" nut to 30 ft-lbs

ALIGN RAILS: Align one pair of rail ends to the edge of the installation area. The opposite pair of rail ends will overhang installation area. Do not Trim them off until the installation is complete. If the rails are perpendicular to the rafters, either end of the rails can be aligned, but the first module must be installed at the aligned end.

If the rails are parallel to the rafters, the aligned end of the rails must face the lower edge of the roof. Securely tighten all hardware after alignment is complete.

Mount modules to the rails as soon as possible. Large temperature changes may bow the rails within a few hours if module placement is delayed.

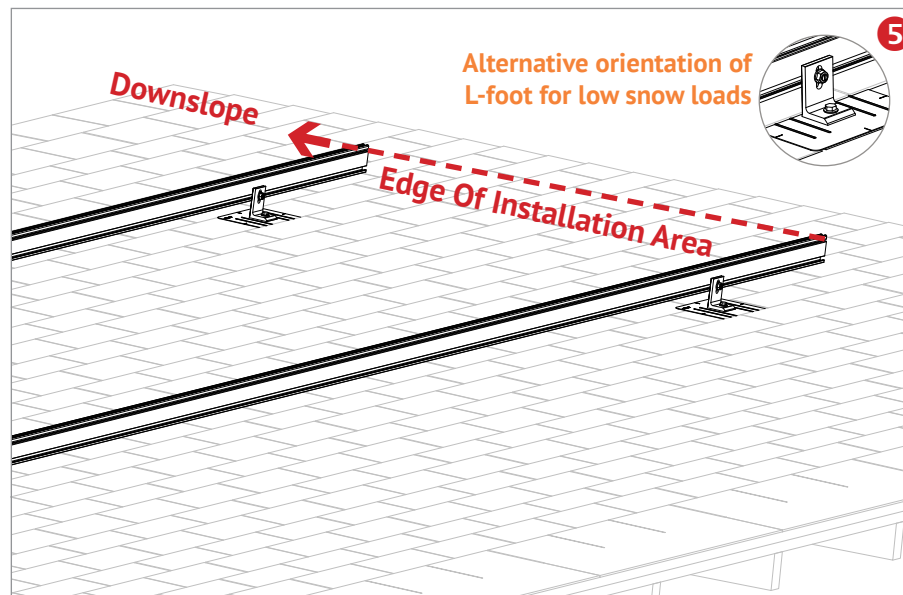

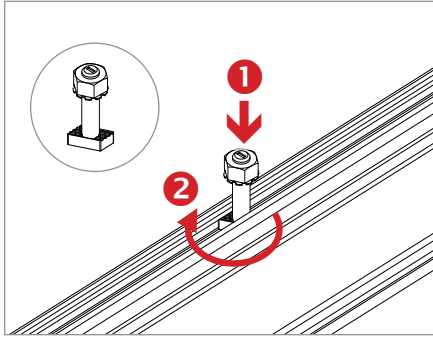

INSTALL MICROINVERTER MOUNT T-BOLT: Apply Anti-Seize and install pre-assembled 1/4" dia. bonding T-bolts into top 1/4" rail slot at microinverter locations. Rotate bolts into position.

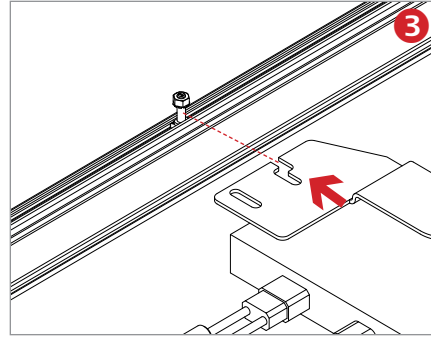

INSTALL MICROINVERTER: Install microinverter on to rail. Engage with bolt.

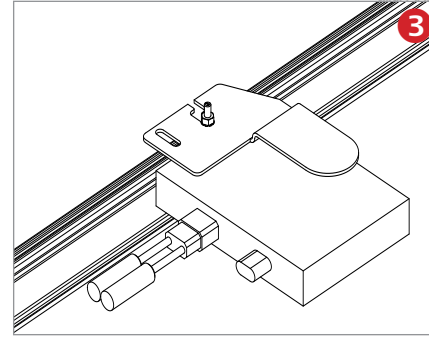

INSTALL MICROINVERTER:
TORQUE VALUE
 1/4" nut to 10 ft-lbs with Anti-Seize.

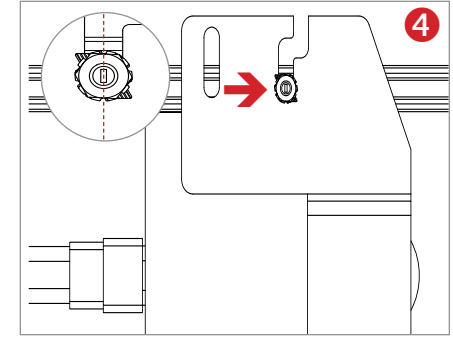

ALIGN POSITION INDICATOR: Verify that position indicator on bolt is perpendicular to rail.

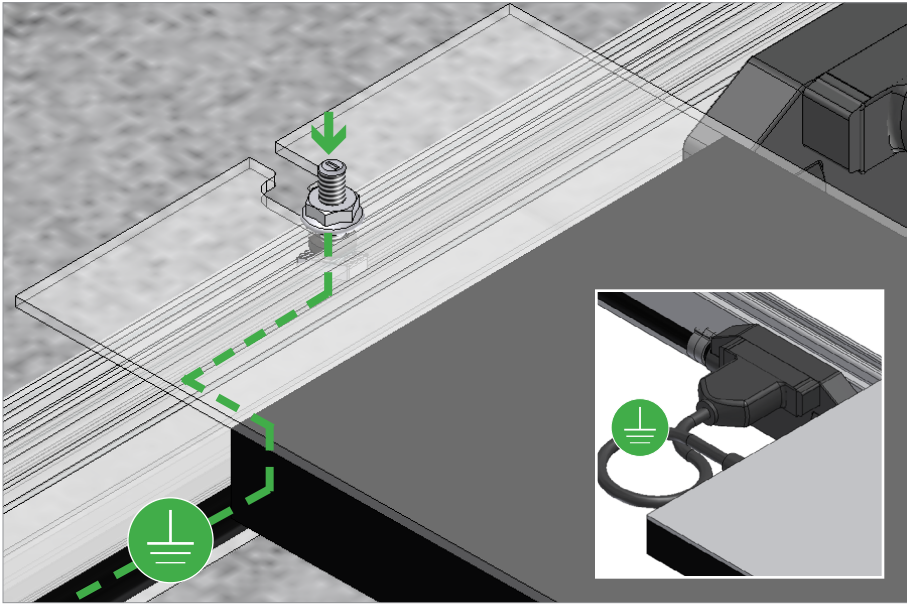

SM EQUIPMENT GROUNDING THROUGH ENPHASE MICROINVERTERS

The Enphase M215 and M250 microinverters have integrated grounding capabilities built in. In this case, the DC circuit is isolated from the AC circuit, and the AC equipment grounding conductor (EGC) is built into the Enphase Engage integrated grounding (IG) cabling.

In order to ground the SOLARMOUNT racking system through the Enphase microinverter and Engage cable assembly, there must be a minimum of three PV modules connected to the same trunk cable within a continuous row. Continuous row is defined as a grouping of modules installed and bonded per the requirements of this installation guide sharing the same two rails. The microinverters are bonded to the SOLARMOUNT rail via the mounting hardware. Complete equipment grounding is achieved through the Enphase Engage cabling with integrated grounding (IG). No additional EGC grounding cables are required, as all fault current is carried to ground through the Engage cable.



SOLARMOUNT INTEGRATED BONDING ADVANTAGE
 WITH SYSTEM GROUNDING THROUGH ENPHASE MICROINVERTERS AND TRUNK CABLES
LOSE ALL THE COPPER & LUGS



CONTINUOUS RAIL & ELECTRICAL BONDING SPLICE
Enphase Microinverter (MI) Requirements (Model No. M215 & M250)
3 Microinverters sharing same trunk cable & rails

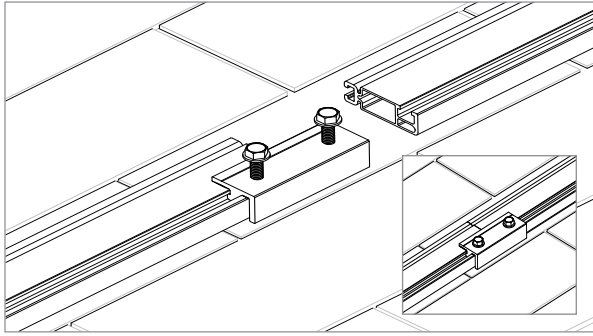
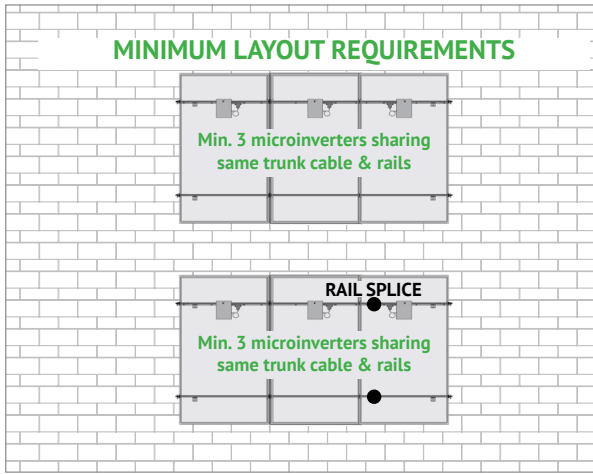

ELECTRICAL BONDING SPLICE

EXPANSION JOINT W/GROUNDING LUGS & COPPER JUMPER
Enphase Microinverter (MI) Requirements (Model No. M215 & M250)
3 or more Microinverters sharing same trunk cable & rails

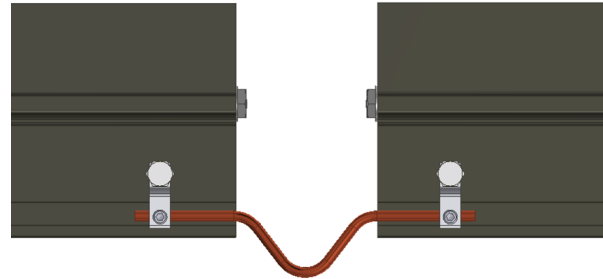
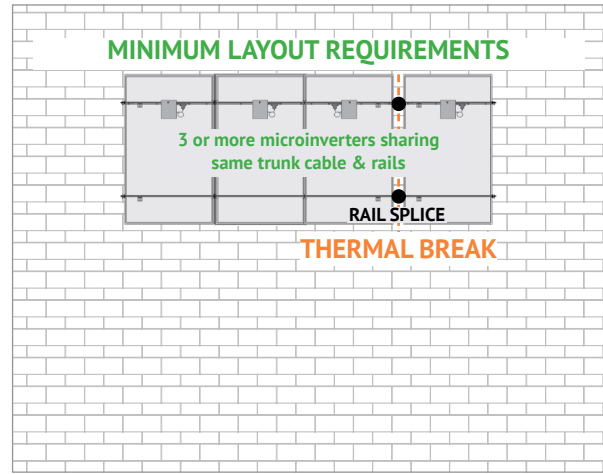

**EXPANSION JOINT USED AS THERMAL BREAK W/
GROUNDING LUGS & COPPER JUMPER**

EXPANSION JOINT W/O ELECTRICAL BONDING CONNECTION
Enphase Microinverter (MI) Requirements (Model No. M215 & M250)
Min. 3 Microinverters on each side of thermal break

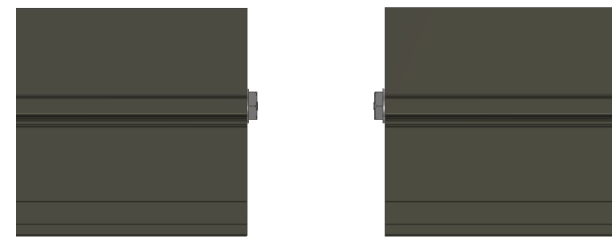
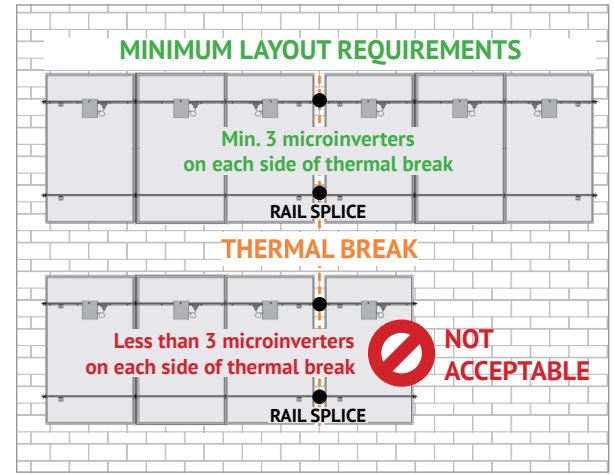

**EXPANSION JOINT USED AS THERMAL BREAK W/O
ELECTRICAL BONDING CONNECTION**

NOTE:
THE ABOVE IMAGES ARE SAMPLE CONFIGURATIONS TO ILLUSTRATE THE REQUIREMENTS FOR SM SYSTEM GROUNDING THROUGH ENPHASE MICROINVERTERS DESCRIBED ON page 11.

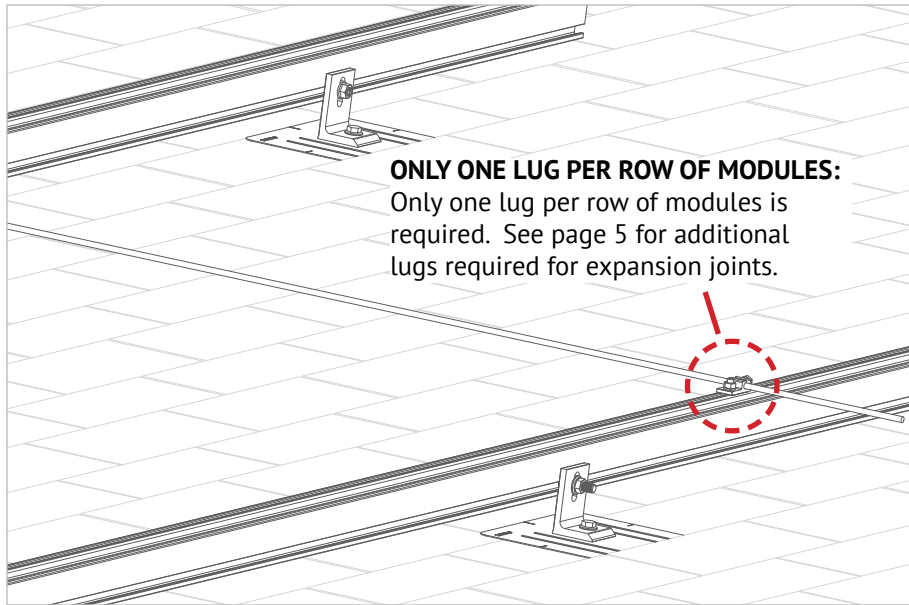

GROUNDING LUG MOUNTING DETAILS:

Details are provided for the Ground lug, WEEB and IlSCO products. The WEEBLug has a grounding symbol located on the lug assembly. The IlSCO lug has a green colored set screw for grounding indication purposes. The Ground lug is pre-assembled lug compatible with 0.25 inch T-Bolt slot rails. Installation must be in accordance with NFPA NEC 70, however the electrical designer of record should refer to the latest revision of NEC for actual grounding conductor cable size.

Required if not using approved integrated grounding microinverters

GROUNDING LUG - BOLT SIZE & DRILL SIZE			
GROUND LUG	Unirac P/N	BOLT SIZE	DRILL SIZE
Grounding Lug	U-LUG	1/4"	N/A - Place in Top SM Rail Slot
WEEB Lug	008002S	1/4"	N/A - Place in Top SM Rail Slot
ILSCO Lug	008009P	#10-32	7/32"

- Torque value for Grounding Lug is 10 ft-lbs.
- Torque value for WEEB and ILSCO Lugs varies depending on conductor size. See product data sheet for torque values.

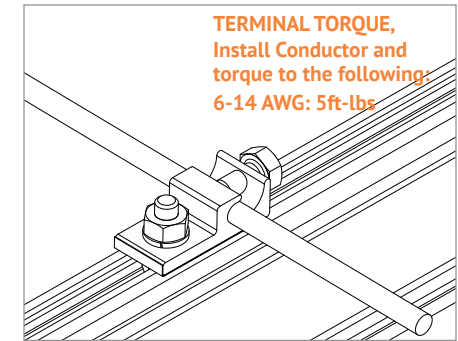
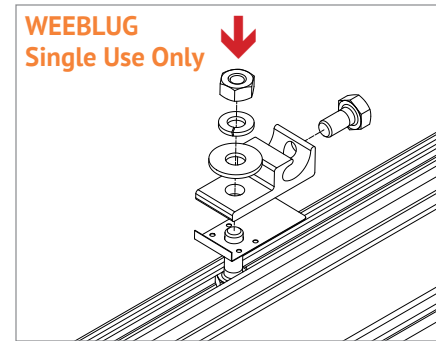

WEEBLUG CONDUCTOR - UNIRAC P/N 008002S:

Apply Anti Seize and insert a bolt in the aluminum rail and through the clearance hole in the stainless steel flat washer. Place the stainless steel flat washer on the bolt, oriented so the dimples will contact the aluminum rail. Place the lug portion on the bolt and stainless steel flat washer. Install stainless steel flat washer, lock washer and nut. Tighten the nut until the dimples are completely embedded into the rail and lug.

TORQUE VALUE 10 ft lbs.

See product data sheet for more details, Model No. WEEB-LUG-6.7

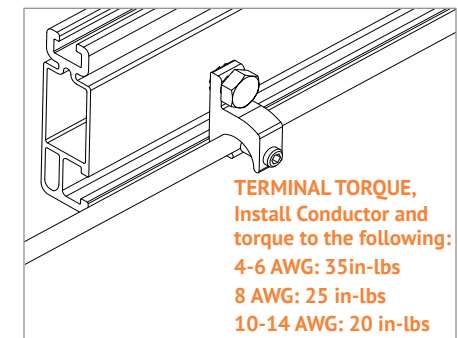
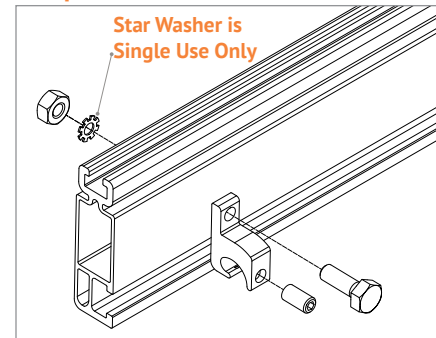

ILSCO LAY-IN LUG CONDUCTOR - UNIRAC P/N 008009P: Alternate Grounding Lug - Drill, deburr hole and bolt thru both rail walls per table.

TORQUE VALUE 5 ft lbs.

See ILSCO product data sheet for more details, Model No. GBL-4DBT.

NOTE: ISOLATE COPPER FROM ALUMINUM CONTACT TO PREVENT CORROSION

GROUNDING LUG (P/N: U-LUG) INSTALLATION STEPS:

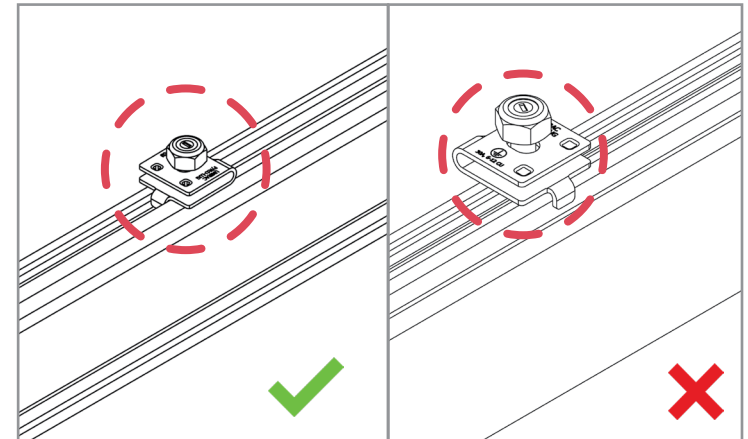
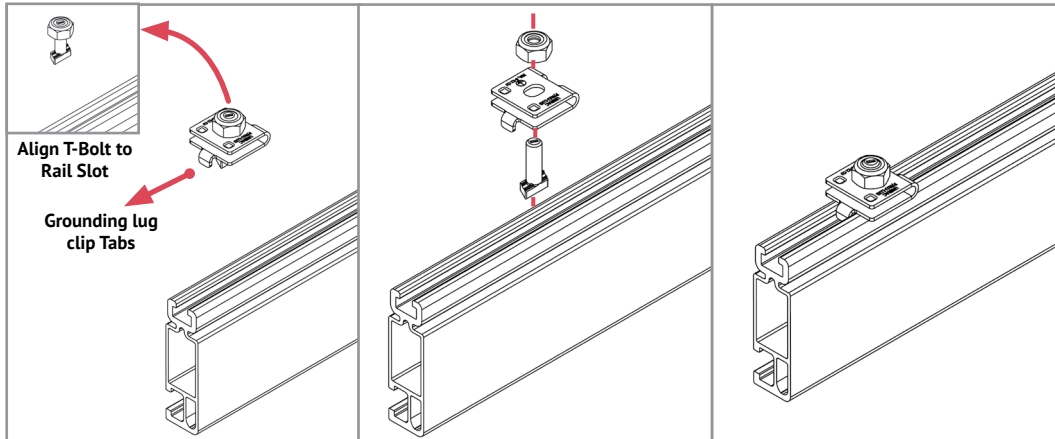

STEP 1: POSITION THE GROUNDING LUG

- Place the Grounding Lug on the rail with pre-assembled 1/4" T-bolt and nut.
- Ensure the Grounding Lug Clip tabs are positioned inside the rail.

**GROUNDING LUG CLIP TABS
INSIDE THE RAIL**

**GROUNDING LUG CLIP TABS
OUTSIDE THE RAIL**

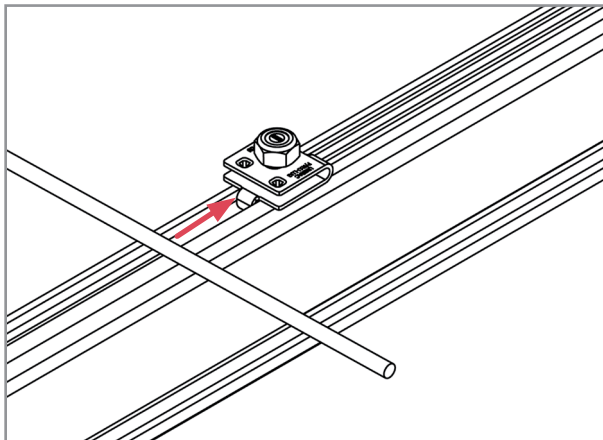

STEP 2: INSERT GROUNDING WIRE

- Insert the copper grounding wire (6-12 AWG) into the Grounding Lug Clip.

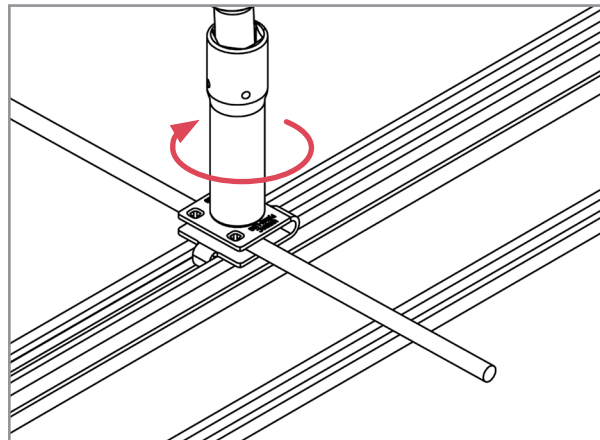

STEP 3: SECURE GROUNDING LUG TO RAIL

- Tighten the 1/4" nut to secure the Grounding Lug to Rail.

Torque the 1/4" nut to 10 ft-lbs.

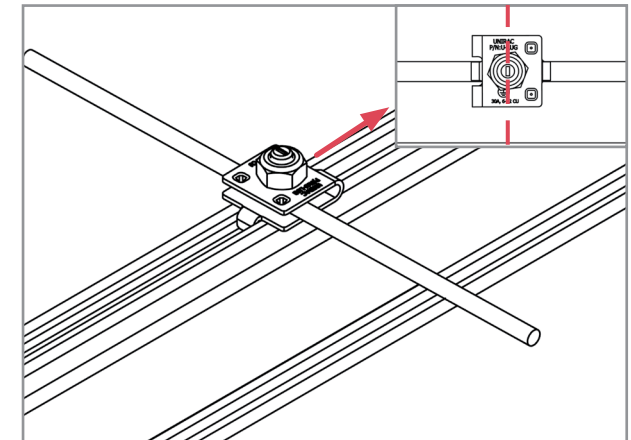

ALIGN POSITION INDICATOR

- Verify that the position indicator on the bolt is perpendicular to the rail.

**NOTE: 1. Follow the above instructions when attaching the Grounding Lug to the SM Light Rail.
2. The Grounding Lug is single use only.**

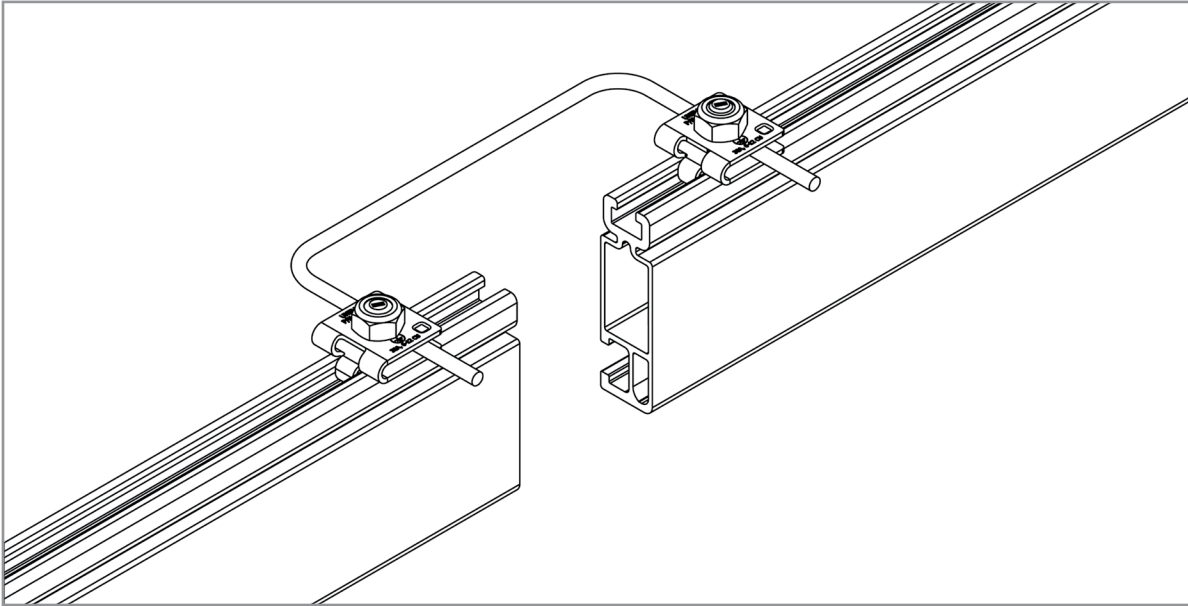

TO ESTABLISH EAST-WEST BONDING

- Place a Grounding Lug at one end of the rail, closer to the adjacent rail end
- Insert the grounding wire into the Ground Lug and tighten the 1/4" nut to secure both the Grounding Lug and the wire to the rail

Torque the 1/4" nut to 10 ft-lbs.

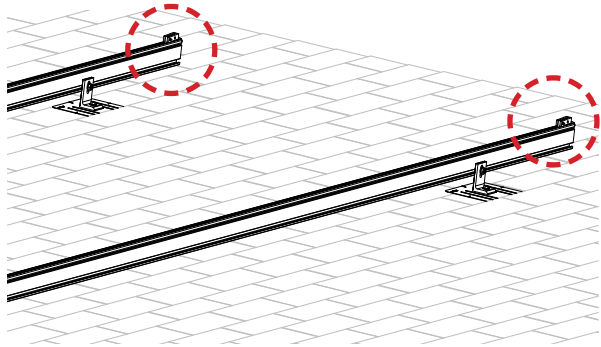

1

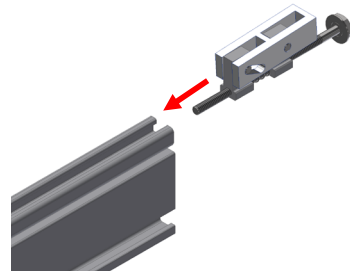

2

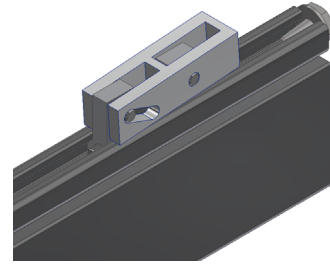

3

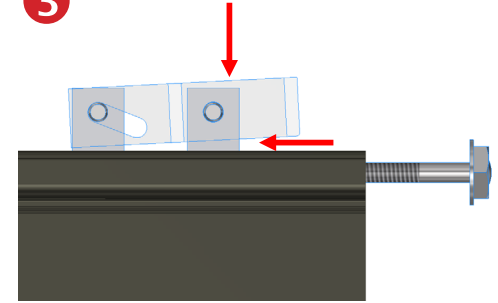

INSTALL MODULE END CLAMPS: The End clamp is supplied as an assembly with a 1/2" hex head bolt that is accessible at the ends of rails. The clamp should be installed on the rails prior to installing end modules.

INSTALL END CLAMPS ON RAIL: Slide end clamp on to rail by engaging the two t-guide brackets with the top slot of the rails. **Ensure bolt is extended as far as possible so that clamp is positioned at max. distance from end of rail.**

POSITION END CLAMPS: Slide end clamp assembly on to rail until bolt head engages with end of rail. **End clamps are positioned on rails prior to the first end module and prior to the last end module.**

NOTE: To assist insertion of clamp into rail slot, Pressure may be applied to top or side of bracket as shown. Do not force clamp into rail by pushing on bolt with excessive force.

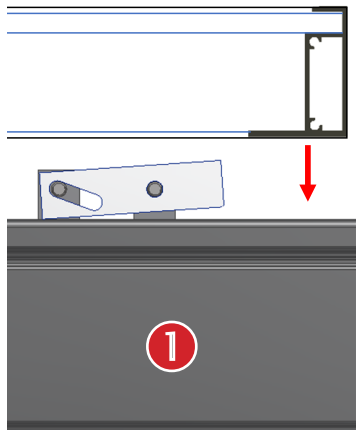

1

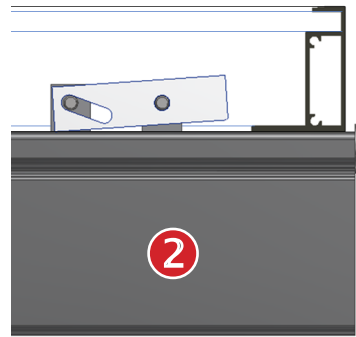

2

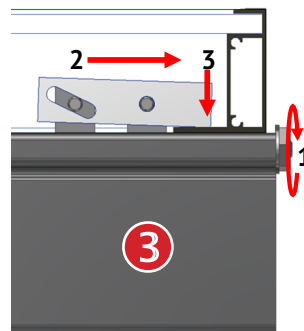

3

INSTALL FIRST MODULE: Install the first end module onto rails with the flange of the module frame positioned between end clamps at ends of rails.

ENGAGE CLAMP: While holding module in position and with flange in full contact with rail, rotate end clamp bolt until clamp engages with flange to provide clamp force.

To ensure bolt is not over-torqued, use low torque setting on drill or If using an impact driver, stop rotation as soon as impact action of driver begins.

TORQUE VALUE

End clamp bolt to 5 ft-lbs, No anti-seize

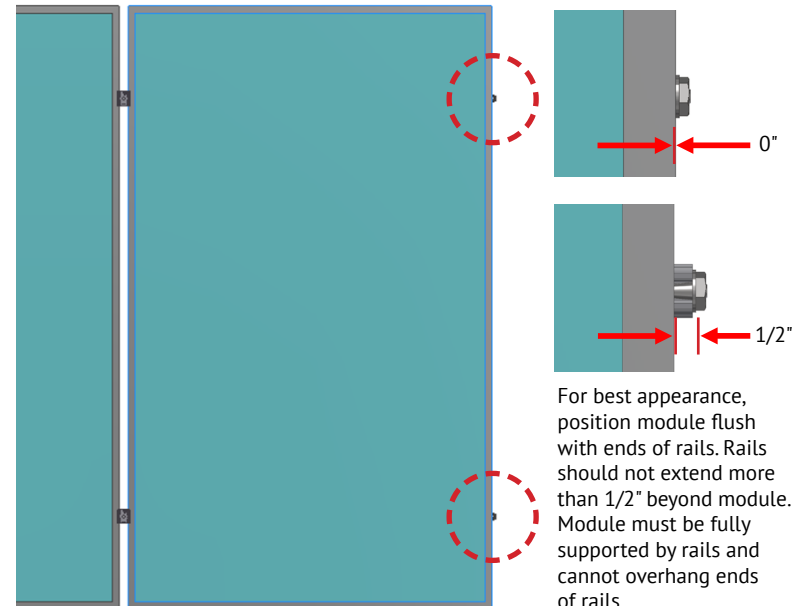

For best appearance, position module flush with ends of rails. Rails should not extend more than 1/2" beyond module. Module must be fully supported by rails and cannot overhang ends of rails.

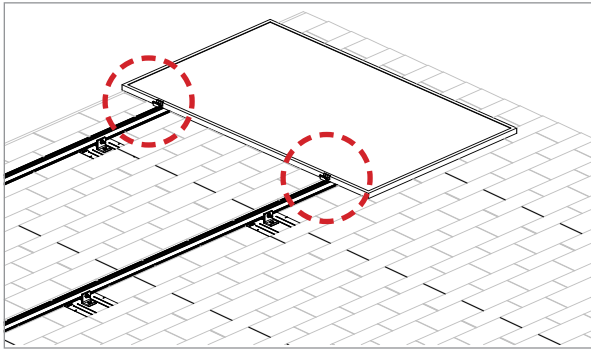

INSTALL MIDCLAMPS: Midclamp is supplied as an assembly with a T-bolt for module installation. Clamp assemblies may be positioned in rail near point of use prior to module placement.

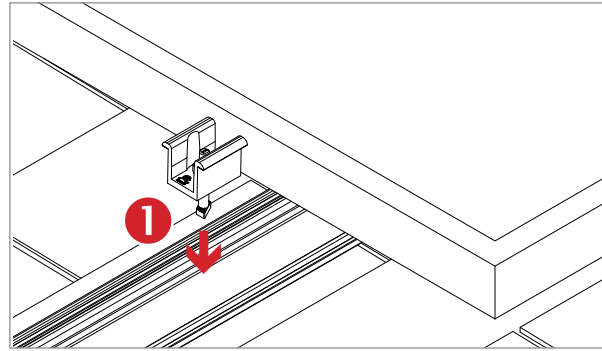

INSERT MIDCLAMP ASSEMBLY: Insert 1/4" T-Bolt into top slot of rail

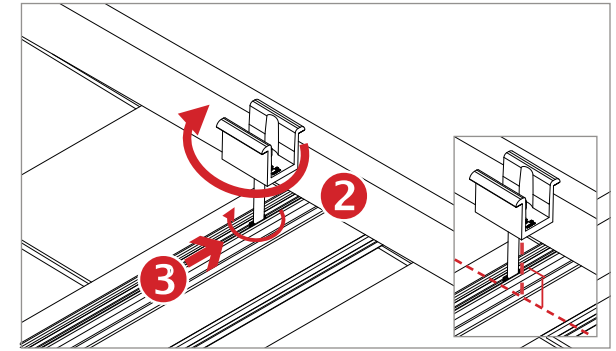

MIDCLAMP: Rotate midclamp assembly and slide until clamp is against module frame. Do not tighten nut until next module is in position. Ensure bolt is perpendicular to rail.

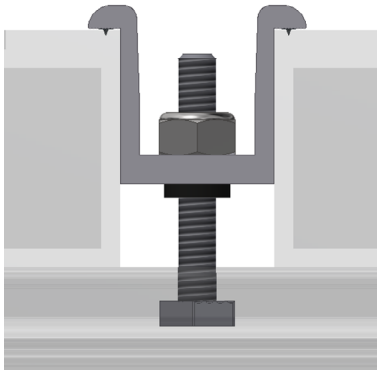

PLACE ADJACENT MODULE AGAINST CLAMPS: Modules must be tight against clamps with no gaps. Tighten nut to required torque.

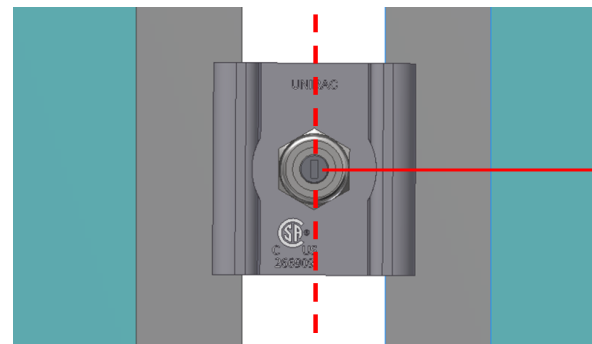

POSITION INDICATOR - SERRATED T-BOLT: Verify the T-bolt position indicator is perpendicular to the rail.

TORQUE VALUE: 11 ft-lbs. No anti-seize.

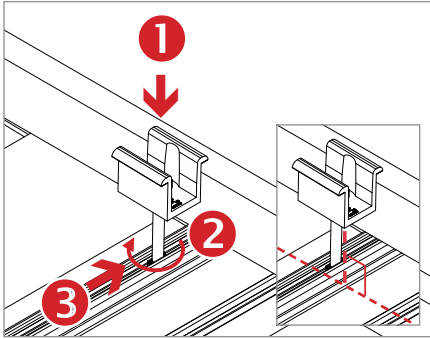

INSTALL REMAINING MID-CLAMPS:
 Proceed with module installation.
 Engage each module with previously positioned Midclamp assemblies.

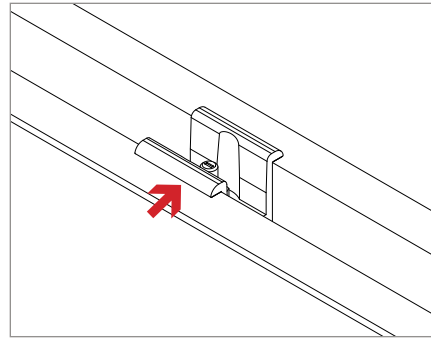

POSITION T-BOLT ALIGNMENT MARKS:
 Verify that the position indicator(s) & T-bolt shaft(s) are angled in the correct position. Tighten to final torque.

TORQUE VALUE: 11 ft-lbs. No anti-seize.

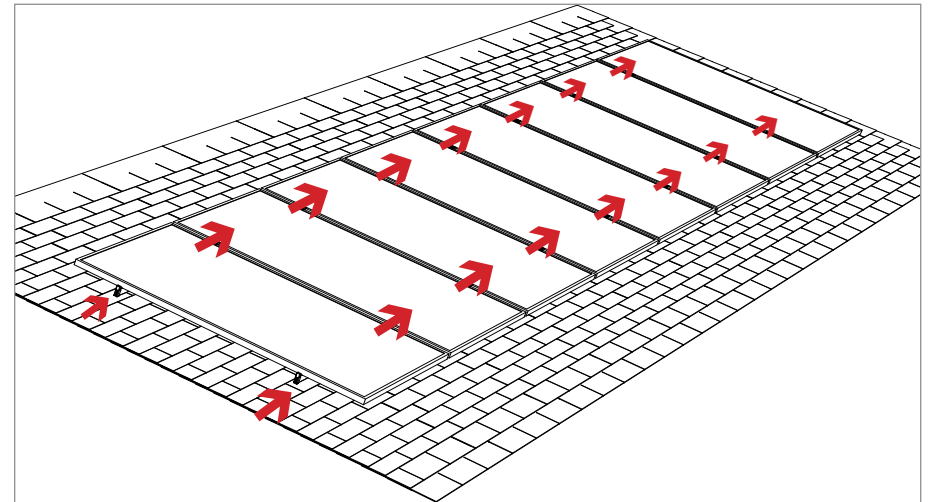

FINISH MODULE INSTALLATION: Proceed with module installation. Engage each module with the previously positioned clamp assembly:

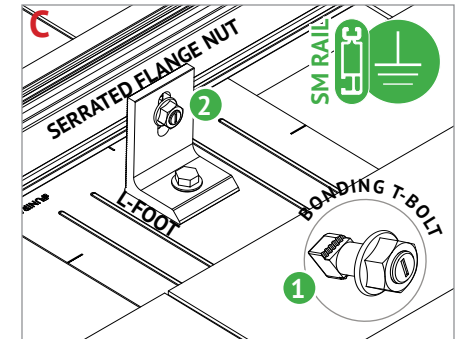
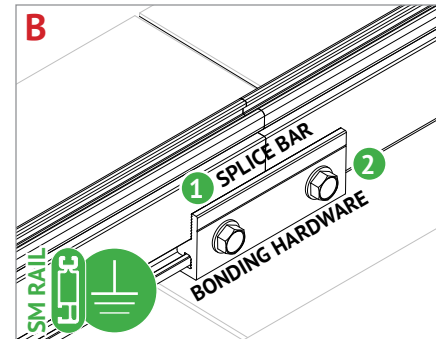
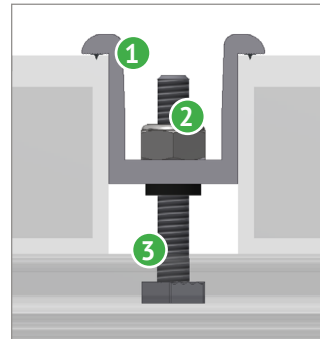
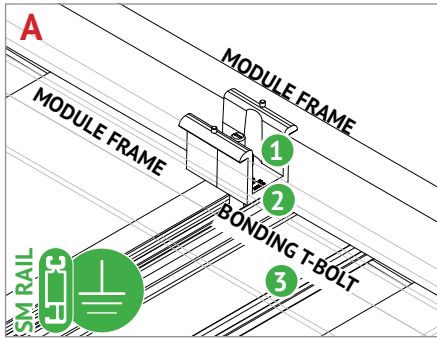

BONDING MIDCLAMP ASSEMBLY

- 1 Aluminum mid clamp with stainless steel bonding pins that pierce module frame anodization to bond module to module through clamp
- 2 Stainless steel nut bonds aluminum clamp to stainless steel T-bolt
- 3 Serrated T-bolt head penetrates rail anodization to bond T-bolt, nut, clamp, and modules to SM rail

BONDING MIDCLAMP ASSEMBLY

BONDING RAIL SPLICE BAR

- 1 Bonding Hardware creates bond between splice bar and each rail section
- 2 Aluminum splice bar spans across rail gap to create rail to rail bond. Rail on at least one side of splice will be grounded.

Note: Splice bar and bolted connection are non-structural. The splice bar function is rail alignment and bonding.

RAIL TO L-FOOT w/BONDING T-BOLT

- 1 Serrated flange nut removes L-foot anodization to bond L-Foot to stainless steel T-bolt
- 2 Serrated T-bolt head penetrates rail anodization to bond T-bolt, nut, and L-foot to grounded SM rail

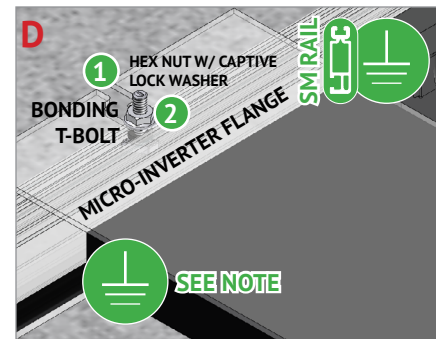
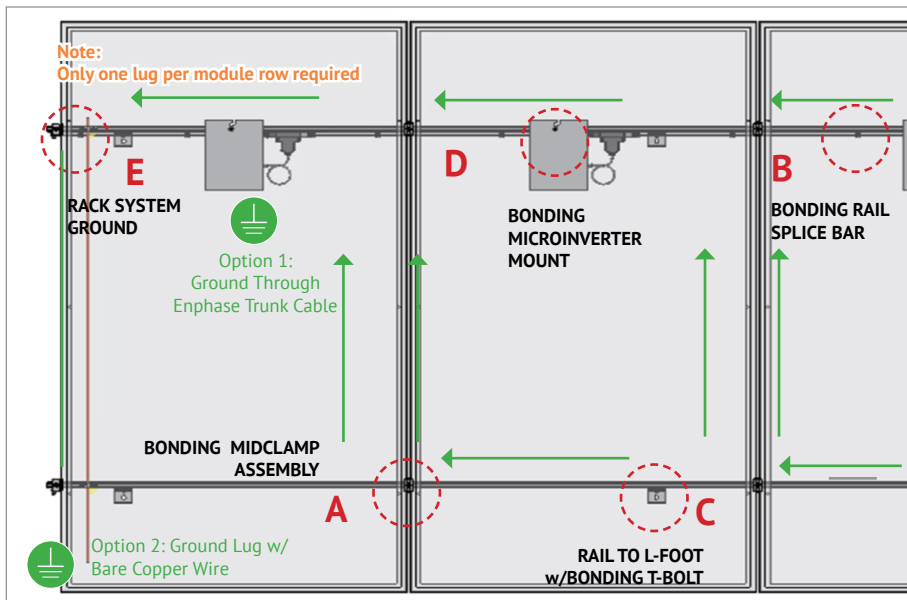

BONDING MICROINVERTER MOUNT

- 1 Hex nut with captive lock washer bonds metal microinverter flange to stainless steel T-bolt
- 2 Serrated T-bolt head penetrates rail anodization to bond T-bolt, nut, and L-foot to grounded SM rail **System ground including racking and modules may be achieved through the trunk cable of approved microinverter systems. See page 12 for details**

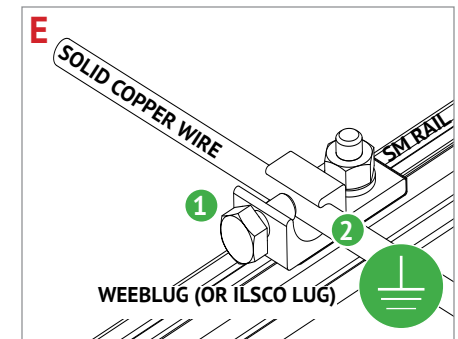

RACK SYSTEM GROUND

- 1 WEEB washer dimples pierce anodized rail to create bond between rail and lug
- 2 Solid copper wire connected to lug is routed to provide final system ground connection. **NOTE: IlSCO lug can also be used when secured to the side of the rail. See page 13 for details**

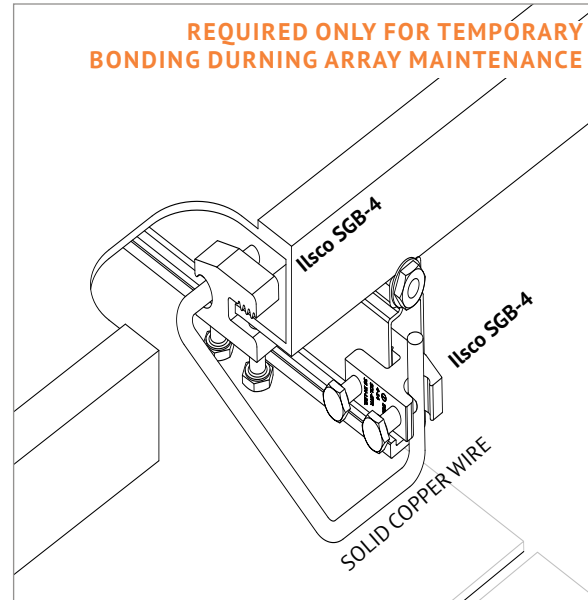
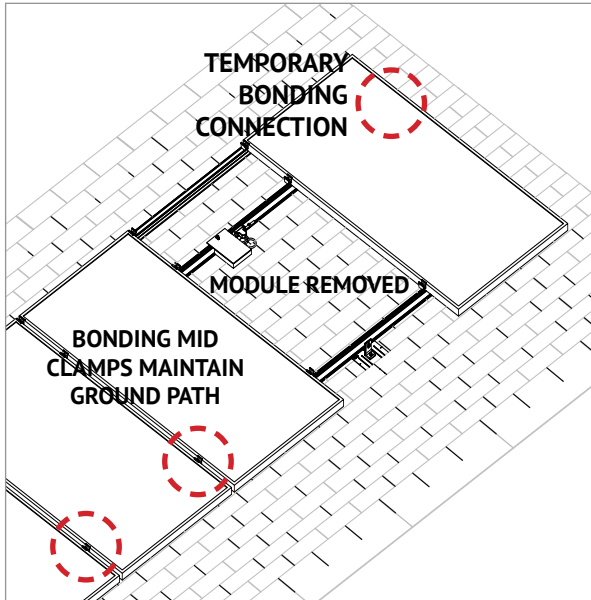

TEMPORARY BONDING CONNECTION DURING ARRAY MAINTENANCE

When removing modules for replacement or system maintenance, any module left in place that is secured with a bonding Midclamp will be properly grounded. If a module adjacent to the end module of a row is removed or if any other maintenance condition leaves a module without a bonding mid clamp, a temporary bonding connection must be installed as shown

- Attach IlSCO SGB4 to wall of rail
- Attach IlSCO SGB4 to module frame
- Install solid copper wire jumper to IlSCO lugs

ELECTRICAL CONSIDERATIONS

SOLARMOUNT is intended to be used with PV modules that have a system voltage less than or equal to that allowable by NEC. For standard system grounding a minimum 10AWG, 105°C copper grounding conductor should be used to ground a system, according to the National Electric Code (NEC). It is the installer's responsibility to check local codes, which may vary. See below for interconnection information.

INTERCONNECTION INFORMATION

There is no size limit on how many SOLARMOUNT & PV modules can be mechanically interconnected for any given configuration, provided that the installation meets the requirements of applicable building and fire codes.

GROUNDING NOTES

The installation must be conducted in accordance with the National Electric Code (NEC) and the authority having jurisdiction. Please refer to these resources in your location for required grounding lug quantities specific to your project.

The grounding / bonding components may overhang parts of the array so care must be made when walking around the array to avoid damage.

Conductor fastener torque values depend on conductor size. See product data sheets for correct torque values.

PERIODIC INSPECTION: Conduct periodic inspections for loose components, loose fasteners or any corrosion, immediately replace any affected components.

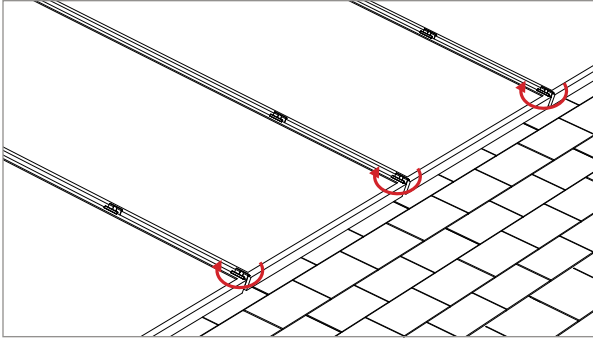

TRIM MIDCLAMPS: Ensure Trim lip is in contact with module face and verify alignment marks on T-bolts are in proper position, tighten midclamp on Trim, repeat at each gap between modules.

TORQUE VALUE: 11 ft-lbs. No anti-seize.

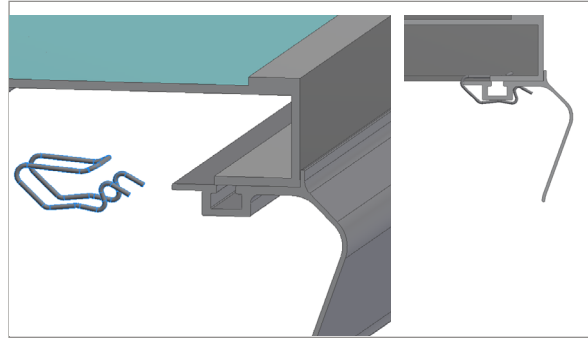

FINISH TRIM INSTALLATION. CUT EXCESS TRIM AND INSTALL TRIM CLIPS:

Attach trim to modules with at least one trim clip at each end of array and at locations where additional support is needed. Each section of trim must be attached to modules with at least one mid clamp.

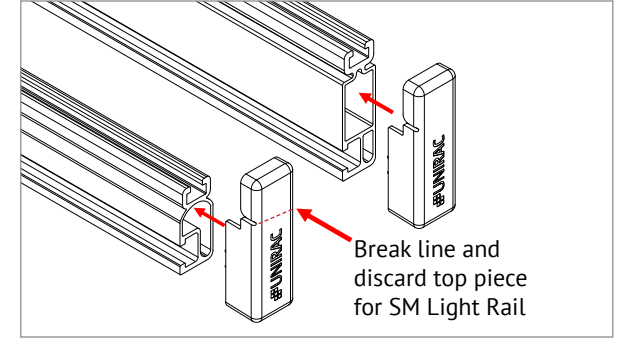

INSTALL END CAPS: End caps install as supplied on SM standard rail and SM light rail. If desired for SM light rail, the end cap may be modified as shown by hand, or by using a cutting tool.

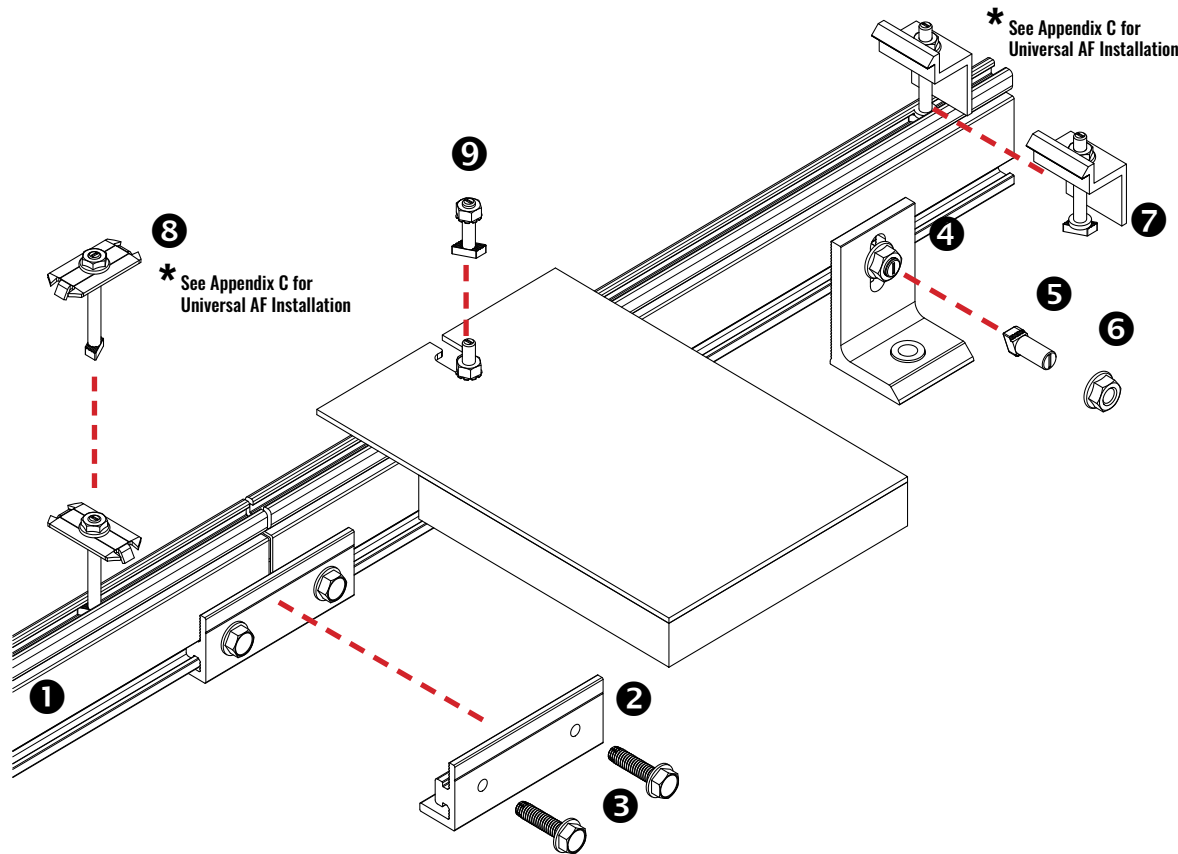

1 RAIL: Supports PV modules. Use at least two per row of modules. Aluminum extrusion, available in mill, clear anodized, or dark anodized.

2 RAIL SPLICE: Non structural splice joins, aligns, and electrically bonds rail sections into single length of rail. Forms a rigid splice joint, 4 inches long, preassembled with bonding hardware. Available in dark anodized or mill finish.

4 L-FOOT: Use to secure rails through roofing material to building structure. Refer to loading tables or U-Builder for spacing.

5 L-FOOT T-BOLT: (3/8" x 3/4" or 1") – Use one per L-foot to secure rail to L-foot. Stainless steel. Supplied with L-foot in combination with flange nut, provides electrical bond between L-foot and rail.

6 SERRATED FLANGE NUT: Use one per L-foot to secure and bond rail to Lfoot. Stainless steel. Supplied with L-foot.

7 MODULE ENDCLAMP: Provides bond from rail to endclamp. Pre-assembled aluminum clamp available in clear or dark finish. Supplied washer keeps clamp and bolt upright for ease of assembly.

8 MODULE MIDCLAMP: Pre-assembled clamp provides module to module and module to rail bond. Stainless steel clamp and T-bolt. Available in clear or dark finish.

9 MICROINVERTER MOUNTING BOLT: Pre-assembled bolt and nut attaches and bonds microinverter to rail. Washer at base keeps bolt upright for ease of assembly.

NOTE - POSITION INDICATOR: T-bolts have a slot in the hardware end corresponding to the direction of the T-Head.

NOTE - Standard Series Mid and End Clamps are single use.

Wrenches and Torque		
	Wrench Size	Recommended Torque (ft-lbs)
1/4" Hardware 7 8 9	7/16"	*10
3/8" Hardware 5	9/16"	*30
#12 Hardware 6	5/16"	10
Torques are not designed for use with wood connectors *w/Anti-Seize.		

Anti-Seize*

Stainless steel hardware can seize up, a process called galling. To significantly reduce its likelihood:

1. Apply minimal lubricant to bolts, preferably Anti-Seize commonly found at auto parts stores
2. Shade hardware prior to installation, and
3. Avoid spinning stainless nuts onto bolts at high speed.

**B SIZE
ENDCLAMP**

Module Thickness
30mm to 32mm
1.18in to 1.26in

**C SIZE
ENDCLAMP**

Module Thickness
33mm to 36mm
1.30in to 1.42in

**D SIZE
ENDCLAMP**

Module Thickness
38mm to 40mm
1.50in to 1.57in

**K SIZE
ENDCLAMP**

Module Thickness
39mm to 41mm
1.54in to 1.61in

**F SIZE
ENDCLAMP**

Module Thickness
45mm to 47mm
1.77in to 1.85in

**E SIZE
ENDCLAMP**

Module Thickness
50mm to 51mm
1.97in to 2.00in



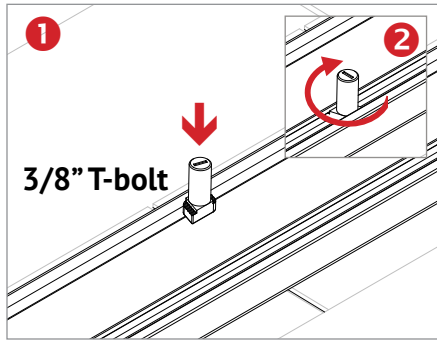

1 PLACE T-BOLT INTO RAIL & SECURE BOLT: Insert 3/8" T-bolt into rail at L-foot locations. Apply Anti-Seize to bolt. Rotate T-bolt into position.

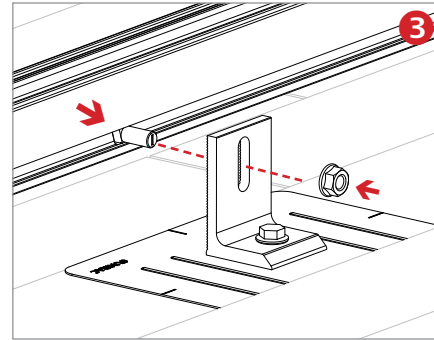

3 SECURE T-BOLT: Apply Anti-Seize to bolt. Rotate T-bolt into position.

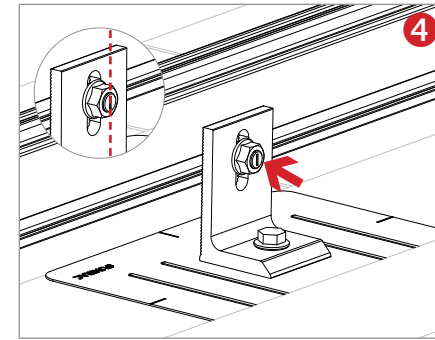

4 ALIGN POSITION INDICATOR: Hand tighten nut until rail alignment is complete. Verify that position indicator on bolt is vertical (perpendicular to rail)

TORQUE VALUE: 3/8" nut to 30 ft-lbs

ALIGN RAILS: Align one pair of rail ends to the edge of the installation area. The opposite pair of rail ends will overhang installation area. Do not Trim them off until the installation is complete. If the rails are perpendicular to the rafters, either end of the rails can be aligned, but the first module must be installed at the aligned end.

If the rails are parallel to the rafters, the aligned end of the rails must face the lower edge of the roof. Securely tighten all hardware after alignment is complete.

Mount modules to the rails as soon as possible. Large temperature changes may bow the rails within a few hours if module placement is delayed.

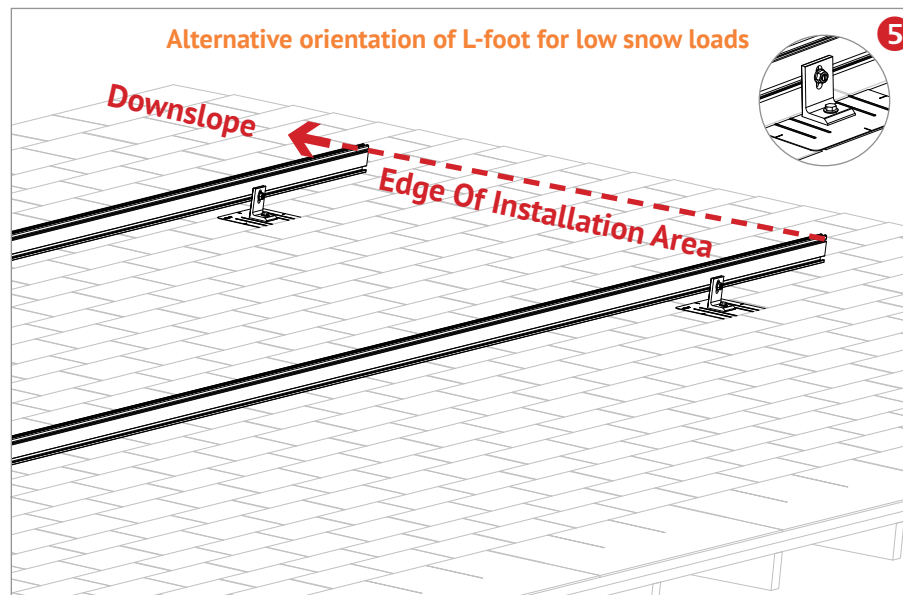

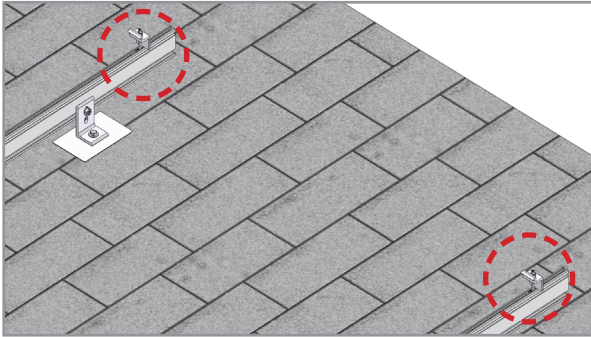

INSTALL MODULE ENDCLAMPS: The Endclamp is supplied as an assembly with a T-bolt, serrated flange nut, and washer. The washer retains the clamp at the top of the assembly. This will enable the clamp to remain upright for module installation.

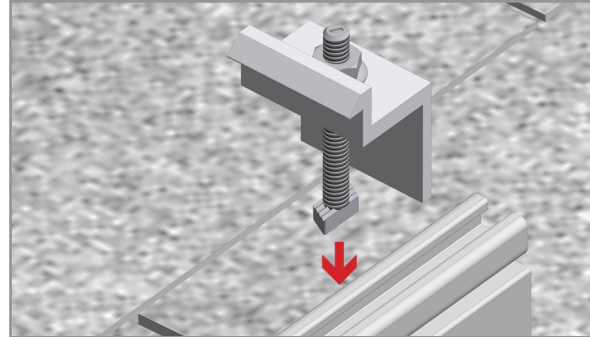

INSERT ENDCLAMP T-BOLT: Insert 1/4" T-bolt into rail.

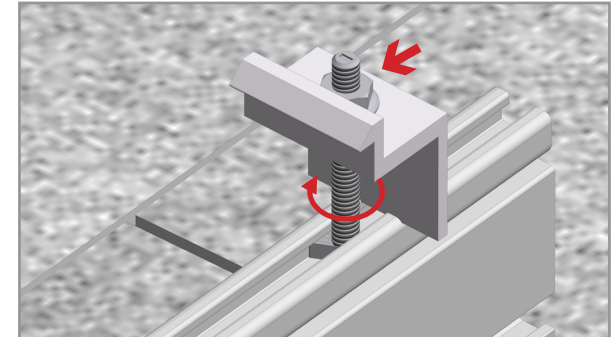

ROTATE ENDCLAMP T-BOLT: Rotate T-bolt into position. Verify that the position indicator & T-bolt shaft are angled in the correct position.

End clamps are positioned on rails prior to the first end module and installed after the last end module.

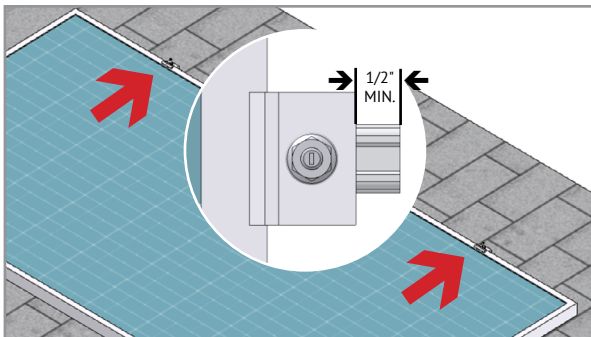

INSTALL FIRST MODULE: Install the first end module onto rails. Engage module frame with End-clamps. Verify that the position indicator & T-bolt shaft are angled in the correct position.

TORQUE VALUE: 1/4" nuts to 10 ft-lbs. with Anti Seize

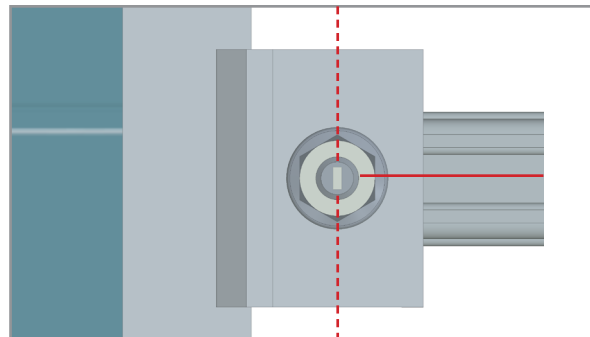

POSITION INDICATOR - SERRATED T-BOLT: Verify the T-bolt position indicator is perpendicular to the rail.

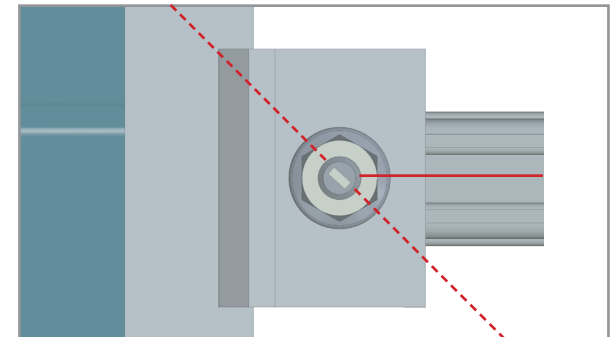

POSITION INDICATOR - NON-SERRATED T-BOLT: Verify the T-bolt position indicator is angled as shown. **FOR USE WITH MILL FINISH RAIL ONLY.**

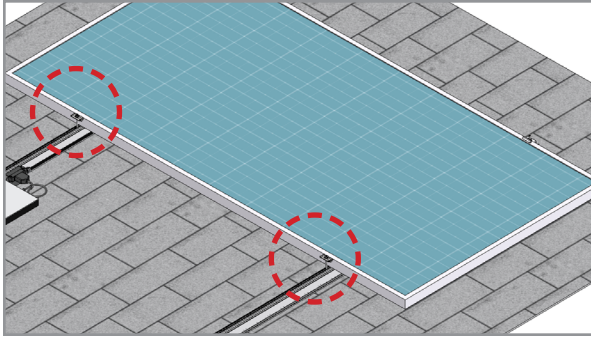

INSTALL MIDCLAMPS: Midclamp is supplied as an assembly with a T-bolt for module installation. Clamp assemblies may be positioned in rail near point of use prior to module placement.

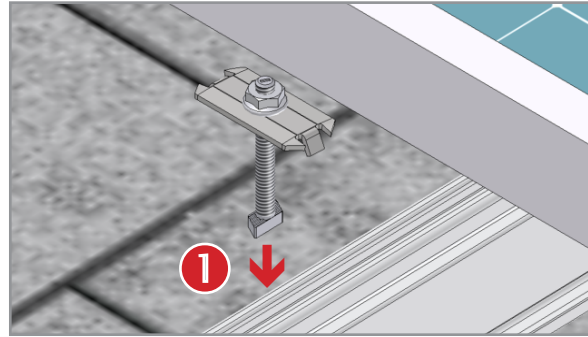

INSERT MIDCLAMP T-BOLT: Apply Anti-Seize and insert 1/4" T-bolt into rail.

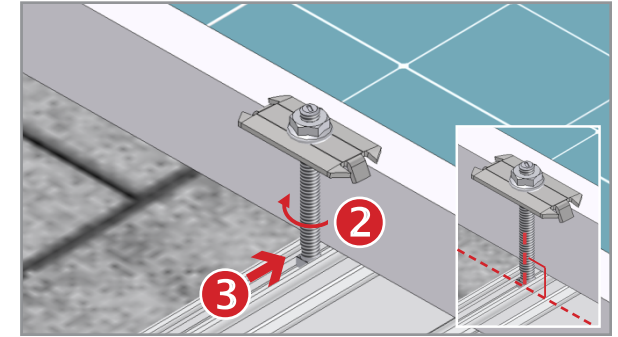

ROTATE MIDCLAMP T-BOLT: Rotate bolt into position and slide until bolt and clamp are against module frame. Do not tighten nut until next module is in position. Verify that the position indicator & T-bolt shaft are angled in the correct position.

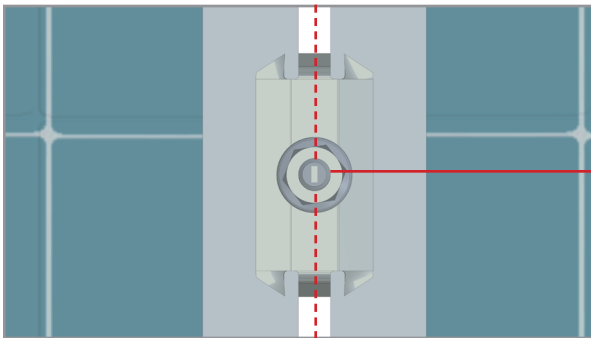

POSITION INDICATOR - SERRATED T-BOLT: Verify the T-bolt position indicator is perpendicular to the rail.

TRIM INSTALLATION INSTRUCTIONS

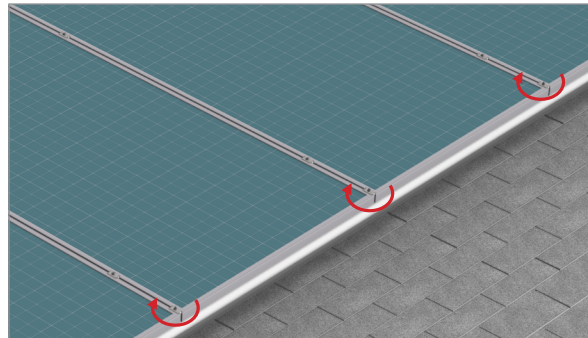

TRIM MIDCLAMPS: Ensure Trim lip is in contact with module face and verify alignment marks on T-bolts are in proper position, tighten midclamp on Trim, repeat at each gap between modules.

TORQUE VALUE: 1/4" nuts to 10 ft-lbs with Anti Seize

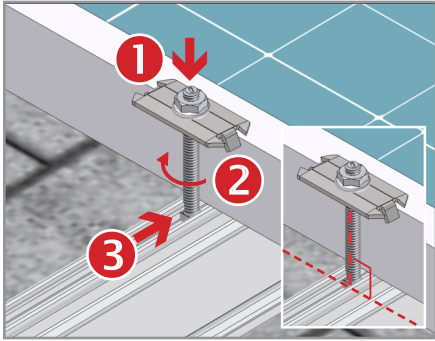

INSTALL REMAINING MID-CLAMPS: Proceed with module installation. Engage each module with previously positioned Midclamp assemblies.

NOTE: Apply Anti-Seize to each Mid Clamp prior to installation.

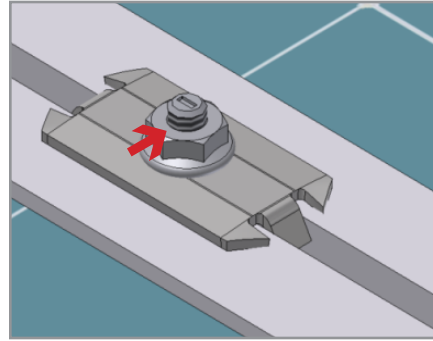

POSITION T-BOLT ALIGNMENT MARKS: Verify that the position indicator(s) & T-bolt shaft(s) are angled in the correct position.

TORQUE VALUE: 1/4" nuts to 10 ft-lbs. with Anti Seize

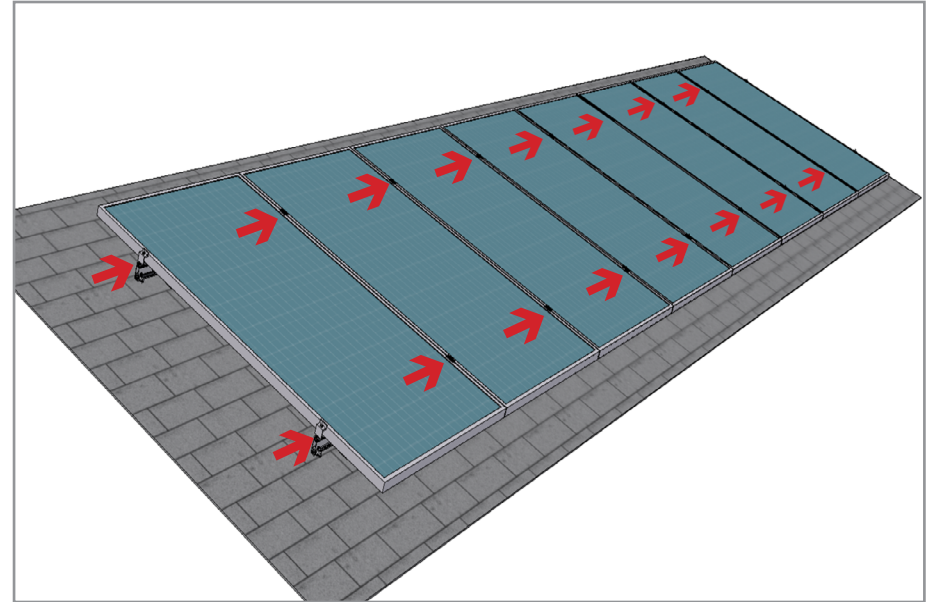

FINISH MODULE INSTALLATION: Proceed with module installation. Engage each module with the previously positioned clamp assembly:

- Install second module
- Install remaining Midclamps & modules & position alignment marks
- Install Endclamps & position alignment marks
- Cut rail to desired length

TRIM INSTALLATION INSTRUCTIONS

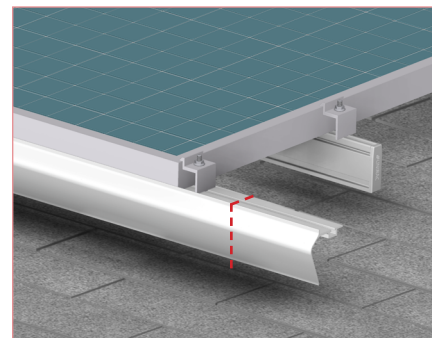

FINISH TRIM INSTALLATION, INSTALL ENDCLAMP & CUT EXCESS RAIL: Install final endclamp & Cut away excess Trim at end of array or where required for proper cantilevers. See [D&E Guide](#) or [U-Builder](#) for allowable cantilevers.

TORQUE VALUE 1/4" nuts to 10 ft-lbs with Anti Seize

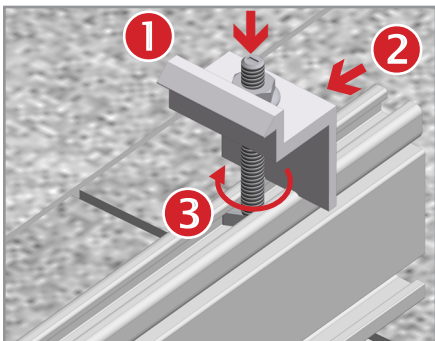

INSTALL ENDCLAMPS: Apply Anti-Seize and install final Endclamps in same manner as first Endclamps. Slide clamps against module.

TORQUE VALUE: 1/4" nuts to 10 ft-lbs. with Anti Seize.

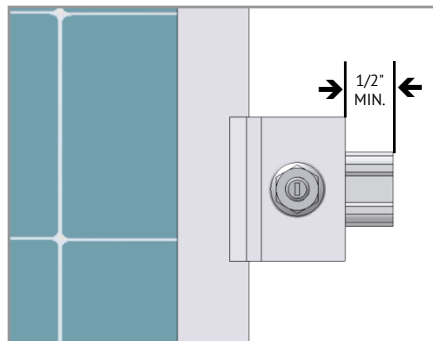

POSITION T-BOLT ALIGNMENT MARKS & CUT RAIL: Verify that the position indicator(s) & T-bolt shaft(s) are angled in the correct position. Trim off any excess rail, being careful not to cut into the roof. Allow 1/2" between the Endclamp and the end of the rail.

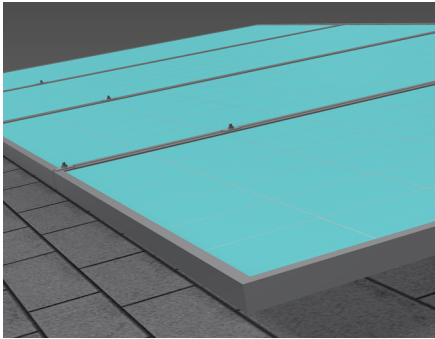

PREPARATION: At front edge of array, ensure at least 3.25 inches of space between modules and roof surface and that modules are aligned to within 3/8". Plan for Trim length so that Endclamps can be properly installed.

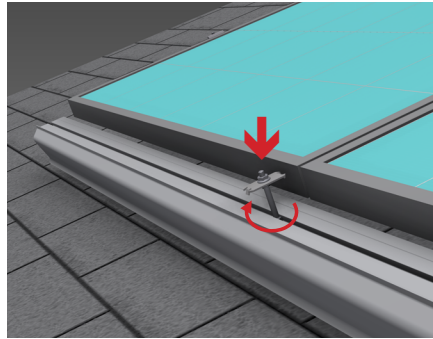

1ST MIDCLAMP: Position Trim in front of array. Insert Midclamp into the Trim slot, aligned with the gap between the 1st two modules at either end of array.

NOTE: Apply Anti-Seize to Each Mid-Clamp prior to installation

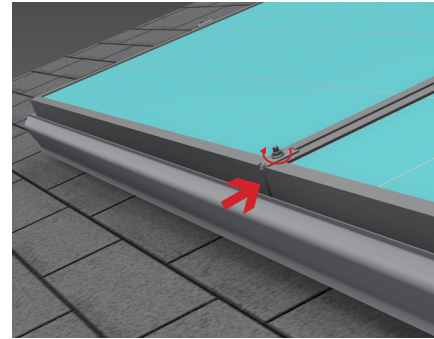

MOUNT TRIM: Position Trim beneath modules by sliding T-bolt into gap between modules and tighten. Midclamp should stay in position and support Trim. Tighten snugly enough so that Trim is held firmly in place.

TORQUE VALUE: Do not exceed specified torque value (10 ft-lbs)

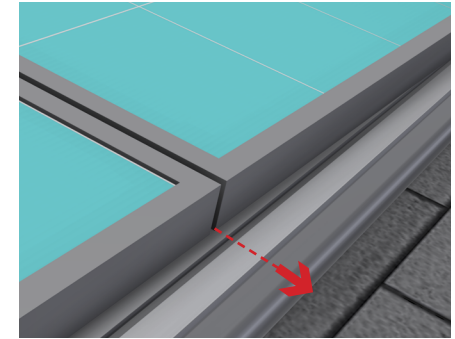

CLEAR T-BOLT SLOT: Rotate unattached end of Trim out and away from array so T-bolt slot (at next T-bolt insertion point) is clear of modules. This may require force to deflect the Trim slightly. Deflect only enough to insert T-bolt.

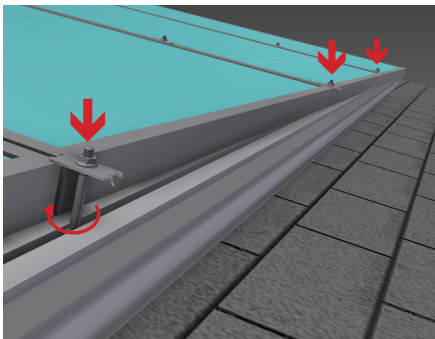

INSERT MIDCLAMPS: Insert T-bolt into slot and slide clamp (rotating Trim) into position between modules and leave loose. Continue to work down array, inserting Midclamps and positioning in gaps between modules.

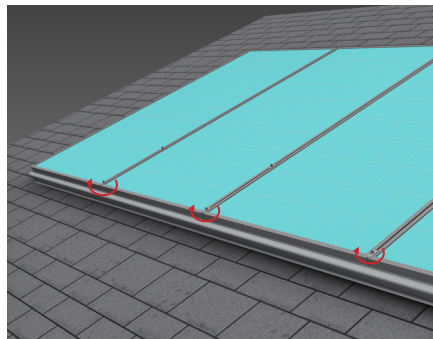

FASTEN MIDCLAMPS: Return to each inserted Midclamp. Ensuring Trim lip is in contact with module face and verifying alignment marks on T-bolts are in proper position, tighten clamp.

TORQUE VALUE
1/4" nuts to 10 ft-lbs w/ Anti Seize

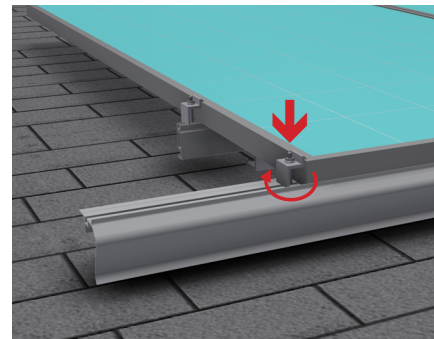

ENDCLAMPS: Install Endclamps per previous Endclamp install instructions

TORQUE VALUE
1/4" nuts to 10 ft-lbs w/ Anti Seize

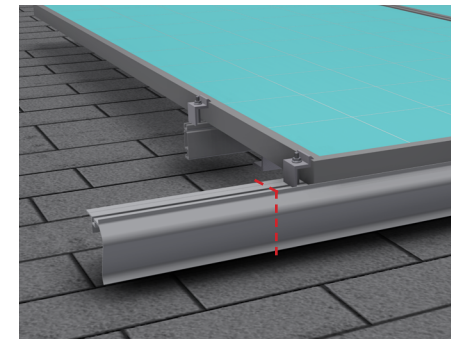

CUT EXCESS TRIM: Mark excess Trim and cut at end of array or where required for proper cantilevers.

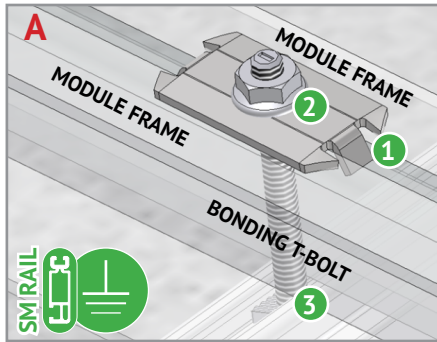

BONDING MIDCLAMP ASSEMBLY

- 1 Stainless steel Midclamp points, 2 per module, pierce module frame anodization to bond module to module through clamp.
- 2 Serrated flange nut bonds stainless steel clamp to stainless steel T-bolt
- 3 Serrated T-bolt head penetrates rail anodization to bond T-bolt, nut, clamp, and modules to grounded SM rail.

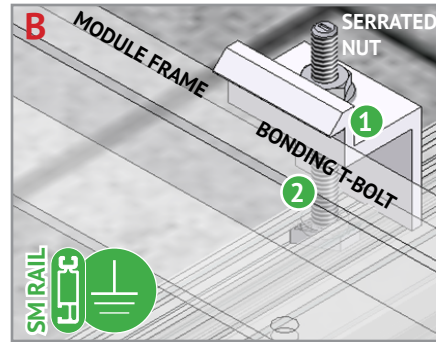

ENDCLAMP ASSEMBLY

- 1 Serrated flange nut bonds aluminum Endclamp to stainless steel T-bolt
- 2 Serrated T-bolt head penetrates rail anodization to bond T-bolt, nut, and Endclamp to grounded SM rail

Note: End clamp does not bond to module frame.

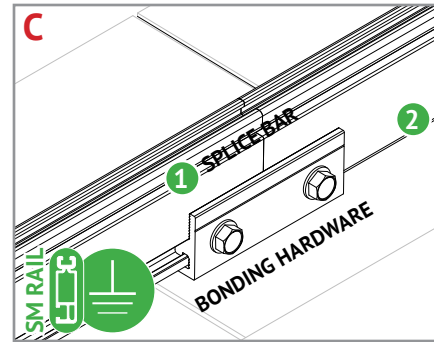

BONDING RAIL SPLICE BAR

- 1 Bonding Hardware creates bond between splice bar and each rail section
- 2 Aluminum splice bar spans across rail gap to create rail to rail bond. Rail on at least one side of splice will be grounded.

Note: Splice bar and bolted connection are non-structural. The splice bar function is rail alignment and bonding.

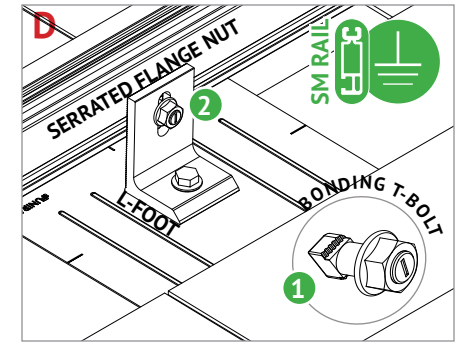

RAIL TO L-FOOT w/BONDING T-BOLT

- 1 Serrated flange nut removes L-foot anodization to bond L-Foot to stainless steel T-bolt
- 2 Serrated T-bolt head penetrates rail anodization to bond T-bolt, nut, and L-foot to grounded SM rail

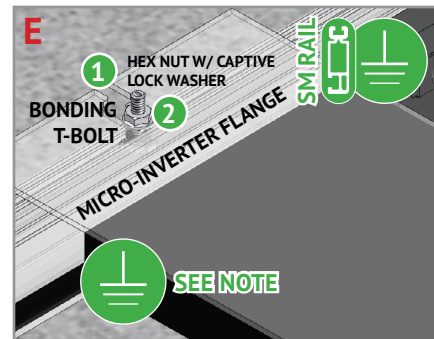
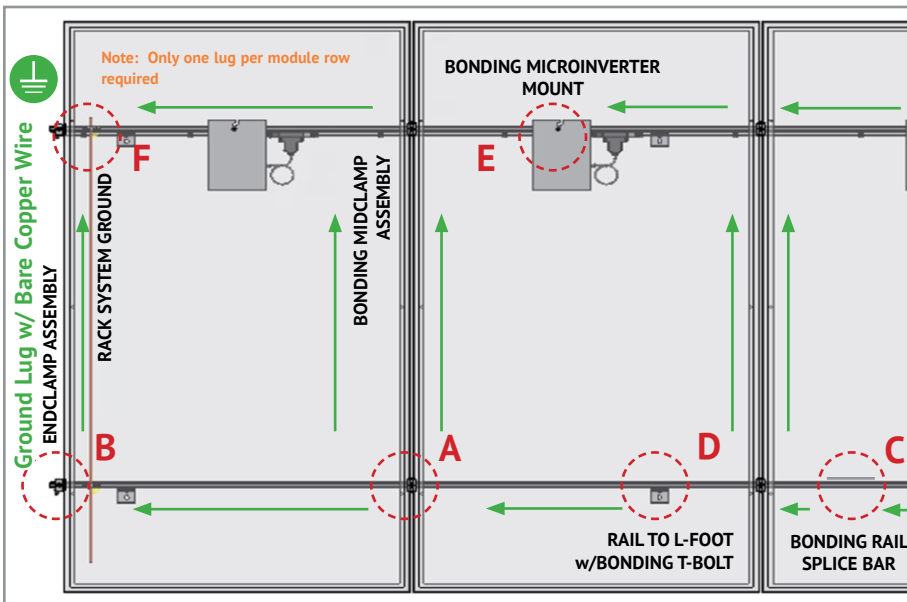

BONDING MICROINVERTER MOUNT

- 1 Hex nut with captive lock washer bonds metal microinverter flange to stainless steel T-bolt
- 2 Serrated T-bolt head penetrates rail anodization to bond T-bolt, nut, and L-foot to grounded SM rail. System ground including racking and modules may be achieved through the trunk cable of approved microinverter systems. See page 12 for details

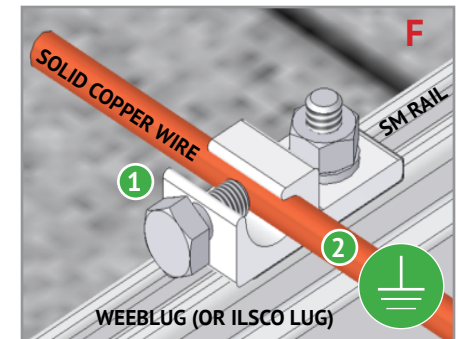

RACK SYSTEM GROUND

- 1 WEEB washer dimples pierce anodized rail to create bond between rail and lug
- 2 Solid copper wire connected to lug is routed to provide final system ground connection.

NOTE: IlSCO lug can also be used when secured to the side of the rail. See page 12 for details

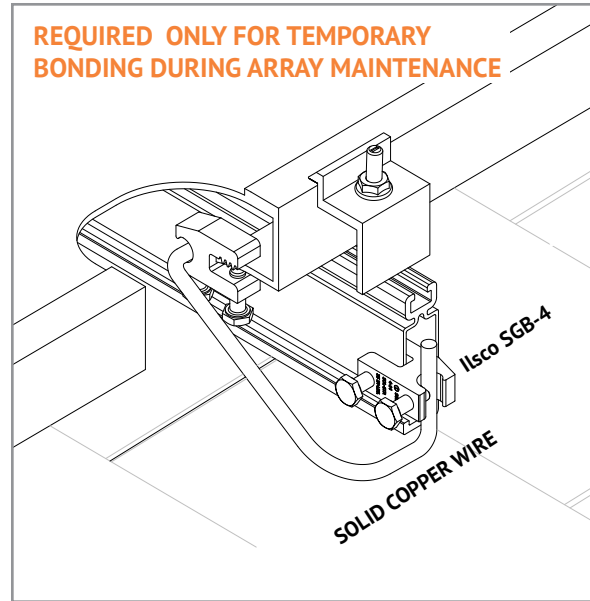
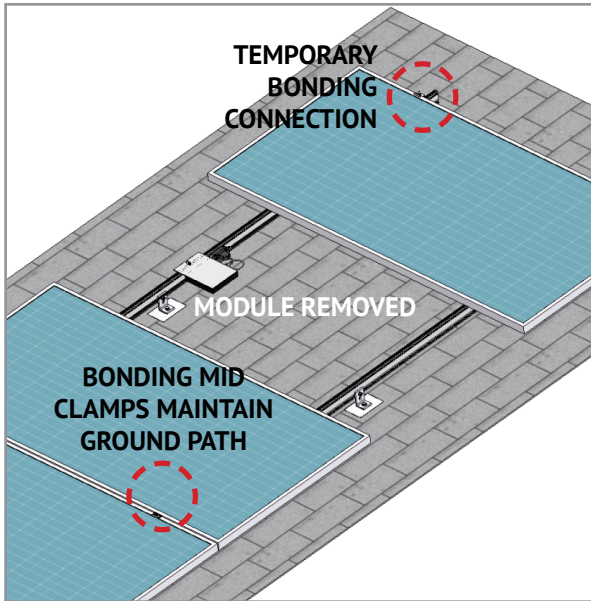

TEMPORARY BONDING CONNECTION DURING ARRAY MAINTENANCE

When removing modules for replacement or system maintenance, any module left in place that is secured with a bonding Midclamp will be properly grounded. If a module adjacent to the end module of a row is removed or if any other maintenance condition leaves a module without a bonding mid clamp, a temporary bonding connection must be installed as shown

- Attach Ilsco SGB4 to wall of rail
- Attach Ilsco SGB4 to module frame
- Install solid copper wire jumper to Ilsco lugs

ELECTRICAL CONSIDERATIONS

SOLARMOUNT is intended to be used with PV modules that have a system voltage less than or equal to that allowable by the NEC. For standard system grounding a minimum 10AWG, 105°C copper grounding conductor should be used to ground a 1000 VDC system, according to the National Electric Code (NEC). It is the installer's responsibility to check local codes, which may vary. See below for interconnection information.

INTERCONNECTION INFORMATION

There is no size limit on how many SOLARMOUNT & PV modules can be mechanically interconnected for any given configuration, provided that the installation meets the requirements of applicable building and fire codes.

GROUNDING NOTES

The installation must be conducted in accordance with the National Electric Code (NEC) and the authority having jurisdiction. Please refer to these resources in your location for required grounding lug quantities specific to your project.

The grounding / bonding components may overhang parts of the array so care must be made when walking around the array to avoid damage.

Conductor fastener torque values depend on conductor size. See product data sheets for correct torque values.

UL2703 CERTIFICATION MARKING LABEL

Unirac SOLARMOUNT is listed to UL 2703. Certification marking is embossed on all mid clamps as shown. Labels with additional information will be provided. After the racking system is fully assembled, a single label should be applied to the SOLARMOUNT rail at the edge of the array. Before applying the label, the corners of the label that do not pertain to the system being installed must be removed so that only the installed system type is showing.

Note: The sticker label should be placed such that it is visible, but not outward facing.

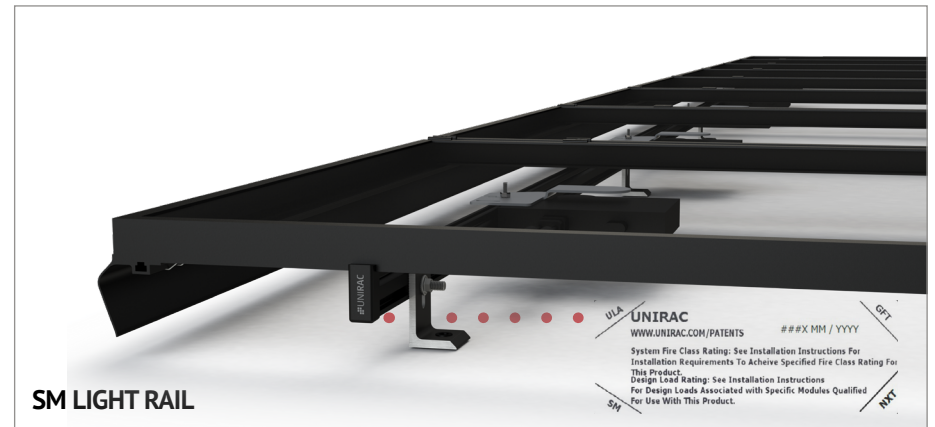
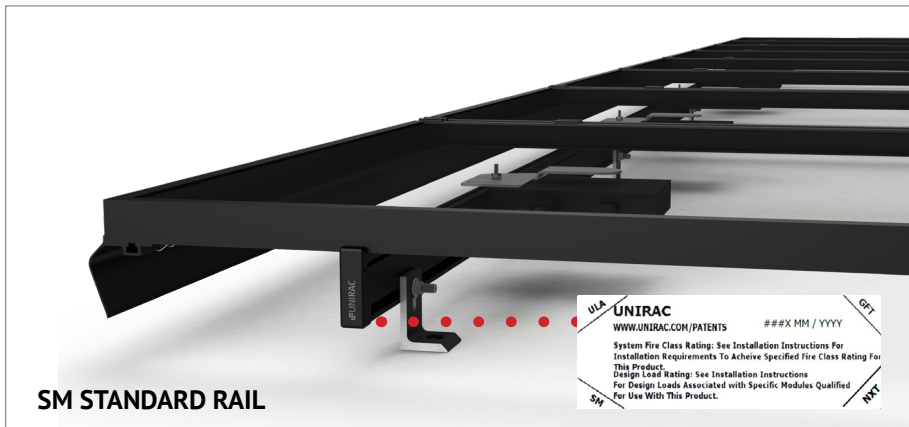
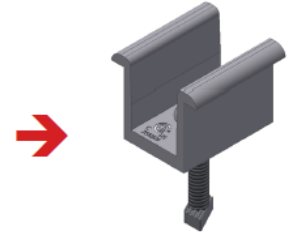

The SOLARMOUNT system has been certified and listed to the UL 2703 standard (Rack Mounting Systems and Clamping Devices for Flat-Plate Photovoltaic Modules and Panels). This standard included electrical grounding, electrical bonding, mechanical load and fire resistance testing.

In conducting these tests, specific modules are selected for their physical properties so that the certifications can be broadly applied. The following lists the specific modules that were tested and the applicability of those certifications to other modules that might come onto the market. PV modules may have a reduced mechanical load rating, independent of the SM load rating. Please consult the PV module manufacturer’s installation guide for more information.

In addition to UL 2703 certification, Unirac performs internal testing beyond the requirements of certification tests in order to establish system functional limits, allowable loads, and factors of safety. These tests include functional system tests, and destructive load testing.

MECHANICAL LOAD TEST MODULES

The modules selected for UL 2703 mechanical load testing were selected to represent the broadest range possible for modules on the market. The tests performed cover the following basic module parameters:

Frame thicknesses greater than or equal to 1.0 mm

Basic single and double wall frame profiles (some complex frame profiles could require further analysis to determine applicability)

Clear and dark anodized aluminum frames`

Tested Modules			
Module Manufacturer	Model/Series	Area [sqft]	UL2703 Certification Load Ratings
Hyundai	HiS-S325TI	21.06	Down- 113 PSF, Up - 50 PSF Down-Slope - 15 PSF
SunPower	SPR-P19-395-COM	22.20	Down- 113 PSF, Up - 50 PSF Down-Slope - 15 PSF
First Solar	FS-6xxx-P	27.12	Down- 33.9 PSF, Up - 33.9 PSF Down-Slope - 16.5 PSF
Q Cells	Q Peak Duo XL-G11.3/BFG	29.49	Down: 31.18 PSF, Up: 31.18 PSF, Down-Slope: 9.8 PSF
Trina	TSM-DEG21C.20	33.43	Down: 27.79 PSF, Up: 28.05 PSF, Down-Slope: 9.8 PSF

SYSTEM LEVEL FIRE CLASSIFICATION

The system fire class rating requires installation in the manner specified in the SOLARMOUNT Installation Guide. SOLARMOUNT has been classified to the system level fire portion of UL2703. SOLARMOUNT has achieved system level performance for steep sloped roofs and low sloped roofs. See table below for definition of steep sloped and low sloped roofs. The system is to be mounted over fire resistant roof covering rated for the application. There is no required minimum or maximum height limitation above the roof deck to maintain the system fire rating for SOLARMOUNT. Module Types, System Level Fire Ratings, & Mitigation Requirements are listed below:

ROOF TYPE	Rail Type	Module Fire Type	System Level Fire Rating	Rail Direction	Module Orientation	Mitigation Required
Steep Slope - roof pitches \geq 2 in/ft	Standard & HD Rail	1, 2, 3 with metal frame, 10 with metal frame, 19, 22, 25, 29, 30 & 38	Class A	Parallel OR Perpendicular to Ridge	Landscape OR Portrait	None Required
	Light Rail	1, 2, 29, 30 & 38				None Required
	Standard, Light, & HD Rail	4 & 5				Trim installation per Solar Mount Installation Guide
Low Slope - roof pitches < 2in/ft	Standard, Light, & HD Rail	Type 1, 2, 29, 30 & 38	Class A	Parallel OR Perpendicular to Ridge	Landscape OR Portrait	None Required

This racking system may be used to ground and/or mount a PV module complying with UL1703 or UL61730 only when the specific module has been evaluated for grounding and/or mounting in compliance with the included instructions.

Electrical Bonding and Grounding Test Modules

The list below is not exhaustive of compliant modules but shows those that have been evaluated and found to be electrically compatible with the SOLARMOUNT system.

Manufacture	Module Model / Series	Manufacture	Module Model / Series	Manufacture	Module Model / Series
Aionrise	AION60G1, AION72G1		BVM6610	Centrosolar America	C-Series & E-Series
Aleo	P-Series & S-Series	Boviet Solar	BVM6610M-xxxS-H-HC-BF BVM6612 BVM6612M-xxxS-H-HC-BF-DG BVM7612M-H-HC-BF-DG	CertainTeed	CT2xxMxx-01, CT2xxPxx-01, CTxxMxx-01 CTxxxPxx-01, CTxxxMxx-02, CTxxxMxx-03 CTxxxMxx-04, CTxxxHC11-04 CTM10400HC11-08, CTM10400HC11-09 CTM10400HC11-06, CTxxxHC11-06 CTTCxxxHC12-08
Aptos Solar	DNA-108-(MF/BF)10-xxxW DNA-120-(MF/BF)10-xxxW DNA-120-(MF/BF)23 DNA-120-(MF/BF)26 DNA-120-MF10 DNA-144-(MF/BF)23 DNA-144-(MF/BF)26 DNA-144-BF10-xxxW-DG	BYD	P6K & MHK-36 Series	Eco Solargy	Orion 1000 & Apollo 1000
Astronergy	ASM6612P Series CHSM6612 M, M/HV CHSM6612P/HV Series CHSM6612P Series CHSM66M(DG)/F-BH (fire type 29 only) CHSM72M(DG)/F-BH CHSM72M-HC	Canadian Solar	CS1(H/K/U/Y)-MS CS3K-(MB/MB-AG/MS/P/P HE/PB-AG) CS3L-(MS/P), CS3N-MS CS3U-(MB/MB-AG/MS/P/P HE/PB/PB-AG) CS3W-(MS/MB-AG/P/P-PB-AG) CS3Y-MB-AG CS5A-M CS6.1-54TM-H CS6.1-60TM-H CS6.1-72TB-H CS6.2-66TB-xxxH CS6K-(M/MS/MS AllBlack/P/P HE) CS6P-(M/P) CS6R-MS CS6R-xxxMS-HL CS6U-(M/P/P HE) CS6W-(MS/MB-AG) CS6W-xxx-TB-AG CS6X-P, CSX-P CS7L-MB-AG CS7L-TB-AG CS7N-xxxMB-AG CS7N-xxx MS CS7N-xxxTB-AG ELPS CS6(A/P)-MM	EMMVEE	ExxxHCBG144-T ExxxHCBT144-T ExxxH CM120-B ExxxM72-B ExxxP72-B Titanium Clear
Auxin	AXN10Mxxx AXN6M610T AXN6M612T AXN6P610T AXN6P612T AXNG1M SERIES			Energy America	ZLK-xxx
Axitec	AC-xxx(M/P)/60S, AC-xxx(M/P)/72S AC-xxxMH/120(S/V/SB/VB) AC-xxxMH/144(S/V/SB/VB) AC-xxxP/156-60S AC-xxxTGB/144TS			ET Solar	ET AC Module, ET Module ET-M772BH520-550WW/WB ET-M772BHxxxTW/TB
Bluesun Solar	HEX5 BSMxxxM10-54HPH BSMxxxM10-72HBD			First Solar	FS-6XXX(A) FS-6XXX(A)-P, FS-6XXX(A)-P-I
Boviet	BVM6610M-xxxS-H-HC			Flextronics	FXS-xxxBB
				Freedom Forever	FF-MP-BBB-xxx, FF-MP1-BBB-xxx
				FreeVolt	PVGraf
				GCL	GCL-P6 & GCL-M6 Series
				Hansol	TD-AN3, TD-AN4 UB-AN1, UD-AN1
				Hanwha SolarOne	HSL 60

- Unless otherwise noted, all modules listed above include all wattages and specific models within that series. Variable wattages are represented as "xxx"
- Items in parenthesis are those that may or may not be present in a compatible module's model ID
- Slashes "/" between one or more items indicates that either of those items may be the one that is present in a module's model ID
- The frame profile must not have any feature that might interfere with the bonding devices that are integrated into the racking system
- Use with a maximum over current protection device OCPD of 30A
- **Listed models can be used to achieve a Class A fire system rating for steep slope and low slope applications. See page 33**

Electrical Bonding and Grounding Test Modules

The list below is not exhaustive of compliant modules but shows those that have been evaluated and found to be electrically compatible with the SOLARMOUNT system.

Manufacture	Module Model / Series	Manufacture	Module Model / Series	Manufacture	Module Model / Series		
Heliene	132HC M10 SL Monofacial Module	Illuminate USA	IL5-72HBD-xxx M	Jinko (Cont.)	JKMxxxM-72HL4-TV JKMxxxM-72HLM-TV JKMxxxM-72HL-V JKMxxxM-7RL3-TV JKMxxxM-7RL3-V JKMxxxN-54HL4-B JKMxxxN-72HL4-BDV JKMxxxN-72HL4-BDX JKMxxxN-72HL4-TV		
	144HC M10 SL Bifacial		IL8-66HGD-xxx M				
144HC M6	Imperial Star	ISM7-SHDD108-400/M					
156HC M10 SL Bifacial		ITEK	iT-SE Series				
36M, 36P 60M, 60P, 72M & 72P Series	Japan Solar	JPS-60 & JPS-72 Series					
HT-SAAE	HT60-156M(V)-C	JA Solar	JAM6(K)-60/xxx, JAP6(k)-72-xxx/4BB			Kyocera	KD-F & KU Series
	HT60-156M-C		JAP72S##-xxx/**				
	HT72-156(M/P)		JAP6(k)-60-xxx/4BB, JAP60S##-xxx/**			LA Solar	LSxxxBF LSxxxBL LSxxxBL (410 watt) LSxxxHC(166) LSxxxHC (430-450 watt range) LSxxxHC, BLA Model
	HT72-156M(PD)-BF		JAM6(k)-72-xxx/**, JAM72S##-xxx/**				
	HT72-156M(PDV)-BF		JAM6(k)-60-xxx/**, JAM60S##-xxx/**				
	HT72-156P(V)-C		i. ##: 01, 02, 03, 09, 10				
	HT72-156P-C		ii. **: SC, PR, BP, HiT, IB, MW, MR				
	HT72-166M		** = Backsheet, ## Cell technology				
HT72-18X	JAM54D41-xxx/MB						
Hyperion Solar	HY-DH108P8(B), HY-DH108N8B		JAM54S30 xxx/MR	LG Electronics	LGxxx(E1C/E1K/N1C/N1K/N2T/N2W/S1C/S2W/Q1C/Q1K)-A5 LGxxx(A1C/M1C/M1K/N1C/N1K/Q1C/Q1K/QAC/QAK)-A6, LGxxxN2W-B3 LGxxxN2T-B5 LGxxxN1K-B6 LGxxx(N1C/N1K/N2T/N2W)-E6 LGxxx(N1C/N1K/N2W/S1C/S2W)-G4 LGxxxN2T-J5, LGxxx(N1K/N1W/N2T/N2W)-L5 LGxxx(M1C/N1C/Q1C/Q1K)-N5 LGxxx(N1C/N1K/N2W/Q1C/Q1K)-V5 LGxxxN3K-V6		
	HY-DH144P8, HY-DH156N8, HY-DH156P8	JAM54S31 xxx/MR					
Hyundai	KG, MG, RW, TG, RI, RG, TI, KI, HI Series	JAM66D45 LB	Jinko			JKM & JKMS Series JKMxxxM-6RL3-B JKMxxxM-72HBL-V JKMxxxM-72HL4-(T)V	
	HiA-SxxxHG	JAM72D10 xxx/MB					
	HiD-SxxxRG(BK)	JAM72D30MB					
	HiN-SxxxXG(BK)	JAM72D40 xxx/MB					
	HiN-TxxxNF(BK)	JAM72S30 /MR					
	HiN-TxxxNI	JAM78D10MB					
	HiN-TxxxNJ	JAP6 60-xxx					
	HiN-TxxxOJ	Jinko					JKM & JKMS Series JKMxxxM-6RL3-B JKMxxxM-72HBL-V JKMxxxM-72HL4-(T)V
	HiS-S400PI						
	HiS-SxxxGI	Jinko		JKM & JKMS Series JKMxxxM-6RL3-B JKMxxxM-72HBL-V JKMxxxM-72HL4-(T)V			
	HiS-SxxxOJ						
	HiS-SxxxXG(BK)						
	HiS-SxxxYH(BK)						
	HiS-TxxxNF(BK)						
	HiS-TxxxNJ						

- Unless otherwise noted, all modules listed above include all wattages and specific models within that series. Variable wattages are represented as "xxx"
- Items in parenthesis are those that may or may not be present in a compatible module's model ID
- Slashes "/" between one or more items indicates that either of those items may be the one that is present in a module's model ID
- The frame profile must not have any feature that might interfere with the bonding devices that are integrated into the racking system
- Use with a maximum over current protection device OCPD of 30A
- **Listed models can be used to achieve a Class A fire system rating for steep slope and low slope applications. See page 33**

Electrical Bonding and Grounding Test Modules

The list below is not exhaustive of compliant modules but shows those that have been evaluated and found to be electrically compatible with the SOLARMOUNT system.

Manufacture	Module Model / Series
LONGi	LR4-60(HPB/HPH)
	LR4-72(HPH)
	LR4-72HBD xxxM
	LR5-54HABB-xxx M
	LR5-54-HPB-xxx M
	LR5-54HTB xxxM
	LR5-72HBD xxx M
	LR6-60
	LR6-60(BK/HPB/HPH/HV/PB/PE/PH)
	LR6-72
	LR6-72(BK/HV/PB/PE/PH)
	LR7-72HGD-xxx M
	LR8-54HGBB
	LR8-66HGD-xxx M
	RealBlack LR4-60HPB
RealBlack LR6-60HPB	
Maxeon	SPR-MAX3-xxx-COM
	SPR-MAX3-xxx-R
	SPR-MAX3-xxx-BLK-R
	SPR-MAX6-xxx
	SPR-MAX6-xxx-BLK
Meyer Burger	Meyer Burger Black
	Meyer Burger White
	Meyer Burger Glass
Mission Solar Energy	MSE Mono, MSE Perc
	MSExxx(SR8T/SR8K/SR9S/SX5T)
	MSExxx(SX5K/SX6W)
	MSExxxHT0B
	MSExxxSX6Z
MSExxxSX9R	

Manufacture	Module Model / Series
Mission Solar Energy (Cont.)	MSH10-xxxHN4G
	MSH10-xxxHT4T
	MSI10-xxxHN4G
Mitrex	MSI10-xxxHT4G
	MSI10-xxxHT4T
	MSN10xxxHT4T
	MSX10-xxxHN0B
	Mxxx-L3H, Mxxx-I3H
Mitsubishi	MJE & MLE Series
mSolar	108BB HC Series (TXI10-xxx108BB)
	144BB HC Series (TXS6-xxx144BB)
Neo Solar Power Co.	D6M Series
NE Solar	NESE xxx-60MH-M6
	NESE xxx 66MHB-G12
	NESE xxx-72MHB-M10
	NESE xxx 72MHT-M10
	NESE xxx 72THB-M10
NESE xxx 72MHB-M10	
Panasonic	VBHNxxxSA06/SA06B/SA11/SA11B
	VBHNxxxSA15/SA15B/SA16/SA16B,
	VBHNxxxKA, VBHNxxxKA03/04,
	VBHNxxxSA17/SA17G/SA17E/SA18/SA18E,
	VBHNxxxZA01/ZA02/ZA03/VBHNxxxZA04
Peimar	EVPVxxx
	EVPVxxx(H/K/PK/HK/HK2)
Peimar	SGxxxM (FB/BF)
	SMxxxM

Manufacture	Module Model / Series
Philadelphia Solar	PS-M108(HCBF)-400W (30 & 35mm frames)
	PS-M144(HCBF)-xxxW
Phono Solar	PS-MNB108(HCBF)-xxxW
	PS-MNB144(HCBF)-xxxW
	PS-MNB156(HCBF)-xxxW
	PSxxxM1-20/U
	PSxxxM1H-20/U
	PSxxxM1-20UH
	PSxxxM1H-20UH
	PSxxxM4(H)-24/TH
	PSxxxM1-20/UH
	PSxxxM1H-20/UH
Prism Solar	PSxxxM-24/T
	PSxxxMH-24/T
	PSxxxM-24/TH
	PSxxxMH-24/TH
Q Cells	P72 Series, P72X-xxx
	Peak G5(SC) , G6(+)(SC)(AC), G7, G8(+),
	Peak L-G5, L-G6, L-G7, L-G8(BFF)
	Plus, Pro, Peak, G3, G4,
	Plus, Pro, Peak L-G2, L-G4, L-G5
	Q.PEAK DUO(BLK)-G6+
	Q.PEAK DUO (BLK)-G7
	Q.PEAK DUO (BLK) G8(+)
	Q.PEAK DUO (BLK) ML-G10(a)(+)
	Q.PEAK DUO (BLK) ML-G9(+)
Q.PEAK DUO BLK G10(+)	

- Unless otherwise noted, all modules listed above include all wattages and specific models within that series. Variable wattages are represented as "xxx"
- Items in parenthesis are those that may or may not be present in a compatible module's model ID
- Slashes "/" between one or more items indicates that either of those items may be the one that is present in a module's model ID
- The frame profile must not have any feature that might interfere with the bonding devices that are integrated into the racking system
- Use with a maximum over current protection device OCPD of 30A
- **Listed models can be used to achieve a Class A fire system rating for steep slope and low slope applications. See page 33**

Electrical Bonding and Grounding Test Modules

The list below is not exhaustive of compliant modules but shows those that have been evaluated and found to be electrically compatible with the SOLARMOUNT system.

Manufacture	Module Model / Series	Manufacture	Module Model / Series	Manufacture	Module Model / Series	
Q Cells (Cont.)	Q.PEAK DUO BLK G10+ /AC	Q Cells (Cont.)	Q.TRON BLK M-G2+ SERIES	Seraphim	SEG-(6PA/6PB/6MA/6MA-HV/6MB/E01/E11)	
	Q.PEAK DUO BLK-G6+/TS		Q.TRON M-G2+ SERIES		SRP-(6QA/6QB)	
	Q.PEAK DUO BLK ML-G10.B+	Q.TRON XL-G2.3/BFG	SRP-320-375-BMB-HV			
	Q.PEAK DUO BLK ML-G10.C+	Q.PEAK DUO BLK ML-G10.XY+/AC (where "X" = any letter between A to W, where "Y" = any number between 1 to 9.)	SRP-390-405-BMD-HV			
	Q.PEAK DUO BLK ML-G10+ / t		SRP-390-450-BMA-HV			
	Q.PEAK DUO BLK ML-G10+ / TS	REC	SRP-xxx-6MB-HV			
	Q.PEAK DUO-G10+		RECxxxAA (BLK/Pure/Pure-R/ Pure-RX/ Pure 2/ Pro M)		SRP-xxx-BMC-HV	
	Q.PEAK DUO L-(G7/G7.1/G7.2/G7.3/G7.7)		RECxxxNP (N-PEAK)		SRP-xxx-BMZ-HV	
	Q.PEAK DUO L-(G8/G8.1/G8.2/G8.3)		RECxxxNP2 (Black)		SRP-xxx-BTA-BG	
	Q.PEAK DUO L-G6.3 / BFG		RECxxxNP3 Black		SRP-xxx-BTB-BG	
	Q.PEAK DUO L-G8.3 (BFF/BFG/BGT)		RECxxxPE, RECxxxPE72		SRP-xxx-BTC-BG	
	Q.PEAK DUO ML-G12S.3 / BFG		RECxxxTP, RECxxxTP72		SRP-xxx-BTD-BG	
	Q.PEAK DUO ML-G12S.d / BFG		RECxxxTP2(M/BLK2)		SRP-xxx-BTE-BG	
	Q.PEAK DUO XL-(G10/G10.2/G10.3/G10.c/ G10.d)		RECxxxTP2S(M)72		Sharp	NU-SA & NU-SC Series
	Q.PEAK DUO XL-(G11.2/G11.3)		RECxxxTP3M (Black)			Silfab
	Q.PEAK DUO XL-(G9/G9.2/G9.3)	RECxxxTP4 (Black)	SIL-xxx(BG/BK/BL/HC/HC+/HL/HM/HN/ML/ NL/NT/NX/NU)			
	Q.PEAK DUO XL-G10.3/BFG	Renesola	All 60-cell modules	SIL-xxx QD, SIL-xxx QM		
	Q.PEAK DUO XL-G10.d/BFG		RS6-xxxNBG-E3	SIL-xxx XM, SIL-xxx XM+		
	Q.PEAK DUO XL-G11.3/BFG	Risen	RSM Series, RSM110-8-xxxBMDG	Silfab	SIL-xxx XL	
	Q.PEAK DUO G10.C1+ AC		SEG Solar	SEG-xxx-BMD-HV	Sirius	ELNSM54M-HC-BF Series
Q.PEAK DUO XL-G11S.3 / BFG	SEG-xxx-BMD-TB, SEG-xxx-BMB-TB	ELNSM54M-HC Series				
Q.PEAK DUO XL-G9.3/BFG	SEG-xxx-BMA-HV, SEG-xxx-BMA-TB	ELNSM72M-HC Series				
Q.PEAK DUO XL-G9.3/BFG	SEG-xxx-BMA-BG	Solar4America		S4Axxx-108MH10BB, S4Axxx-72MH5BB		
Q.TRON BLK M-G2+	SEG-xxx-BMB-HV, SEG-xxx-BMA-BG			S4Axxx-144MH10xxx, S4Axxx-144TH10xxx		
Q.TRON BLK M-G2+ AC	SEG-xxx-BMB-BG, SEG-xxx-BTA-BG			S4Axxx-144TH16xxx, S4Axxx-108MH10xxx		
Q.TRON BLK M-G2.C+	SEG-xxx-BTB-BG, SEG-xxx-BMD-BG			S4Axxx-108TH10xxx		
Q.TRON BLK M-G2.F+	S-Energy	SN72 & SN60 Series	SolarEver USA	SE-166*83-xxxM-120N		
Q.TRON BLK M-G2.F1+/AC		SL45-60BG/BHI		SE-182*105-xxxM-96-BD		
Q.TRON BLK M-G2.H+	SL45-60MBI-xxxZ	SE-182*91-xxxM-108N				

- Unless otherwise noted, all modules listed above include all wattages and specific models within that series. Variable wattages are represented as "xxx"
- Items in parenthesis are those that may or may not be present in a compatible module's model ID
- Slashes "/" between one or more items indicates that either of those items may be the one that is present in a module's model ID
- The frame profile must not have any feature that might interfere with the bonding devices that are integrated into the racking system
- Use with a maximum over current protection device OCPD of 30A
- **Listed models can be used to achieve a Class A fire system rating for steep slope and low slope applications. See page 33**

Electrical Bonding and Grounding Test Modules

The list below is not exhaustive of compliant modules but shows those that have been evaluated and found to be electrically compatible with the SOLARMOUNT system.

Manufacture	Module Model / Series	Manufacture	Module Model / Series	Manufacture	Module Model / Series
Solaria	PowerXT-xxxR-(AC/PD/BD) PowerXT-xxxC-PD PowerXT-xxxR-PM (AC) PowerX-400R	Tesla	SC, SC B, SC B1, SC B2, TxxxS, TxxxH	Vikram Solar	Eldora, Somera, Ultima PREXOS VSMDHT.60.AAA.05 PREXOS VSMDHT.72.AAA.05 Paradea VSMDH.72.AAA.05
Solartech	STU HJT, STU PERC & Quantum PERC	Thornova	TS-BG54 TS-BG72 TS-BBT54(xxx) TS-BGT72(xxx)	Vina	VNS-72M1-5-xxxW-1.5, VNS-72M3-5-xxxW-1.5, VNS-144M1-5-xxxW-1.5, VNS-144M3-5-xxxW-1.5, VNS-120M3-5-xxxW-1.0
SolarWorld	Sunmodule Protect, Sunmodule Plus/Pro	Trina	DE09C.07 DEG15HC.20(II), DEG15MC.20(II) DEG15VC.20(II), DE18M(II), DEG18MC.20(II) DE19, DEG19C.20 PA05, PD05, DD05, DD06, DE06, DE09.05 PD14, PE14, DD14, DE14, DE15, DE15V(II) TSM-DE09.08, TSM-DE09C.07, TSM-DE09.05 TSM-DEG21C.20, TSM-NE09RC.05 TSM-DE06X.05(II) TSM-NE09RH.05 TSM-NE19RC TSM-NEG19RC.20 TSM-NEG21C.20	VSUN	VSUN4xx-144BMH VSUN4xx-144BMH-DG VSUN5xx-144BMH-DG VSUNxxx-108BMH VSUNxxx-108M-BB VSUNxxx-108MH VSUNxxx-120BMH VSUNxxx-120M-BB VSUNxxx-132BMH VSUNxxx-144BMH, VSUNxxx-144M-BB VSUNxxx-144M-BW VSUNxxx-144MH VSUNxxx-60M-BB VSUNxxx-72MH VSUNxxxN-108BMH-BB VSUNxxxN-108BMH-BB (SoftPaw) VSUNxxxN-120BMH-BB (SoftPaw) VSUNxxxN-144BMH, VSUNxxxN-144MH
Sonali	SS-M-360 to 390 Series SS-M-390 to 400 Series SS-M-440 to 460 Series SS-M-430 to 460 BiFacial Series	TSMC	TS-150C2 CIGSw	Waaree	Ahnay Series Bi-33 Arka Series WSMDi
Sun Edison	F-Series, R-Series	Universal Solar	UNI4xx-144BMH-DG UNI5xx-144BMH-DG UNIxxx-108M-BB UNIxxx-120M-BB UNIxxx-120MH	Winaico	WST & WSP Series
Suniva	MV Series & Optimus Series (35mm)	Upsolar	UP-MxxxP, UP-MxxxM(-B)		
Sunmac Solar	M754SH-BB Series	URECO	D7Kxxx(H7A/H8A), D7Mxxx(H7A/H8A) F6MxxxE7G-BB FAKxxx(C8G/E8G), FAMxxxE7G-BB FAMxxxE8G(-BB), FBKxxxM8G FBMxxxM7G-BB FBMxxxMFG-BB		
SunPower	AC, X-Series, E-Series & P-Series SPR E20 435 COM (G4 Frame) Axxx-BLK-G-AC, SPR-Mxxx-H-AC SPR-Mxxx-H-AC, SPR-Mxxx-BLK-H-AC				
SunPro	SPDGxxx-120M12				
SunTech	STP, STPXXXS - B60/Wnhb				
Talesun	Hipor M, Smart, TD6I72M, TD7G72M, TP572, TP596, TP654, TP660, TP672, TP6L72M-450, TP7G54M(H), TM7G54M TM3G48M TM7G60M TM3G54M TM7G72M TM3G66M TP6F72M TP6F72M(H)				

- Unless otherwise noted, all modules listed above include all wattages and specific models within that series. Variable wattages are represented as "xxx"
- Items in parenthesis are those that may or may not be present in a compatible module's model ID
- Slashes "/" between one or more items indicates that either of those items may be the one that is present in a module's model ID
- The frame profile must not have any feature that might interfere with the bonding devices that are integrated into the racking system
- Use with a maximum over current protection device OCPD of 30A
- **Listed models can be used to achieve a Class A fire system rating for steep slope and low slope applications. See page 33**

Electrical Bonding and Grounding Test Modules

The list below is not exhaustive of compliant modules but shows those that have been evaluated and found to be electrically compatible with the SOLARMOUNT system.

Manufacture	Module Model / Series
Yingli	YGE & YLM Series
Yotta Energy	YSM-B450-1
ZNShine	ZXM6-72 Series, ZXM6-NH144 ZXM6-NH120 Series ZXM6-NHLDD144 ZXM7-SH108 Series ZXM7-SHDB144 ZXM7-SHLDD144 ZXM7-UHLDD144 ZXM8-GPLDD132 Series ZXM8-TPLDD132

- Unless otherwise noted, all modules listed above include all wattages and specific models within that series. Variable wattages are represented as "xxx"
- Items in parenthesis are those that may or may not be present in a compatible module's model ID
- Slashes "/" between one or more items indicates that either of those items may be the one that is present in a module's model ID
- The frame profile must not have any feature that might interfere with the bonding devices that are integrated into the racking system
- Use with a maximum over current protection device OCPD of 30A
- **Listed models can be used to achieve a Class A fire system rating for steep slope and low slope applications. See page 33**



INSTALL FLASHKIT PRO FLASHING



INSTALL L-FOOT



ATTACH L-FOOT TO RAIL

PRE-INSTALL

- Locate roof rafters and snap chalk lines to mark the installation point for each roof attachment.
- Drill a 7/32" pilot hole at each roof attachment. Fill each pilot hole with sealant.

STEP 1 INSTALL FLASHKIT PRO FLASHING

- Add a U-shaped bead of roof sealant to the underside of the flashing with the open side of the U pointing down the roof slope. Slide the aluminum flashing underneath the row of shingles directly up slope from the pilot hole as shown. Align the indicator marks on the lower end of the flashing with the chalk lines on the roof to center the raised hole in the flashing over the pilot hole in the roof. When installed correctly, the flashing will extend under the two courses of shingles above the pilot hole.

STEP 2 INSTALL L-FOOT

- Fasten L-foot and Flashing into place by passing the included lag bolt and pre-installed stainless steel-backed EPDM washer through the L-foot EPDM grommet, and the raised hole in the flashing, into the pilot hole in the roof rafter.

- Drive the lag bolt down until the L-foot is held firmly in place. It is normal for the EPDM on the underside of the stainless steel backed EPDM washer to compress and expand beyond the outside edge of the steel washer when the proper torque is applied.

TIP:

- Use caution to avoid over-torquing the lag bolt if using an impact driver.
- Repeat Steps 1 and 2 at each roof attachment point.

STEP 3 ATTACH L-FOOT TO RAIL

- Insert the included 3/8"-16 T-bolts into the lower slot on the Rail (sold separately), spacing the bolts to match the spacing between the roof attachments.
- Position the Rail against the L-Foot and insert the threaded end of the T-Bolt through the continuous slot in the L-Foot. Apply anti-seize to bolt threads to prevent galling of the T-bolt and included 3/8" serrated flange nut. Place the 3/8" flange nut on the T-bolt and finger tighten. Repeat STEP 3 until all L-Feet are secured to the Rail with a T-bolt. Adjust the level and height of the Rail and torque each bolt to 30ft-lbs.

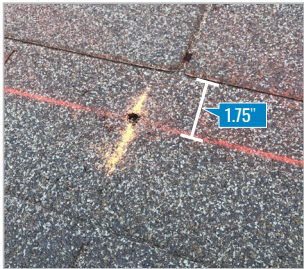

PRE-INSTALL

Snap chalk lines for attachment rows. On shingle roofs, snap lines 1-3/4" below upslope edge of shingle course. Locate rafters and mark attachment locations.

At each location, drill a 7/32" pilot hole. Clean roof surface of dirt, debris, snow, and ice. Next, BACKFILL ALL PILOT HOLES WITH SEALANT.

NOTE: Space mounts per racking system install specifications.



STEP 1: SECURE

Place **FLASHLOC** over pilot hole with lag on down-slope side. Align indicator marks on sides of mount with chalk line. Pass included lag bolt and sealing washer through **FLASHLOC** into pilot hole. Drive lag bolt until mount is held firmly in place.

NOTE: The EPDM in the sealing washer will expand beyond the edge of the metal washer when proper torque is applied.



STEP 2: SEAL

Insert tip of UNIRAC provided sealant into port. Inject until sealant exits both vents. Follow sealant manufacturer's instructions. Follow sealant manufacturer's cold weather application guidelines, if applicable.

Continue array installation, attaching rails to mounts with provided T-bolts.



NOTE: When **FLASHLOC** is installed over gap between shingle tabs or vertical joints, fill gap/joint with sealant between mount and upslope edge of shingle course.

USE ONLY UNIRAC APPROVED SEALANTS: Chemlink Duralink 50, Chemlink M-1, Geocel 4500, or Geocel S-4



PRE-INSTALL CLEAN SURFACE AND MARK LOCATION

Ensure existing roof structure is capable of supporting loads prescribed in Flashloc Duo D&E Guide. Clean roof surface of dirt, debris, snow and ice.

Snap chalk lines for attachment rows. On shingle roofs, snap lines 1/4" below upslope edge of shingle course. This line will be used to align the upper edge of the mount.

NOTE: Space mounts per span charts found in Flashloc Duo D&E Guide.



STEP ONE: SECURE

ATTACHING TO A RAFTER: Place FLASHLOC DUO over rafter location and align upper edge of mount with horizontal chalk line. Secure mount with the two (2) provided rafter screws. **BACKFILL ALL PILOT HOLES WITH SEALANT.**

ATTACHING TO SHEATHING: Place FLASHLOC DUO over desired location and align upper edge of mount with horizontal chalk line. Secure mount with the two (2) provided rafter screws. Next, secure mount with four (4) deck screws by drilling through the FLASHLOC DUO deck mount hole locations. Unirac recommends using a drill as opposed to an impact gun to prevent over-tightening or stripping roof sheathing.

IMPORTANT: SECURELY ATTACH MOUNT BUT DO NOT OVERTIGHTEN SCREWS.



STEP TWO: SEAL

Insert tip of UNIRAC approved sealant into port and inject until sealant exits vent.

Continue array installation, attaching rails to mounts with provided T-bolts. Follow sealant manufacturer's instructions. Follow sealant manufacturer's cold weather application guidelines, if applicable.

NOTE: When FLASHLOC DUO is installed over gap between shingle tabs or vertical joints, fill gap/joint with sealant between mount and upslope edge of shingle course.



CUT SHINGLES AS REQUIRED: DO NOT INSTALL THE FLASHLOC SLIDER ACCROSS THICKNESS VARIATIONS GREATER THAN 1/8" SUCH AS THOSE FOUND IN HIGH DEFINITION SHINGLES.

NOTE: When installing included rail attachment hardware, torque T-bolt nut to 30 ft-lbs.

NOTE: If an exploratory hole falls outside of the area covered by the sealant, flash hole accordingly.

USE ONLY UNIRAC APPROVED SEALANTS. PLEASE CONTACT UNIRAC FOR FULL LIST OF COMPATIBLE SEALANTS.

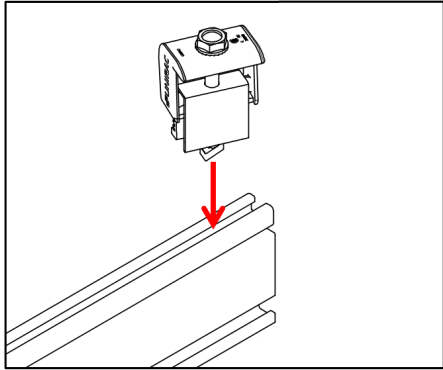

STEP 1: Position clamp to align T-bolt with rail slot. Lower clamp and Insert T-bolt into rail slot.

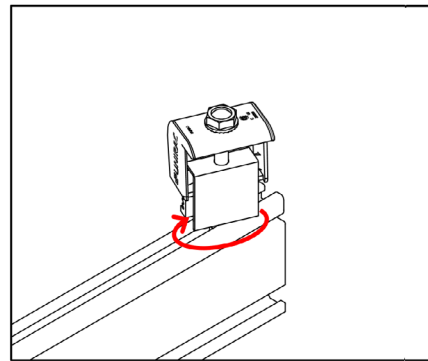

STEP 2: Rotate clamp clockwise 2/3 of a turn to engage T-bolt inside rail slot.

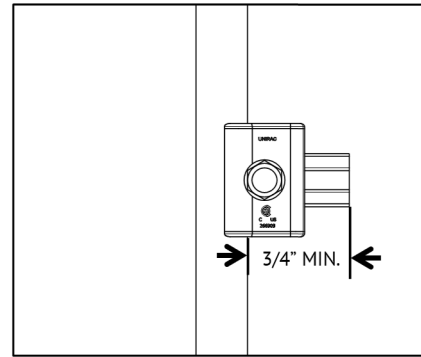

STEP 3: Place module at least 3/4" from end of rail and position clamp against module frame.

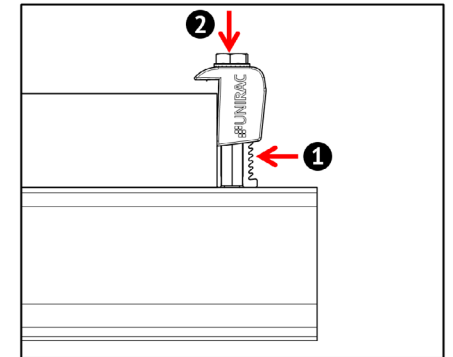

STEP 4: While applying pressure to hold the clamp against the module, push down on the module side of the clamp cap.

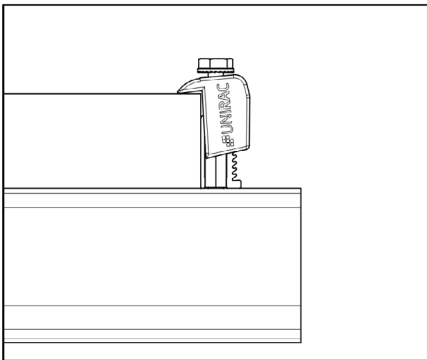

STEP 5: When the cap contacts the module frame, release and it will re-engage to the clamp base.

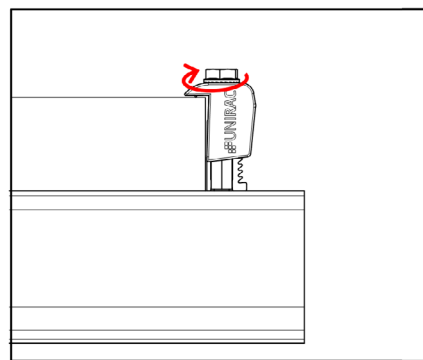

STEP 6: Tighten bolt and torque to 15 ft-lbs.

NOTE - Universal AF End Clamps are single use.

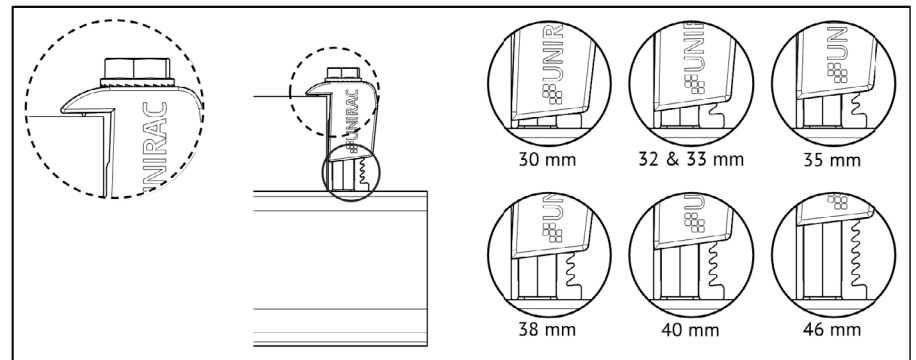

STEP 7: Confirm clamp is engaged in correct module height position and that the top of the cap is sitting level with the module frame.

NOTE: When installing 46mm modules, loosen bolt by 1 turn before positioning clamp against module frame. Do not force clamp onto module frame as this may damage the bonding pin.

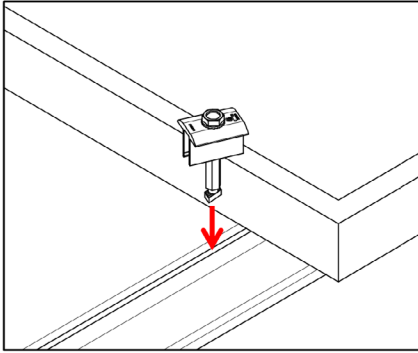

STEP 1: Position clamp to align T-bolt with rail slot. Lower clamp and insert T-bolt into rail slot

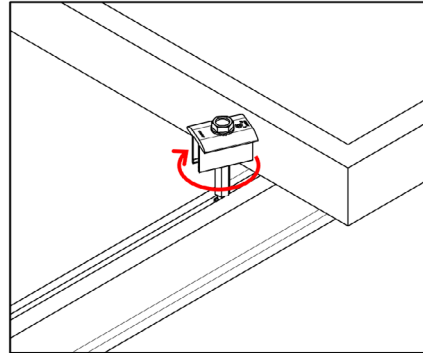

STEP 2: Rotate clamp clockwise 2/3 of a turn to engage T-bolt inside rail slot.

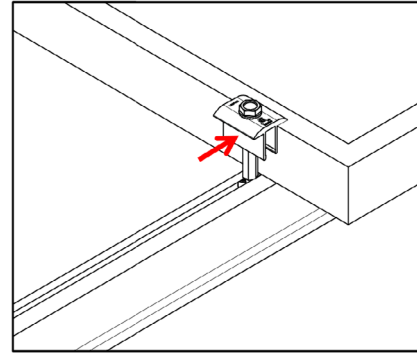

STEP 3: Slide clamp into position against module.

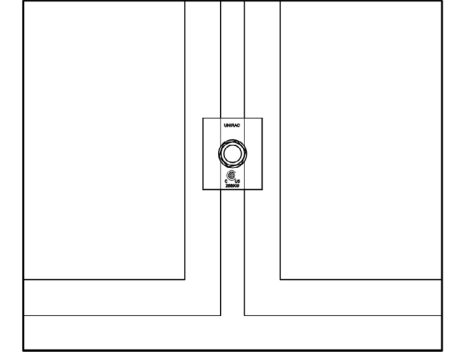

STEP 4: Place second module.

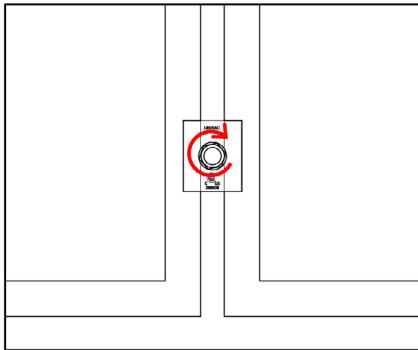

STEP 5: Tighten bolt and torque to 15 ft-lbs.

NOTE - Universal AF Mid Clamps are single use.

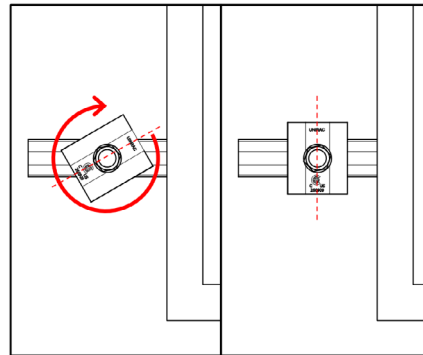

NOTE: If excessive force is applied in step 2, the cap may over-rotate causing it to be mis-aligned with the module frame. If this occurs, keep rotating the cap clockwise until it returns to the original position.

S-5! COMPONENTS

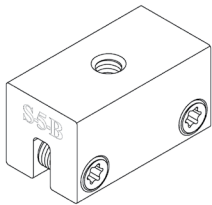

S-5-B

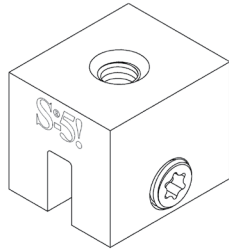

S-5-B Mini

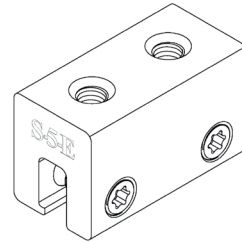

S-5-E

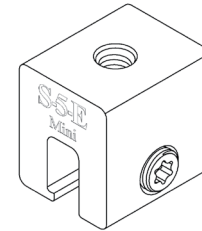

S-5-E Mini

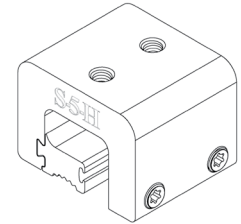

S-5-H

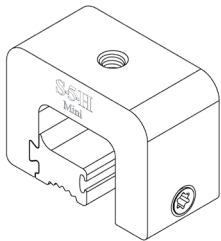

S-5-H mini

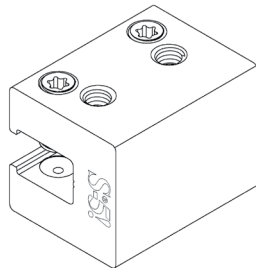

S-5-H90

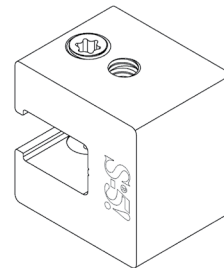

S-5-H90 Mini

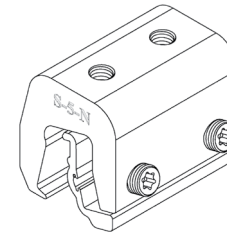

S-5-N

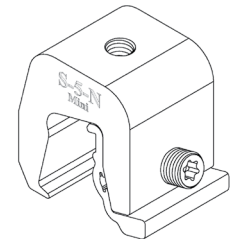

S-5-N Mini

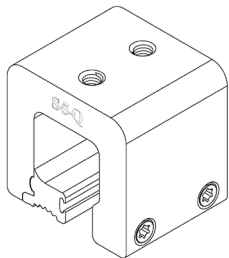

S-5-Q

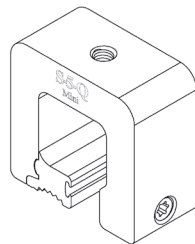

S-5-Q Mini

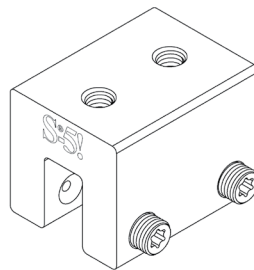

S-5-S

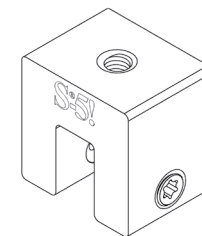

S-5-S Mini

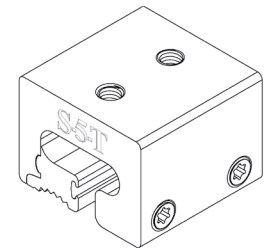

S-5-T

S-5! COMPONENTS

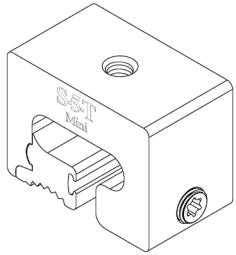

S-5-T mini

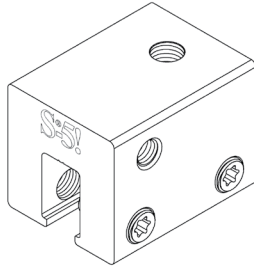

S-5-U

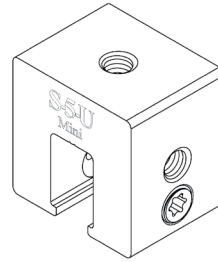

S-5-U Mini

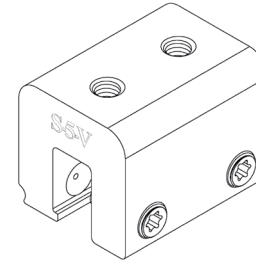

S-5-V

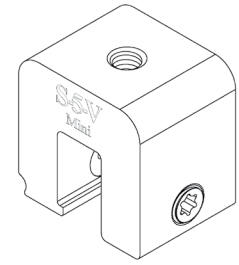

S-5-V Mini

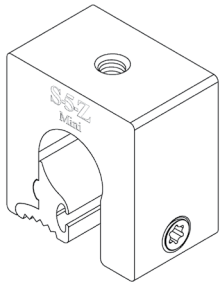

S-5-Z

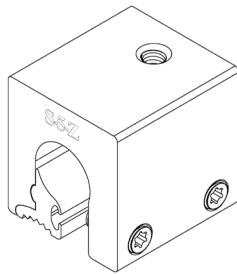

S-5-Z mini

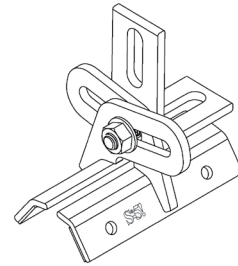

Protea Bracket

S-5! STANDING SEAM CLAMPS AND PROTEA BRACKET INSTALLATION

STEP 1: Follow the instructions provided on <https://buys-5.com/> for installing the S-5! standing seam clamps and Protea bracket on the metal roof.

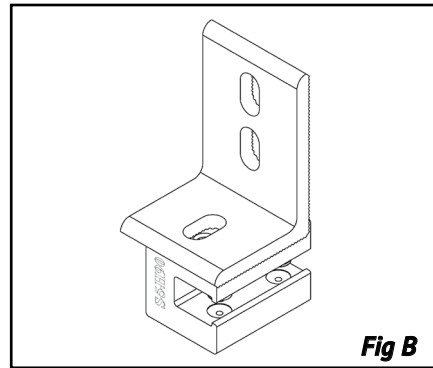
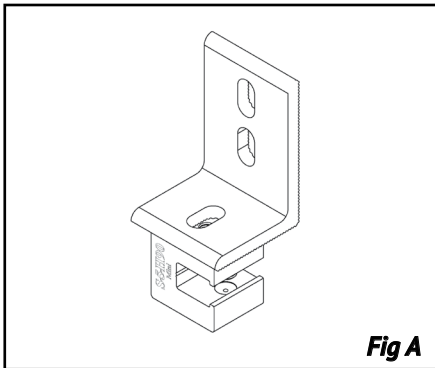

STEP 2: POSITION L-FOOT

Position L-foot on S-5-H90 Mini clamp or S-5-H90 clamp to align holes as shown in Fig A and Fig B respectively.

Similarly, position L-Foot on any S-5! clamps mentioned on [pages 45 & 46](#)

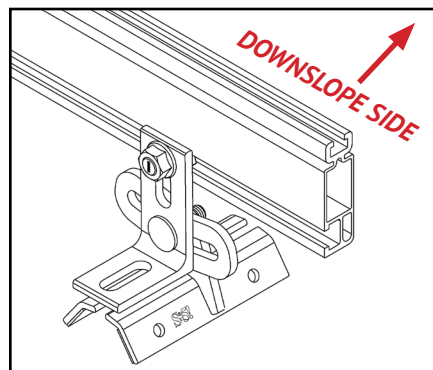
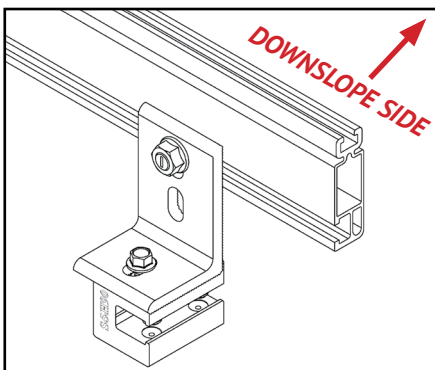

STEP 4: SECURE RAIL TO L-FOOT OR PROTEA BRACKET

Follow the steps mentioned on [page 24](#) to secure Rail to L-Foot or Protea Bracket

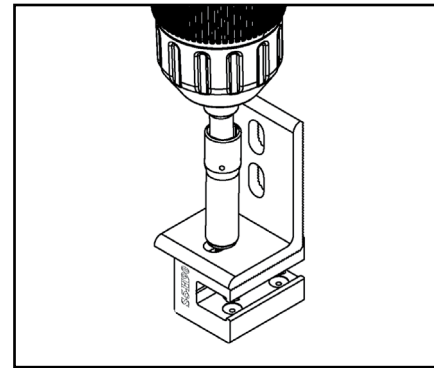

STEP 3: SECURE L-FOOT

Use M8-1.25 x 17 mm bolt to secure the L-Foot to the clamp.

Torque bolt to 13 ft-lbs

NOTE:

It is recommended to maintain least possible distance between the upright leg of the L-foot and the bolt center.

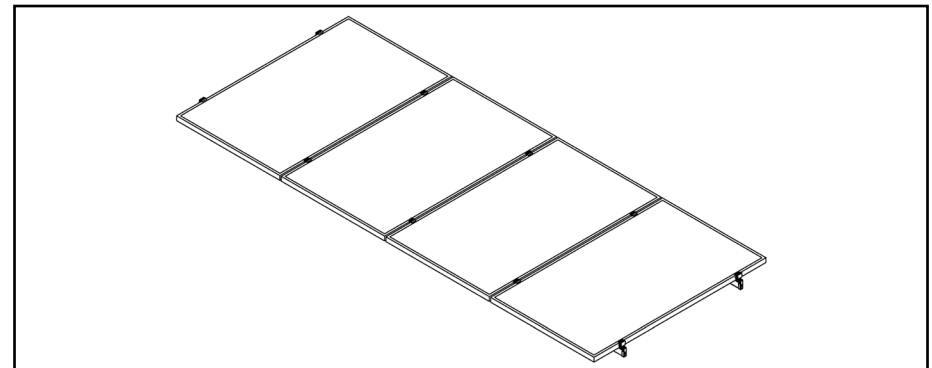
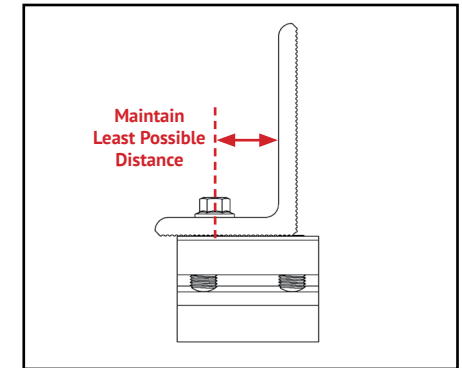

STEP 5: COMPLETE SYSTEM INSTALLATION

Complete the SolarMount installation as per instructions in previous sections of the installation manual based on the type of clamps and specific components being installed. Ensure the system is properly grounded and bonded as per the Bonding Connections Ground Paths section that applies to your installation.

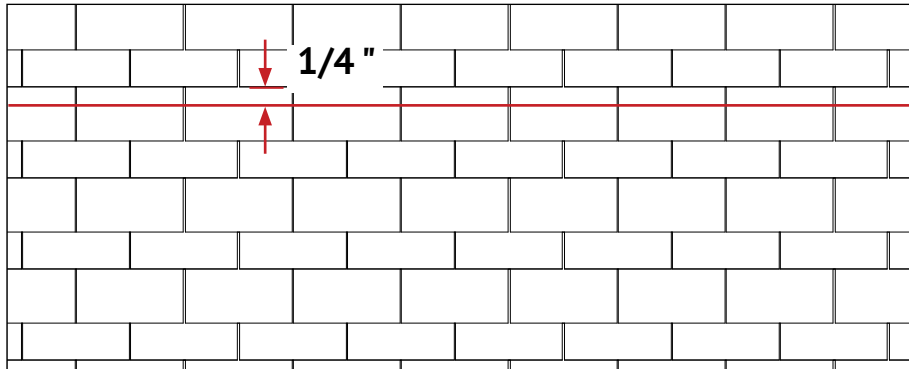

MARK ARRAY LOCATION:

Clean roof surface of dirt, debris, snow, and ice. Mark array location and determine roof attachment locations based on array layout. Snap chalk lines to mark each row of roof attachment points. On shingle roofs, snap lines 1/4" below upslope edge of shingle course. Locate rafters and mark at intersection of attachment lines. Attachment spacing determined per Design and Engineering Guide or project specific U-Builder Engineering Report .

PRO TIP

Install the attachment within 1/4" of the chalkline to allow the rail to slide freely in the rail clamp.

WARNING

- To maintain butyl flashing performance, Unirac does not recommend installing when ambient and/or roof temperatures are below 5°F or above 180°F.
- SM Butyl attachment must be installed on a clean, dry surface to ensure flashing integrity.

NOTE:

- SM Butyl attachment is designed for use on Asphalt Shingle, Rolled Comp, EPDM, TPO, Polyethylene, Polypropylene, ABS, and Metal Roofs (including Galvalume, painted steel, and galvanized).
- Pilot holes are not necessary to be drilled for self-drilling screws. If holes are drilled to identify the rafter, they should be backfilled with sealant before installing the attachment.
- SM Butyl attachment is designed for slopes ranging from 0 to 90-degrees. For installations over 45-degrees, contact Unirac engineering for design guidance.

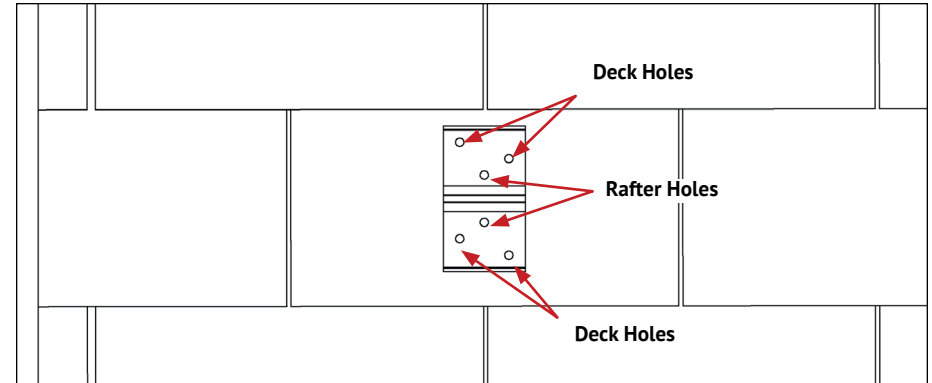

PLACE SM BUTYL ATTACHMENT BASE:

Identify the position of the attachment to install before peeling the release paper. Ensure that the attachment lands on a flat surface. If the surface at the location of the attachment is uneven, add butyl patches to flatten the surface.

Note:

- Use rafter holes to install attachment on the rafter.
- Use all six holes to install attachment on the deck.

CAUTION

Do not peel the release paper from the butyl on attachment before identifying the position of attachment to install.

WARNING

Installing attachment on uneven surfaces, shingle gaps or overlaps, creates a risk for water leakage due to gap created between the adhesive and roof surface.

Note:

See Page 51 for instructions on placing extra butyl pads or contact Unirac team for further information.

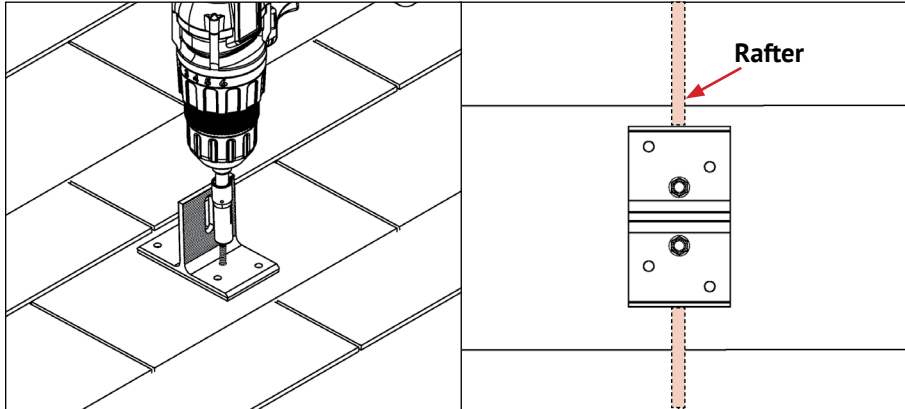

INSTALLING SM BUTYL ATTACHMENT BASE TO RAFTER:

Peel-off the release paper from the underside of the attachment and place attachment over rafter location and align edge of attachment with horizontal chalk line. Secure attachment with the two (2) provided rafter screws in the rafter holes of the attachment.

Note:
 Ensure to use drill extension or deep socket tool for installing rafter screws.

CAUTION

- To determine if the screw is engaging the rafter, there should be resistance to driving the screw through the entire length. If the screws do not properly engage the rafter, refer to the pro tip mentioned.
- It is recommended to begin installation with the screws on the upslope side of the attachment and continue installing the screws on the downslope side of the attachment for best fit.

WARNING

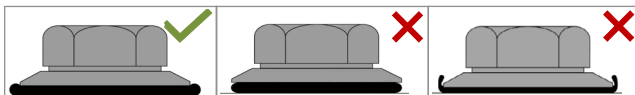

Do not over-torque the structural screw.
 When proper torque is applied, the EPDM washer should slightly expand out from the sides as shown in the image.

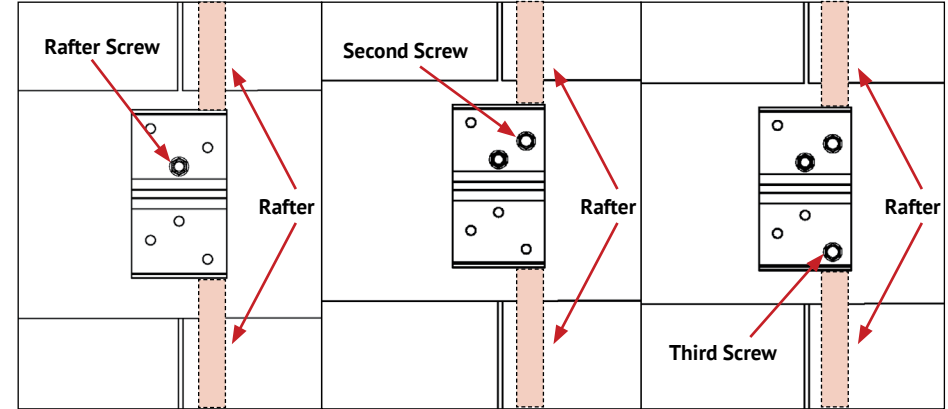

PRO TIP:

If you miss the rafter while driving the first screw and the rafter is on the edge of the attachment, then follow the steps below:

1. Install a second screw into the adjacent hole that is closest to the rafter center.
2. If the second screw hits the rafter, install the corresponding third screw and complete the installation.
3. If three or more screws miss the rafter, then follow the direct to deck installation procedure and reduce the attachment spans as per Unirac direct-to-deck recommended spans for roof attachment.

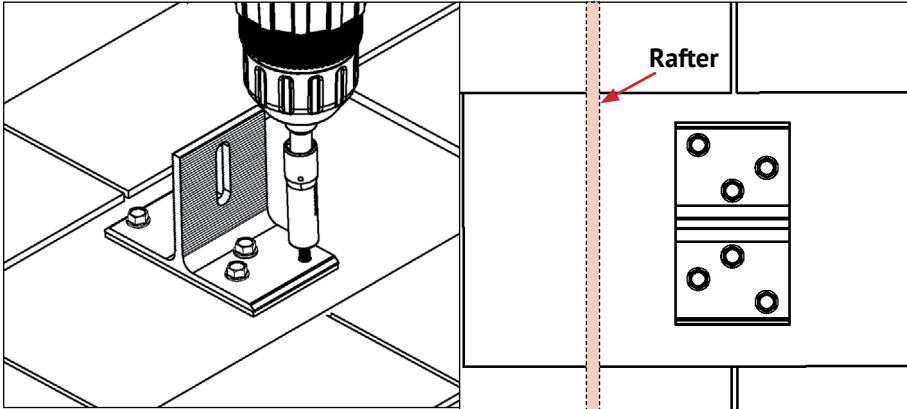

INSTALLING SM BUTYL ATTACHMENT BASE TO DECK:

When installing the attachment to the decking instead of the rafter (direct-to-deck), install 4 additional screws on the remaining screw holes on the attachment

Note:

- Additional deck screws are NOT included in the KIT. Must be purchased separately.
- Maintain stock of additional deck screws from Unirac Kits in case of direct-to-deck installation.

CAUTION

1. Allowable attachment spans may change for direct-to-deck applications.
2. Unirac recommended spans are only valid with Unirac supplied screws.

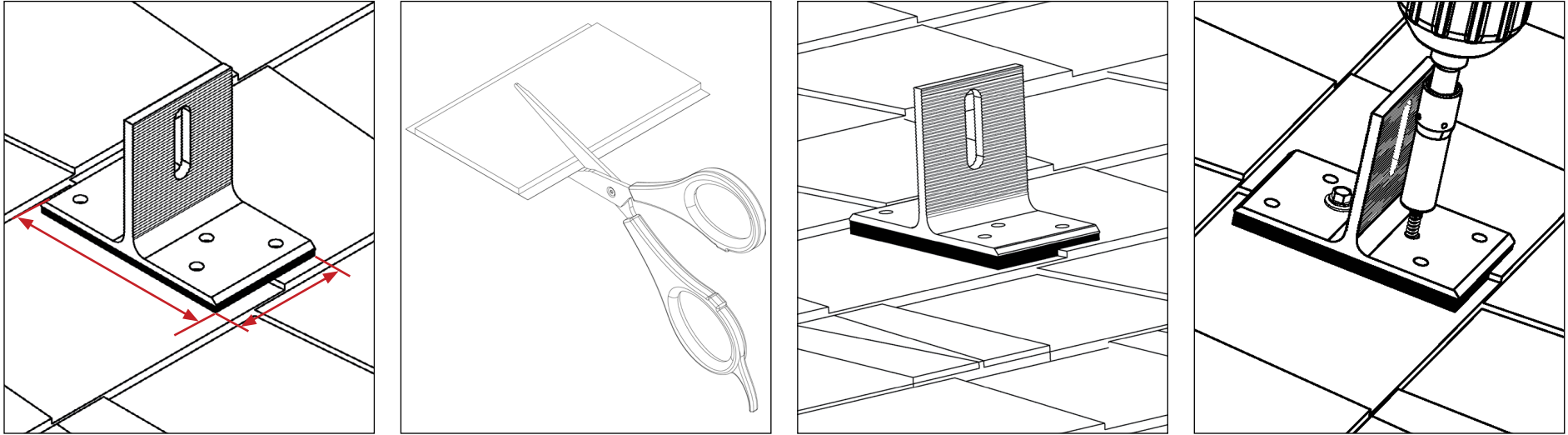

INSTALLING SM BUTYL ATTACHMENT OVER SHINGLE OVERLAP

If the attachment falls over a shingle overlap, level the surface by following below steps:

- Measure the attachment overhang.
- Cut the butyl pads to required size.
- Stack extra butyl pad layers as necessary to level the roof and place the attachment.
- Begin installation with the screws on the upslope side of the attachment and continue to install the screws on the downslope side of the attachment.

PRO TIP

- If the attachments overlap from one shingle course to the next shingle course in a rail-based system, reposition the attachment by moving up or down the shingle course along the same rafter line to avoid butyl layering.
- Additional butyl layering is not required while installing attachment over a gap in the same shingle course

Note:

- Extra butyl pads are **NOT** included in the KIT.
- Pre-stock with extra butyl pads from Unirac Kits in case installation is required over overlap or gap.



Installing attachment on uneven surfaces, shingle gaps or overlaps, creates a risk for water leakage and rail clamp misalignment due to gap created between the adhesive and roof surface.

