

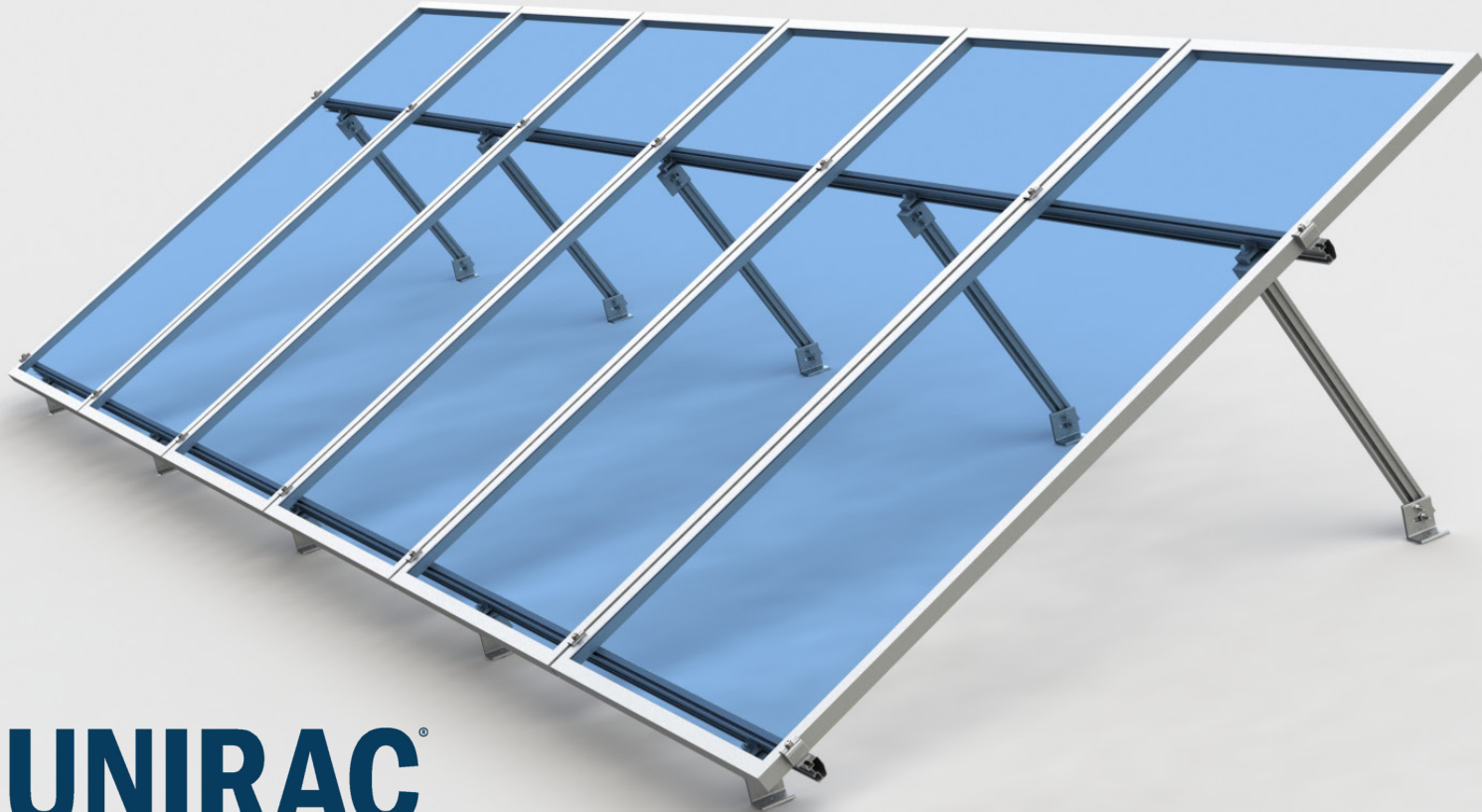

SOLARMOUNT ASCENDER
1-ROW NON ELEVATED

INSTALLATION GUIDE



 **UNIRAC**[®]

UNIRAC Code-Compliant Installation Manual

© 2023 by Unirac, Inc. All rights reserved.

UNIRAC welcomes input concerning the accuracy and user-friendliness of this publication. Please write to publications@unirac.com.

PUB2026JAN23



SOLARMOUNT ASCENDER
1-ROW NON ELEVATED

INSTALLATION GUIDE

TABLE OF CONTENTS	PG
SYSTEM COMPONENTS.....	1-2
SYSTEM LAYOUT.....	3
THERMAL BREAK.....	4
SYSTEM SETUP DISTANCES.....	5
SYSTEM INSTALLATION STEPS.....	6-18
MICRO INVERTER MOUNTING.....	19
STANDARD SYSTEM GROUNDING.....	20
BONDING CONNECTIONS AND GROUNDING PATHS.....	21-24
CODE COMPLIANCE NOTES.....	25
MECHANICAL LOAD TEST.....	26
COMPATIBLE MODULES.....	27-32



SOLARMOUNT ASCENDER 1-ROW NON ELEVATED

SYSTEM COMPONENTS : 1 INSTALLATION GUIDE : PAGE

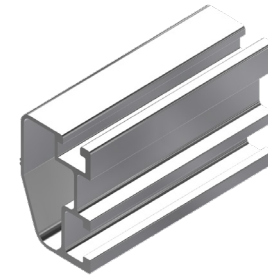
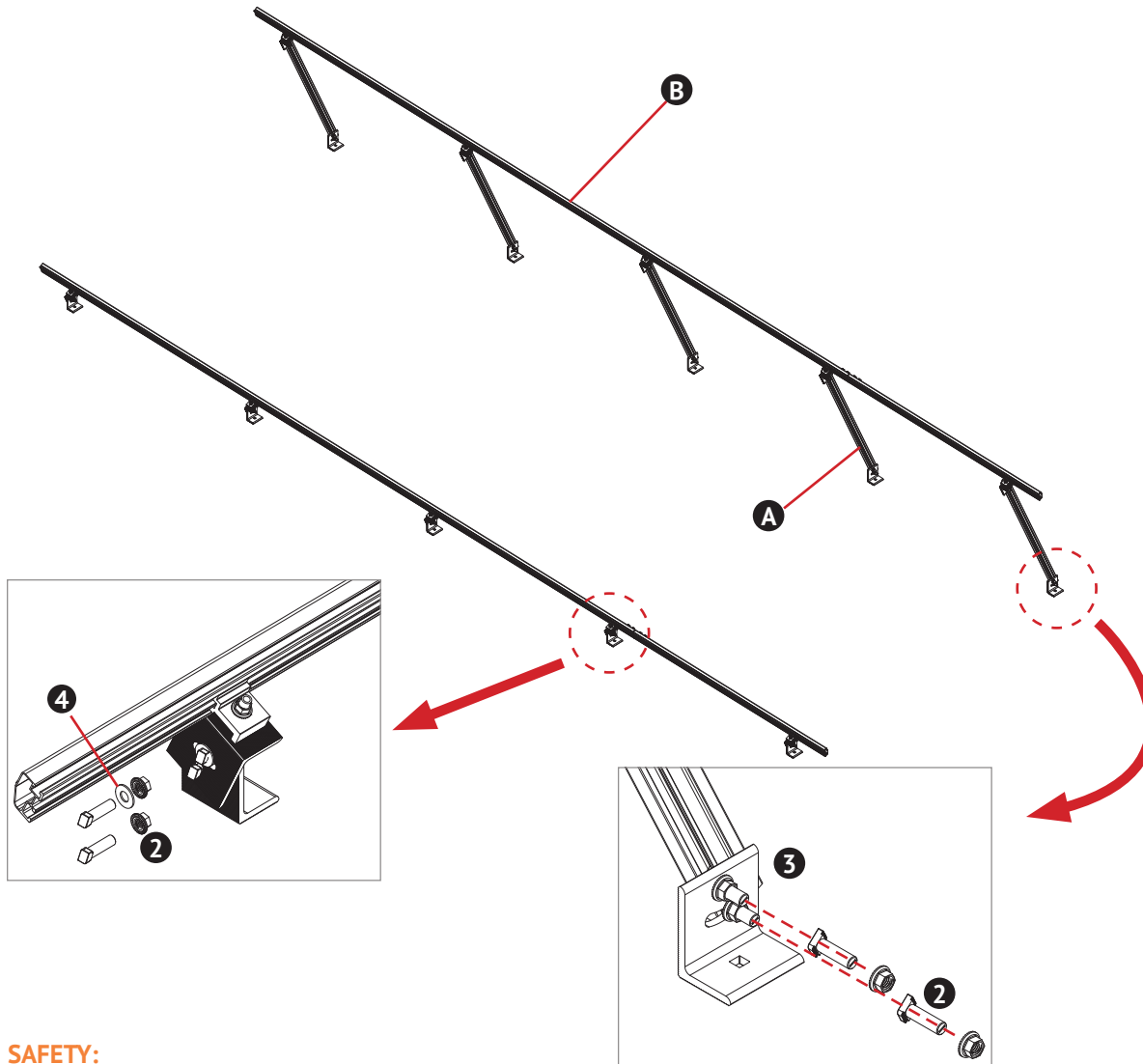

- 1 ASCENDER RAIL (A1R181M)**
Functions as **A** and **B**. Aluminum extrusion, available in mill finish.
 - A REAR TILT LEG** - Supports EW beam on the rear side. Use one Rear Tilt leg per frame/ bay.
 - B EW BEAM** - Supports PV module. Use two rails per row of modules. EW Beam runs in East-West direction.
- 2 T-BOLT AND SERRATED FLANGE NUT (3/8" X 1.2" SS) (009022S)**
Use on Tilt leg to Swivel L-Plate connection. Provides electrical bonding between rail and Swivel L-Plate to rail.
- 3 SWIVEL L-PLATE WITH HARDWARE (A1LF01M)**
(1) T-bolt and (1) serrated flange nut will be shipped with swivel L-Plate. Use swivel L-Plate to secure the Tilt legs to attachment.
- 4 WASHER (to be sourced by customers)** – Use an SS 18-8 passivated washer with a 0.75" outer diameter, which must accommodate 3/8" screw size with T-bolt to prevent disengagement as shown in the picture.

SAFETY:

All applicable OSHA safety guidelines should be observed when working on a PV installation job site. The installation and handling of PV solar modules, electrical installation and PV racking systems involves handling components with potentially sharp metal edges. Rules regarding the use of gloves and other personal protective equipment should be observed.

Note: Use Ascender Design tool to check how many washers are necessary—the part will be specified on the Bill of Materials (BOM).



SOLARMOUNT ASCENDER 1-ROW NON ELEVATED

SYSTEM COMPONENTS: 2 INSTALLATION GUIDE: PAGE

S.no.	Required Tools
1	Torque Wrench
2	Impact Wrench
3	1/2" Socket
4	Saw
5	Measuring Tools
6	5/16" Drill Bit

S.no. - Serial Number

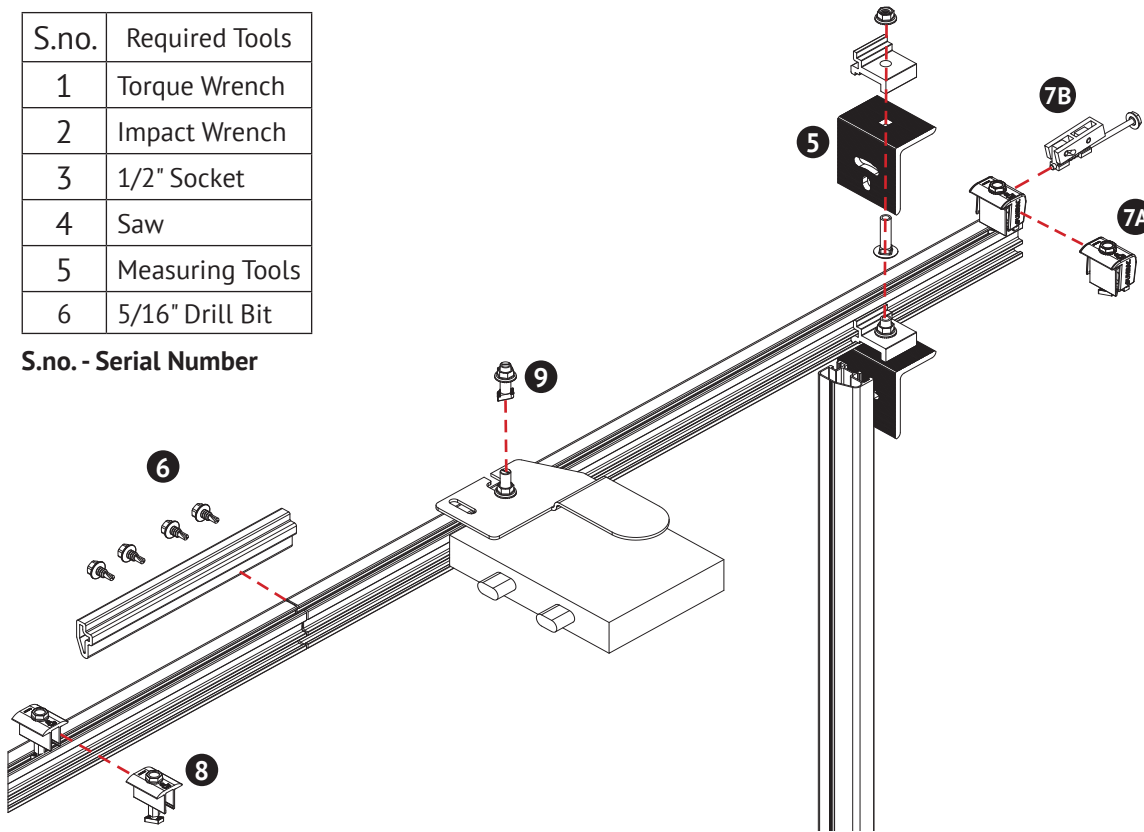

- 5 ASCENDER ALT BEAM CLIP ASSEMBLY (A1BC201)**
Pre-assembled alternate beam clip assembly contains Carriage bolt, serrated flange nut, Beam clip, Swivel L-Plate. Connects the EW beam to the tilt legs or anchored Swivel L-Plate.
- 6 ASCENDER SPLICE WITH HARDWARE (A1SP02M)**
4 - 5/16"-18 X 0.75" SS Hex Head Drilling Screws will be shipped with splice. Connects EW beam to EW beam. Structural splice joins, aligns and electrically bonds rail sections into single length of rail. Forms a rigid splice joint, 10 inches long, assembled with bonding hardware. Use 4 screws per splice.
- 7A MODULE UAF END CLAMP (302050M) /**
7B MODULE PRO SERIES END CLAMP (302035M)
Pre-assembled clamp that secures module to rail at module flange by tightening 1/2" Hex Bolt.
- 8 MODULE MID CLAMP (302045M)**
Pre-assembled universal clamp provides module to module and module to rail bond. Aluminum clamp with stainless steel bonding pins and T-Bolt.
- 9 MICROINVERTER MOUNTING BOLT(0080135)**
Pre-assembled bolt, nut and captive star washer attaches and bonds microinverter to rail.

Wrenches and Torques		
Description	Wrench or Socket Size	Recommended Torque (ft-lbs)
3/8" T-Bolt 3	1/2"	30
Beam Clip 5		15
Rail Splice Bolt 6		20
UAF End Clamp 7A		15
Pro Series End Clamp 7B		5
UAF Mid Clamp 8		15
Micro Inverter Mounting Bolt 9		10

Anti-Seize

Stainless steel hardware can seize up, a process called galling. To significantly reduce its likelihood:

1. Apply minimal lubricant to bolts only where indicated in installation process, preferably Anti-Seize commonly found at auto parts stores (Anti-seize has been factory applied to mid clamp bolts)
2. Shade hardware prior to installation, and
3. Avoid spinning stainless nuts onto bolts at high speed.

PLANNING YOUR ASCENDER INSTALLATIONS

Center the installation area over the structural members as much as possible. Leave enough room to safely move around the array during installation. Some building codes and fire codes require minimum clearances around such installations, and the installer should check local building code requirements for compliance.

PV modules to be installed in the Portrait orientation and modules to be installed facing true south only.

The total length of the installation area is equal to:

UAF Series:

- the total width of the modules
- plus 1/2" inch for each space between modules (for mid-clamp)
- plus approximately 1.5" inch (3/4" inches for each Endclamp)

UAF Mid Clamp and Pro Series End Clamp:

- the total width of the modules
- plus 1/2" inch for each space between modules (for mid-clamp)
- plus 0 to 1" (0 to 1/2 inches for each Endclamp)

STEPS TO AVOID SHADING LOSSES

- Please ensure the location selected for the installation of the structure is free of any objects in the close vicinity.
- For projects with multiple rows of structure, the installer need to ensure to set the pitch correctly to avoid the shadow of one structure on the other.

LAYING OUT L-FEET FOR TOP CLAMPS

Refer to the Ascender design tool for details of EW span and NS Spacing. Mark the locations for the L-feet within the installation area as shown in page 9.

NOTE:

- For expansion joint requirements, refer to page 4. Rail lengths and locations of L-feet for expansion joints will need to be determined at this stage in planning system layout.
- Refer to Ascender Design tool for allowable spans and cantilevers.

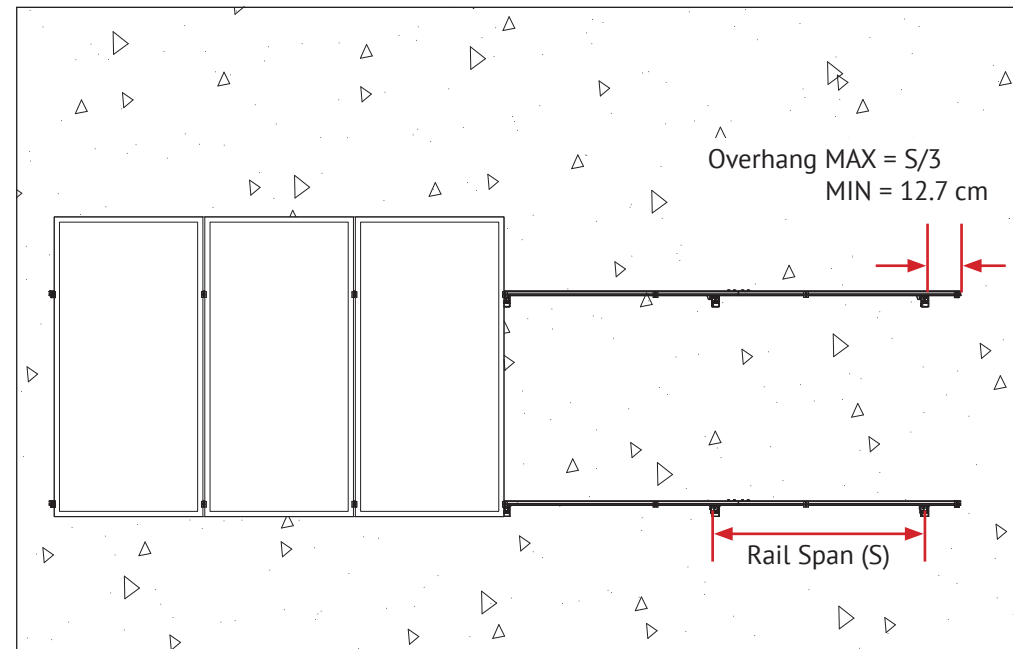

Figure shows Maximum and Minimum Overhang Limits

EXPANSION JOINT USED AS THERMAL BREAK

Expansion joints prevent buckling of rails or system connections failure due to thermal expansion. Determine location of expansion joints prior to installation of roof attachments and rails.

To create a thermal expansion joint, set gap between rails that is sufficient for proper installation of end clamps and tooling to achieve the required torque. In any case the thermal gap should never be less than 1.52cm.

Rails in expansion joint configurations are considered cantilevered and must follow the cantilever rule on both sides of the expansion joint. An expansion joint must not be spanned by a PV module. Installing a module over an expansion joint would defeat the goal of a thermal break and could result in damage to the array.

For temperature variations less than 120 °F, thermal break is not required up to 12 modules installed in a row. Thermal lengths for temperature variations greater than and equal to 120 °F are shown in table below:

Temperature variation (ΔT) in °F	Maximum continuous length (ft.) of spliced rails
120	45
140	39

For additional concerns on thermal breaks in your specific project, please consult a licensed structural engineer.

Determine the maximum rail temperature difference (ΔT) between the time of installation and the extreme high or low temperature. The Extreme Annual Design Conditions table at the following url can be used as a reference when determining ΔT . <http://ashrae-meteo.info/>. The installer is responsible for determining the maximum temperature difference (ΔT) used to establish the maximum rail length without expansion joint, at the install location.

As spans increase, so does the maximum reaction force that the rail exerts on the Swivel L-Plate. See Ascender design tool for corresponding reaction forces to ensure that the Maximum Reaction Forces do not exceed the shear capacity of the roof connection.

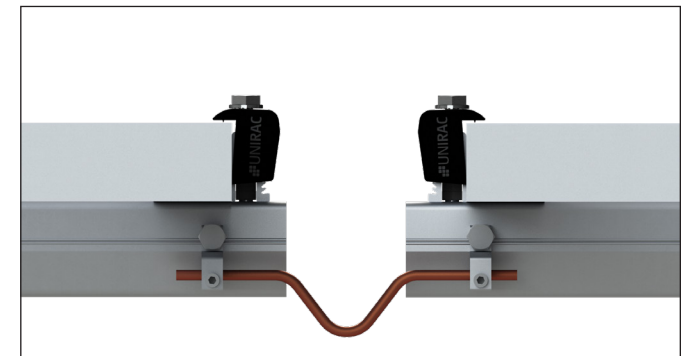
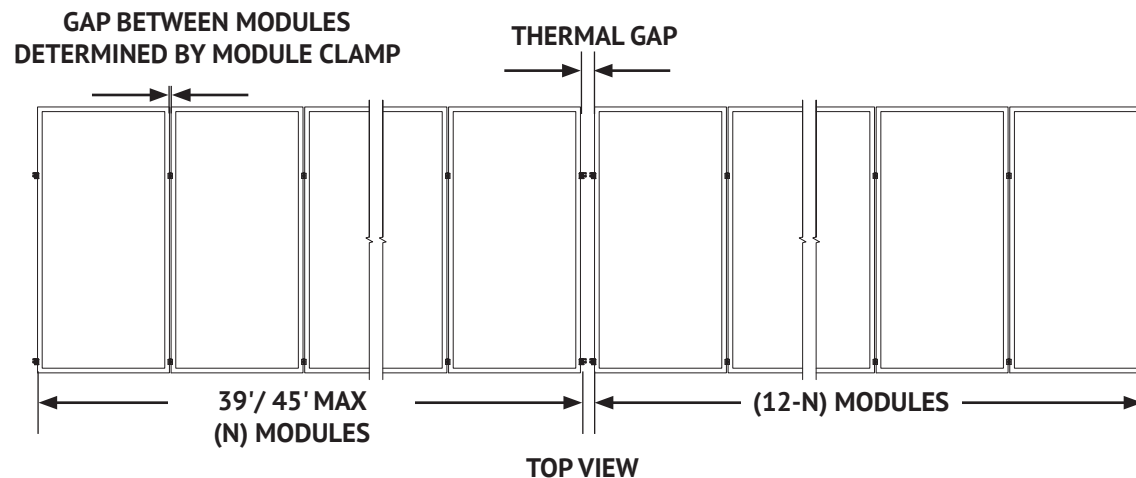

Bonding connection is used at a thermal break. Option shown uses two Ilco lugs (Model No. GBL-4DB P/N GBL-4DBT - see product data sheet for more details) and solid copper wire.



Tilt Angle (Range)	Roof Clearance Range (cm)
10° to 25°	10.16 to 12.7

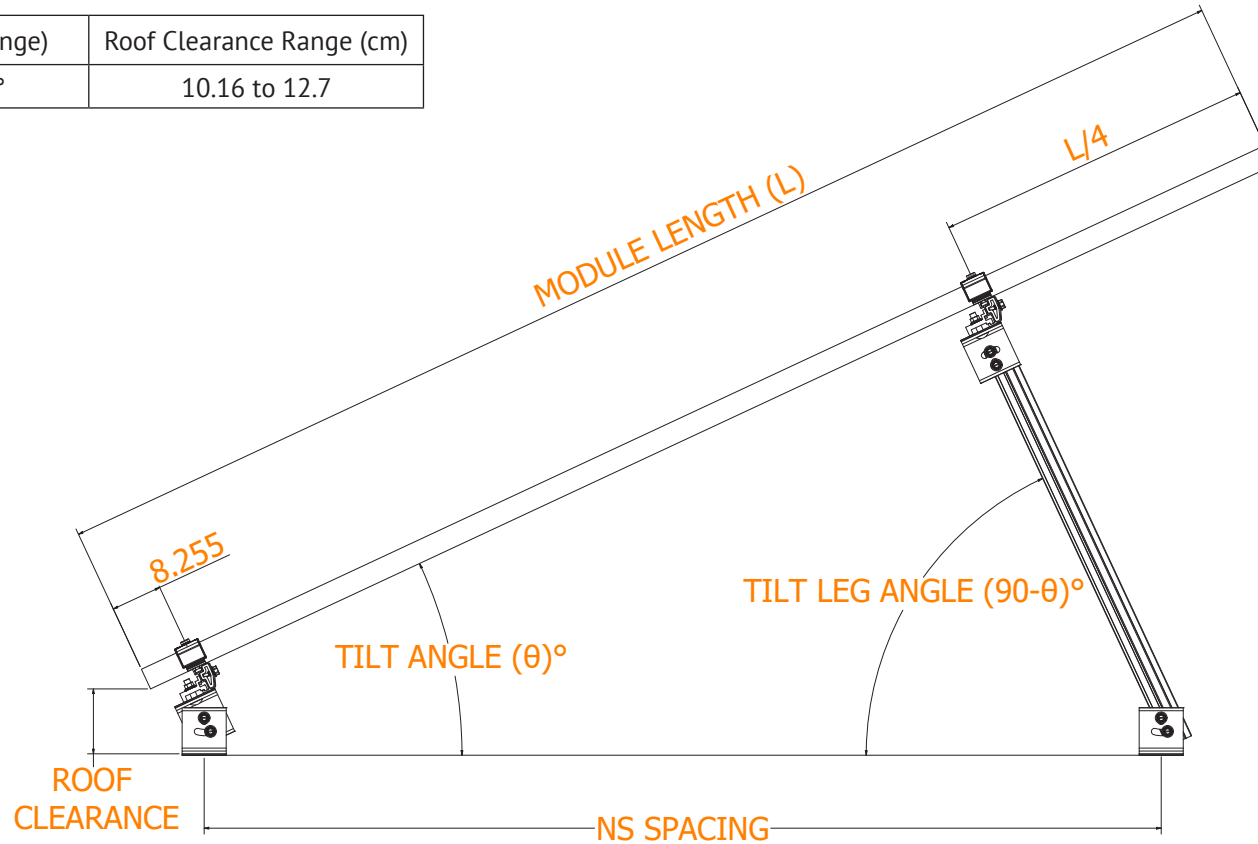

- Note down the NS spacing from tool for STEP 4. See page 9.
- Note down EW beams spacing for STEP 4 and STEP 11. See pages 9 and 12.
- Note down the Module overhang distance to position the module.

NOTE: All dimensions in the above figure are in centimeters. Module dimensions to be taken in centimeters for calculating other dimensions as mentioned in the figure.



COMMON STEPS FOR ALL T-BOLT INSTALLATIONS:-

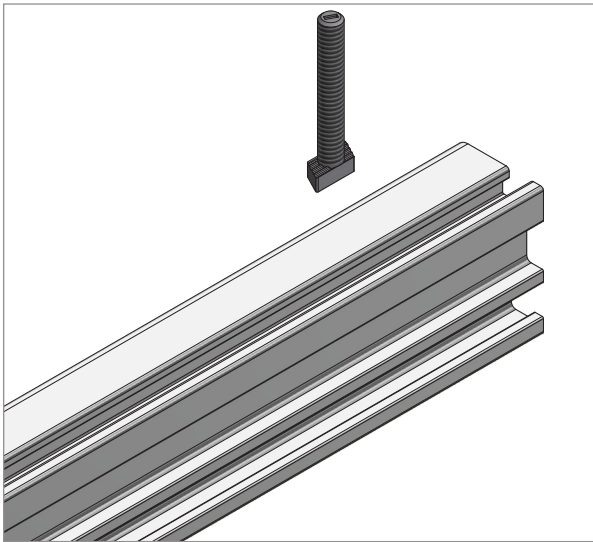

STEP A. INSERT T-BOLT

Insert T- Bolt into the rail and position the T-Bolt.

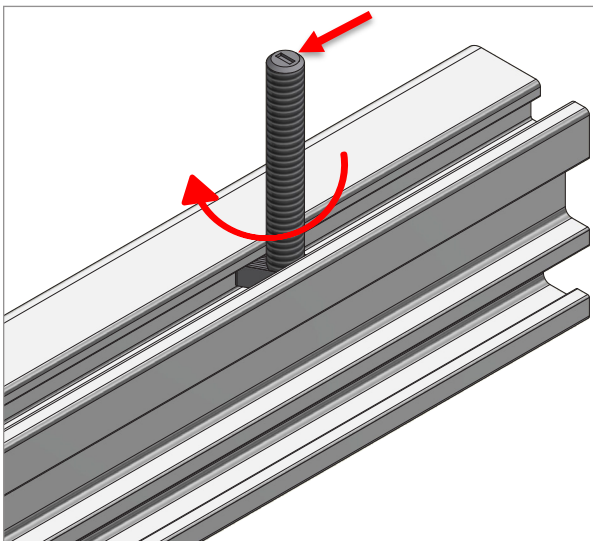

STEP B. ROTATE THE T-BOLT

Rotate T-Bolt into position. Verify that the position indicator on the T-Bolt shaft is angled perpendicular to the rail.



STEP 1. CUT RAIL INTO SECTIONS:

Cut rails into needed lengths and verify the count of each part. Refer to the Ascender design tool to find the length and quantities of the following parts:

Length & Quantities	1 : Tilt Post - Front	XXX cm
		XX c/u
	2 : Overall EW Beam	XXX cm
		XX c/u

C/U : Count per Unit.

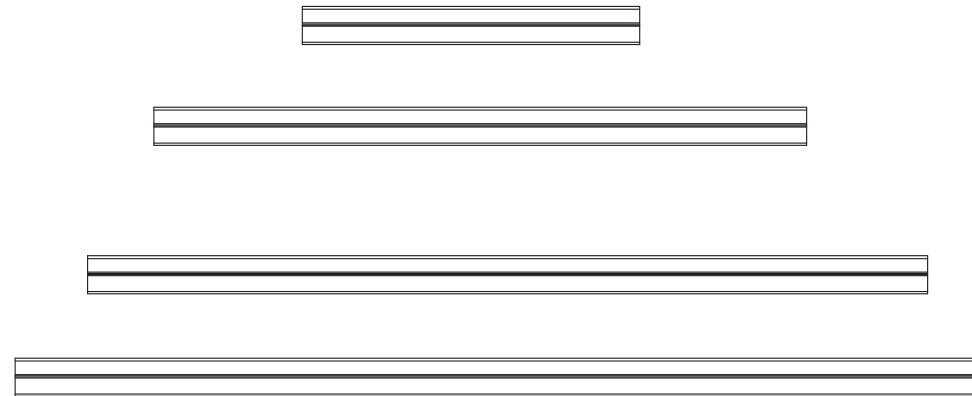

CUTTING GUIDE :

1. Cut the East-West Beam into the specified length. Measure before cutting to minimize waste.
2. Utilize excess rail after cutting the EW beam before using a new rail to make other members of the structure.
3. Minimize rail waste by considering the different length of the rail necessary for each member of the structure.
4. Cutting must be accurate to next millimeter. Any discrepancy in the lengths may result in difficulties during installation of the structure.
5. For installation on uneven sites, measure length of the members from the deepest undulation for the given span and build the first frame. The rest of the tilt legs must only be adjusted by shortening. Module clearance will vary depending on depth of undulations.

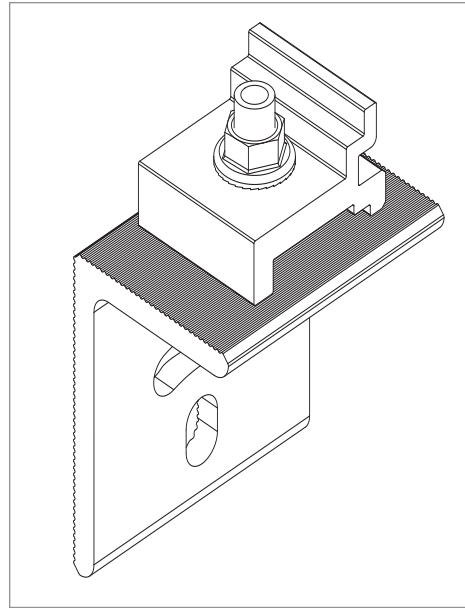
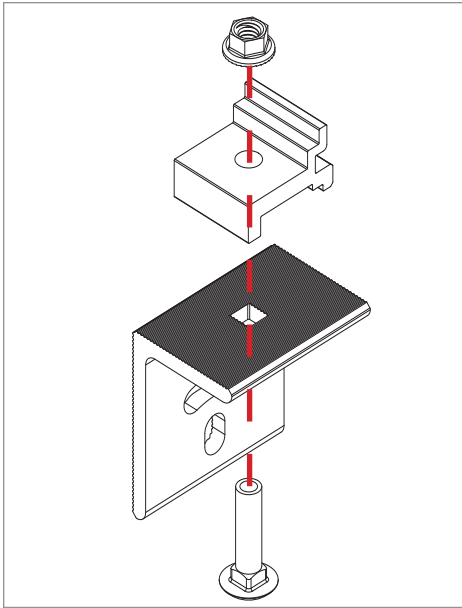

STEP 2. ASSEMBLE SWIVEL L-PLATE TO BEAM CLIP:

Assemble the part using the carriage bolt and nut included in the kit.

Do not tighten nut in this step.

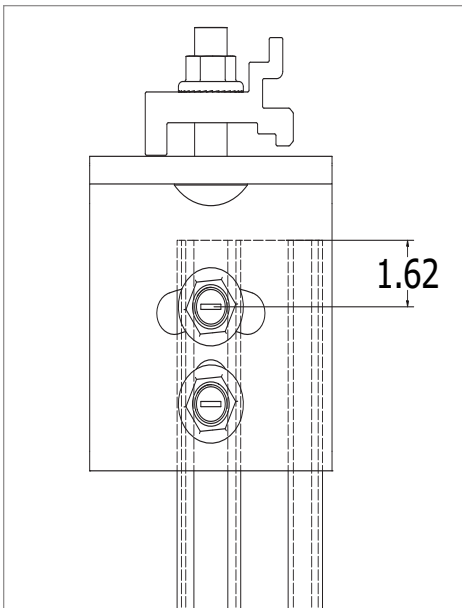

STEP 3. ATTACH ALT BEAM CLIP ASSEMBLY TO TILT LEGS

Attach Alt Beam Clip assembly to Tilt legs using two T-bolts. Install assembly parallel to the tilt legs. Install T-Bolt at a distance of 1.62 cm from the face of the rail as shown in the figure.

Note: Above installation has to be done while keeping the tilt legs on the ground.

Torque 3/8" nut to 30 ft-lbs.

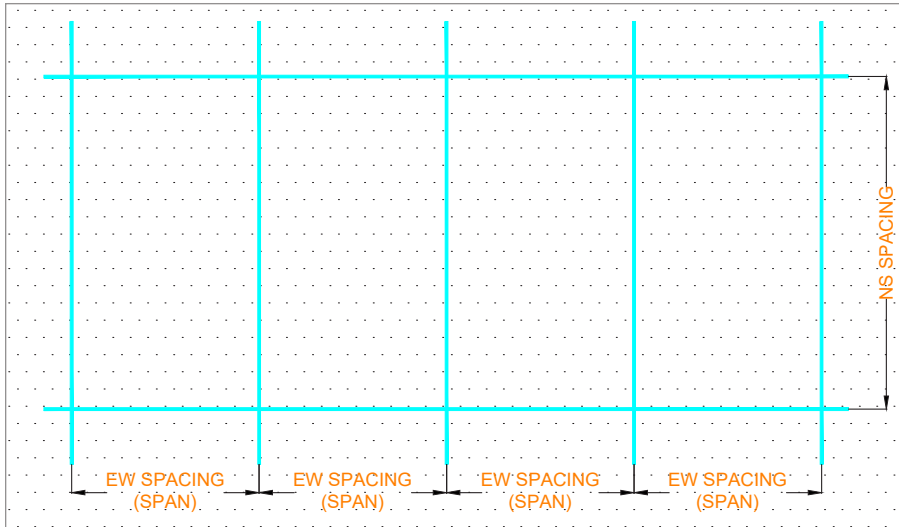

STEP 4. ARRAY LAYOUT

Refer to the calculator tool for details of EW span and NS Spacing. Mark the location for the L-feet.

Span/ Bay: EW distance between two frames. Refer to figure A in page 10 for frame.



STEP 5. DRILL HOLES AND INSTALL CONCRETE ANCHORS

Follow anchor/epoxy manufacturer guidelines for hole depth and diameter. Assure all dust and debris are removed from holes prior to anchor installation. Insert anchors into holes and set per manufacturer's recommendations.

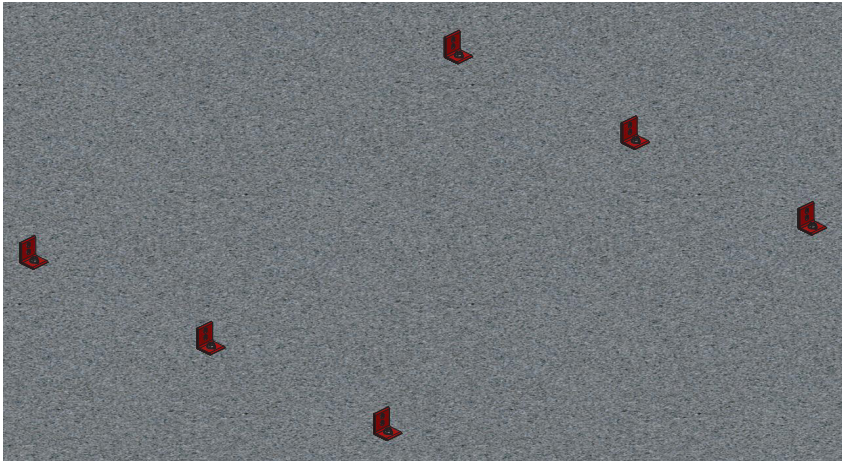

STEP 6. ATTACH SWIVEL L-PLATES TO ANCHORS

Use 3/8" bolt or all-thread with nut, install Swivel L-Plates and secure to concrete anchors. Ensure all Swivel L-Plates are oriented in the same direction. Follow anchor manufacturer requirements for torque specification.



1. Installer need to ensure that the concrete anchor capacity is sufficient.
2. Weak connection may cause failure. Ensure that Swivel L-Plates are securely fastened to the concrete.

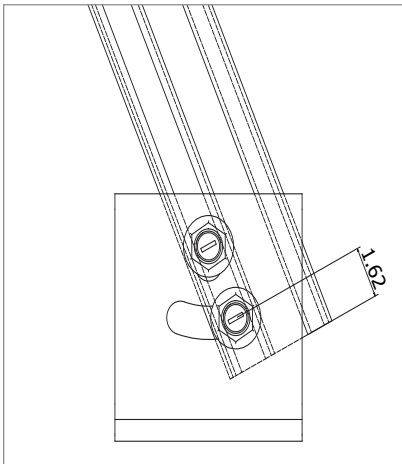

STEP 7. SECURE TILT LEGS TO SWIVEL L-PLATE

Secure tilt legs with two T-bolts by keeping Tilt legs at the required tilt leg angle, see page 5.

Install the first T-Bolt at a distance of 1.62 cm from the face of the rail.

Torque 3/8" nut to 30 ft-lbs

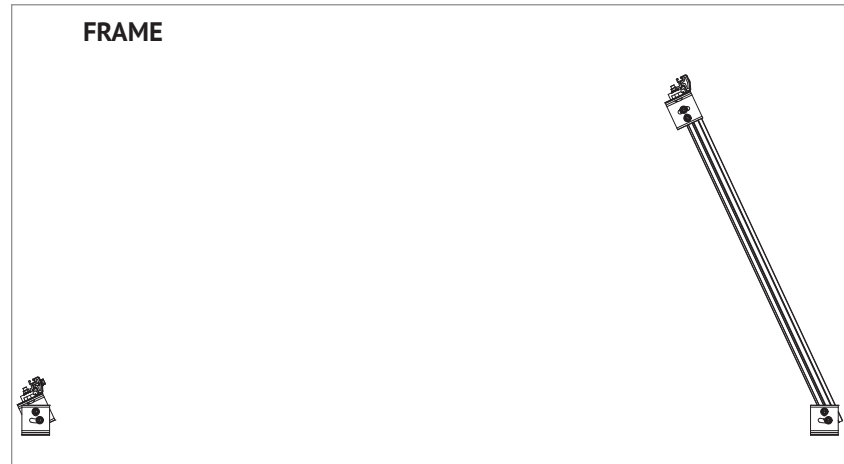
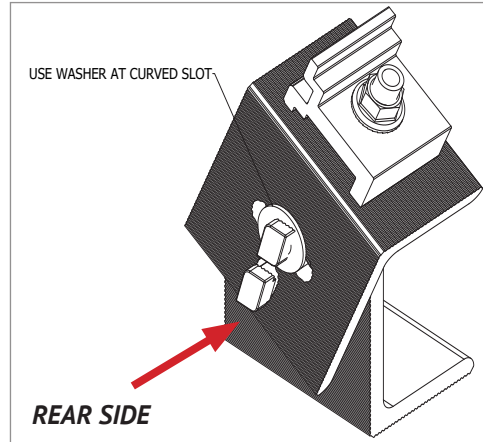
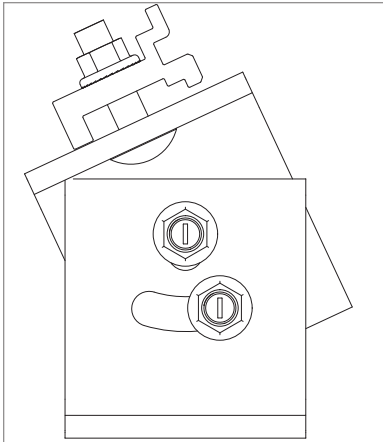

Figure A: Frame - Two-dimensional structural connectivity in the NS direction.



STEP 8. SECURE ALT BEAM CLIP ASSEMBLY TO SWIVEL L-PLATE

Secure the Alt Beam clip Assembly to the Swivel L-Plate using two T-Bolts. Use the washer specified on page 1 to prevent the T-bolt disengagement at the curved slot on the rear side only as shown on image.

Torque 3/8" nut to 30 ft-lbs



STEP 9. INSTALL ALL THE FRAMES

Install the rest of the frames at specified locations in step 4 by repeating steps 7 and 8.

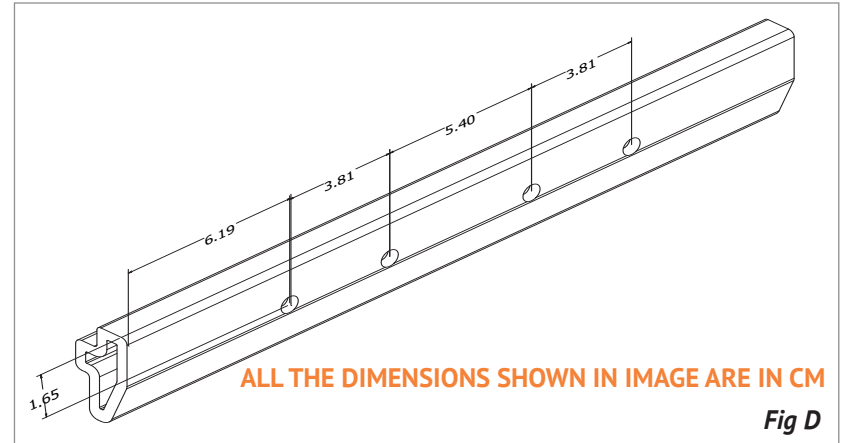
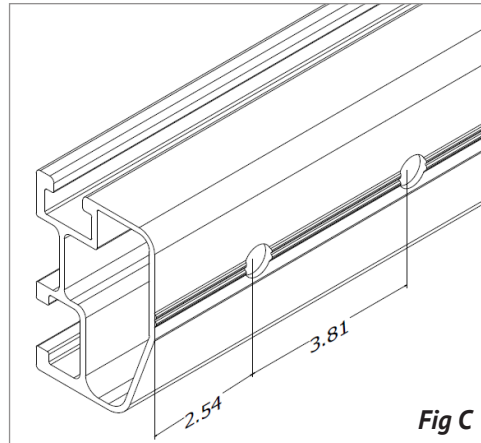
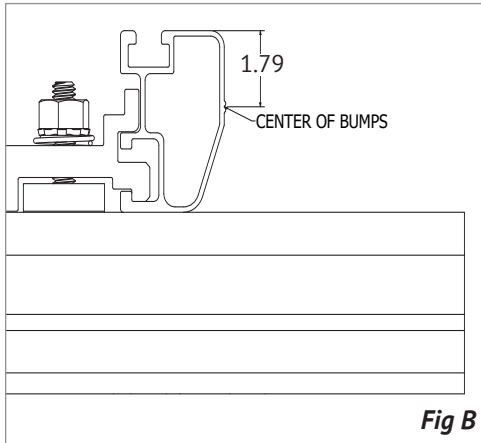

STEP 10. DRILL HOLES ON EAST-WEST (EW) BEAMS & SPLICE MEMBERS

Measure the specified distances on the rails used EW beams as shown on Fig. B&C. Drill pilot holes of 0.238" to allow 5/16" drilling screw.

Measure the specified distances on the side of the splice as shown on Fig. D. Drill pilot holes with the same size drill bits that are used for making holes on EW beams.

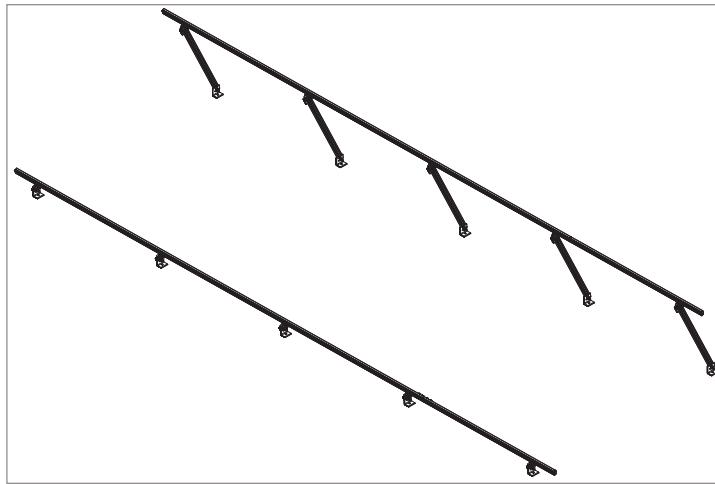
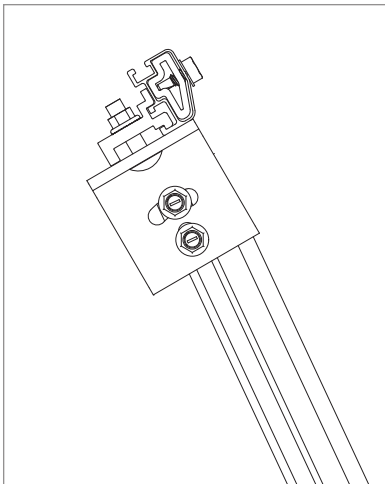

STEP 11. INSTALL EW BEAMS:

Assemble EW beams to the beam clips. Ensure that the desired tilt angle is met. Now torque the Alt beam clip assembly nut which was left loosened in step 2.

Torque 3/8" nut to 15 ft-lbs

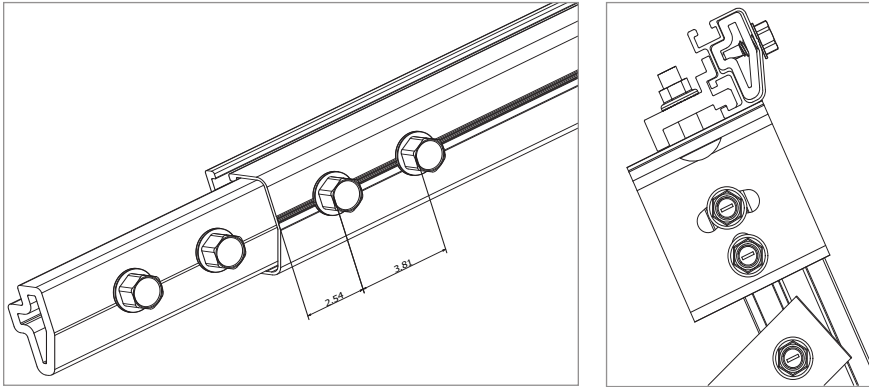

STEP 12. INSTALL SPLICE MEMBERS ON EAST-WEST (EW) BEAMS

Insert the splice into the EW Beam equally on both sides. Ensure that the splice holes and EW beam holes are drilled in the specified distances as mentioned in step 10 and the gap between the spliced EW beams does not exceed 0.32 cm. Failure to do so may result in lowered structural strength.

Use 4 Self-drilling screws, 2 screws on each EW beam on the above figure. Drive the self drilling screws into the holes using impact drill as far as it goes.

Torque 5/16" self drilling screw to minimum 20 ft-lbs.

Note: Ensure when tightening the EW beams that EW spacing at the top of the tilt legs matches the EW spacing at the bottom of the tilt legs, such that the tilt legs will be parallel to each other and vertical.

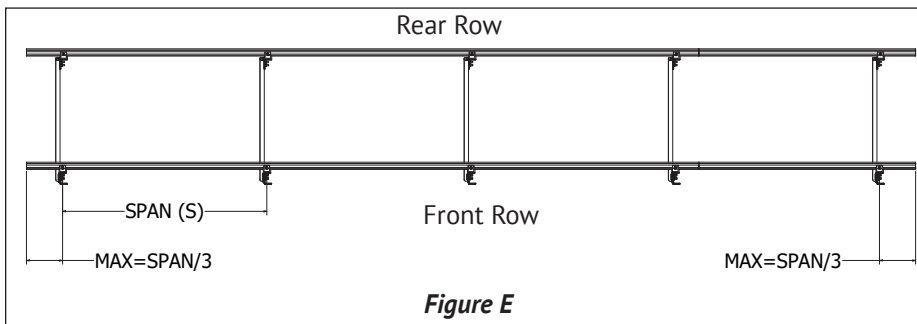
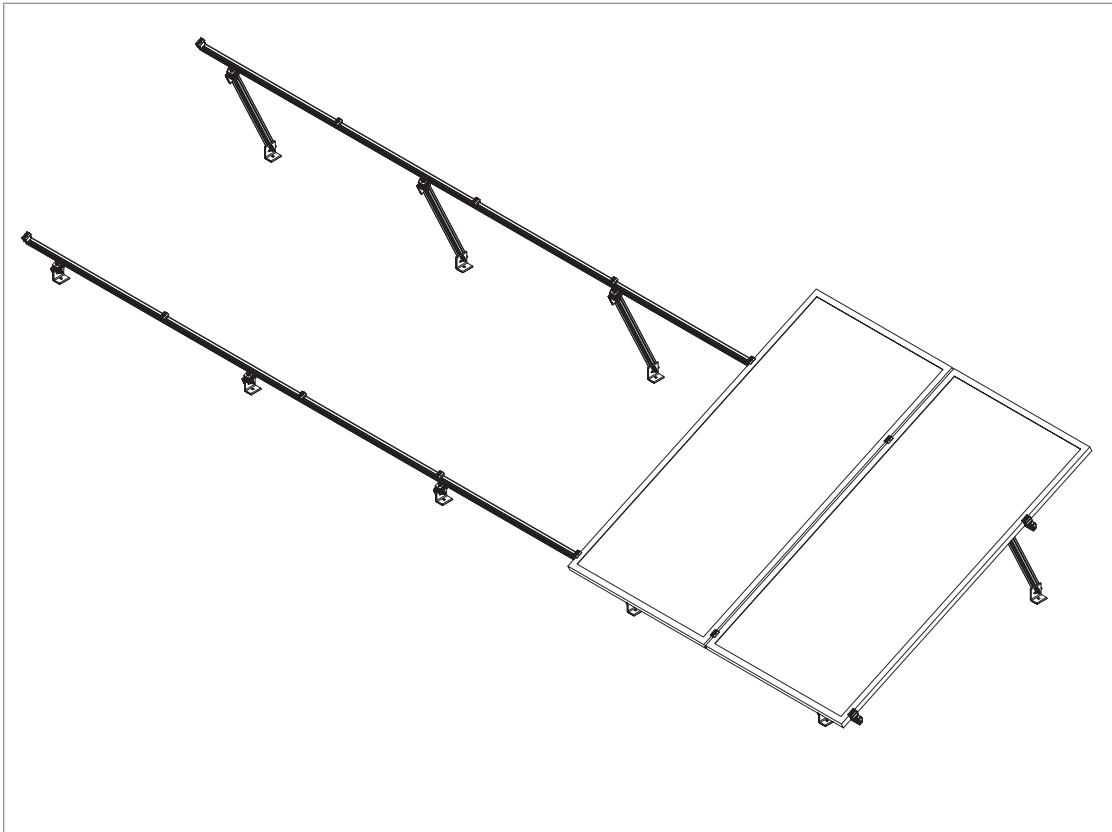

Figure E

STEP 13. CANTILEVER LENGTH LIMIT CHECK

See Fig. E. Maximum length of the cantilever beam should be 1/3rd of the span and minimum cantilever should be 12.7 cm. Refer to the calculator sheet for span chart details.



STEP 14. INSTALL PV MODULES

Using supplied clamps, attach modules to EW beams. Install end-clamp first then continue to use mid-clamps along the array until the final module, then use an end-clamp.

Notes:

1. Ensure roof clearance is not more than 12.7 cm . See page 5.
2. See page 19, Micro Inverter Mounting section for installing MLPEs.

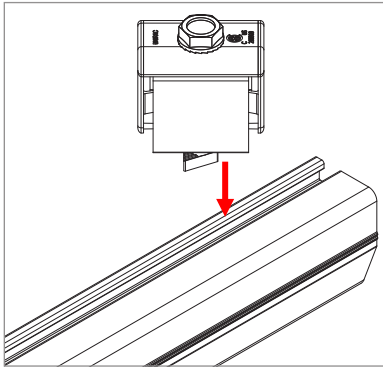

1. Position clamp to align T-bolt with rail slot. Lower clamp and insert T-bolt into rail slot.

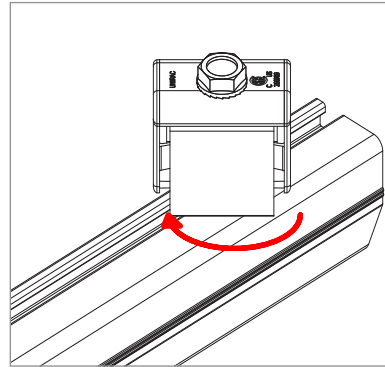

2. Rotate clamp clockwise until the T-bolt fully engages to the inside of the rail slot.

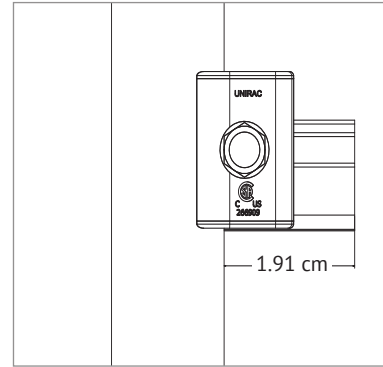

3. Place module at least 1.91 cm from end of rail and position clamp against the module frame.

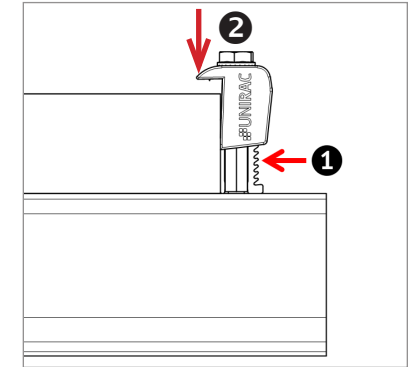

4. While applying pressure to hold the clamp against the module, push down on the module side of the clamp cap.

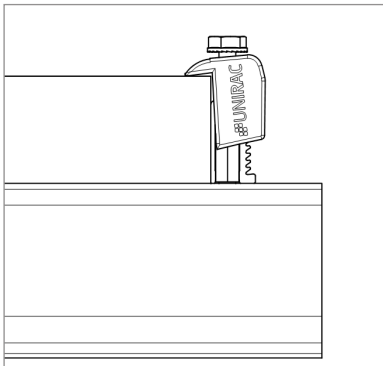

5. When the cap contacts the module frame, release downward pressure and it will re-engage to the clamp base.

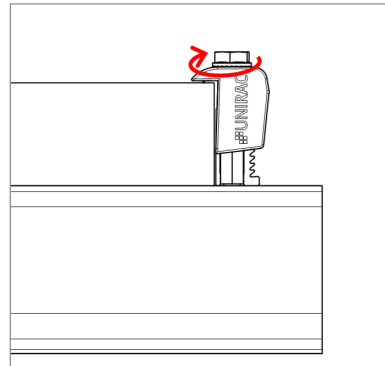

6. Tighten bolt and torque to 15 ft-lbs.

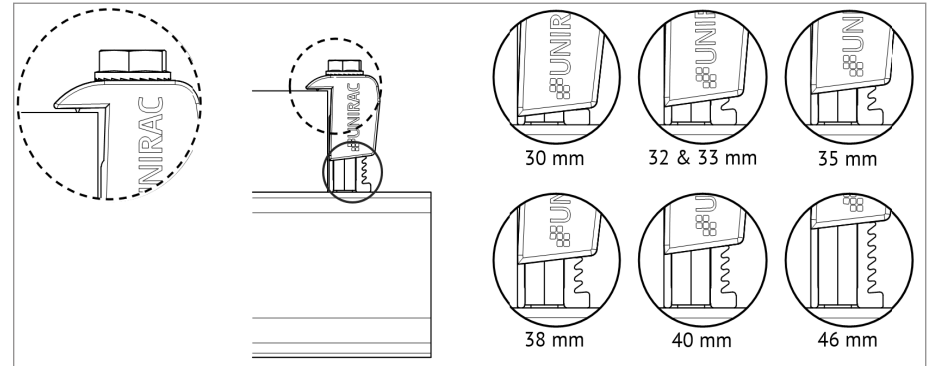

7. Confirm clamp is engaged in correct module height position and that the top of the cap is sitting level with the module frame.

NOTE:

- 1. When installing 46mm modules, loosen bolt by 1 turn before positioning clamp against module frame.
- 2. Do not force clamp onto module frame as this may damage the bonding pin.

NOTE: Clamp is certified for single use only.

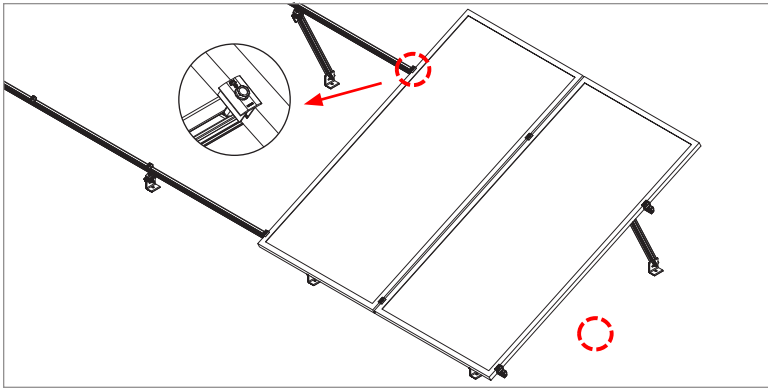

MID CLAMP INSTALLATION

Mid clamp is supplied as an assembly with a T-bolt. Clamp assemblies can be positioned in rail prior to module placement.

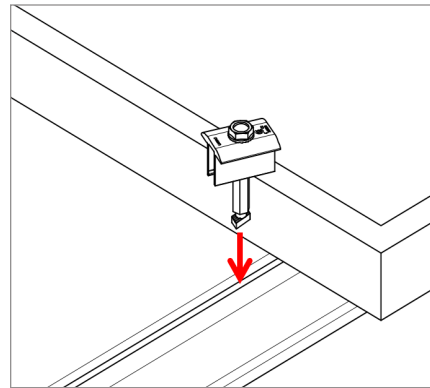

1. Position clamp to align T-bolt with rail slot. Lower clamp and insert T-bolt into rail slot

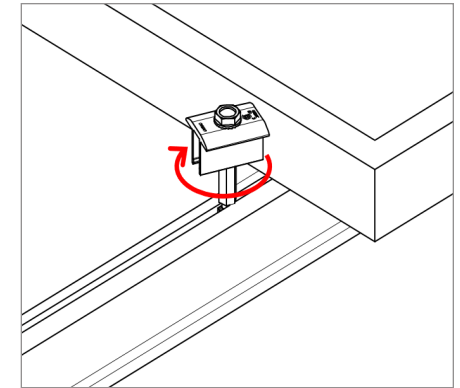

2. Rotate clamp clockwise 63° of a turn to fully engage T-bolt inside rail slot.

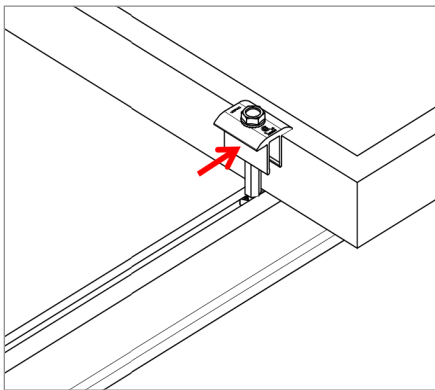

3. Slide clamp into position against module.

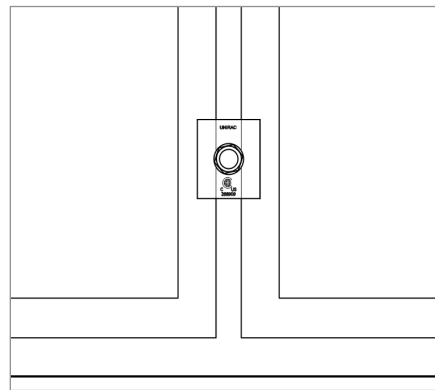

4. Place second module.

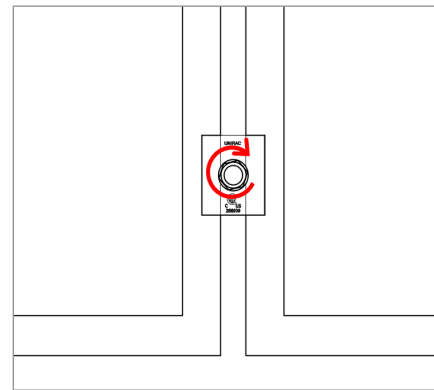

5. Tighten bolt and torque to 15 ft-lbs.

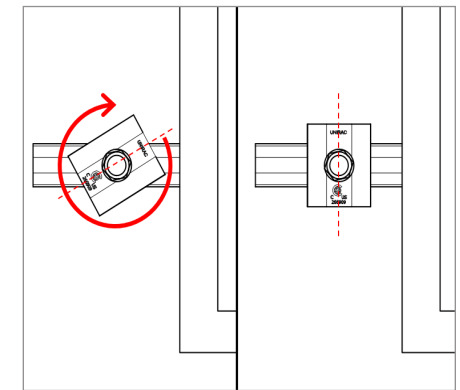

NOTE: If excessive force is applied in step 2, the cap may over-rotate causing it to be mis-aligned with the module frame.

If this occurs, keep rotating the cap clockwise or counter clockwise until it returns to the original position and ensure that T-bolt is engaged in the T-slot.

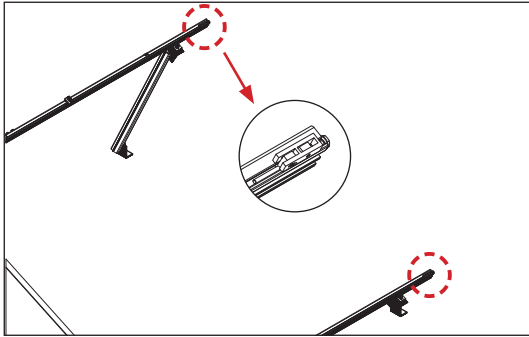

INSTALL MODULE END CLAMPS: The End clamp is supplied as an assembly with a 1/2" hex head bolt that is accessible at the ends of rails. The clamp should be installed on the rails prior to installing end modules.

1

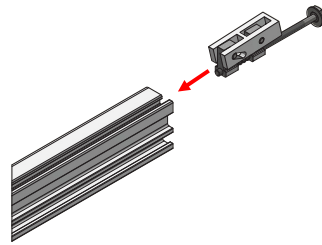

INSTALL END CLAMPS ON RAIL: Slide end clamp on to rail by engaging the two t-guide brackets with the top slot of the rails. Ensure bolt is extended as far as possible so that clamp is positioned at max. distance from end of rail.

2

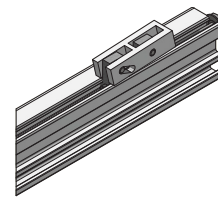

POSITION END CLAMPS: Slide end clamp assembly on to rail until bolt head engages with end of rail. End clamps are positioned on rails prior to the first end module and prior to the last end module.

3

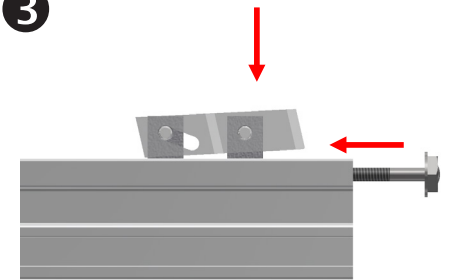

NOTE: To assist insertion of clamp into rail slot, Pressure may be applied to top or side of bracket as shown. Do not force clamp into rail by pushing on bolt with excessive force.

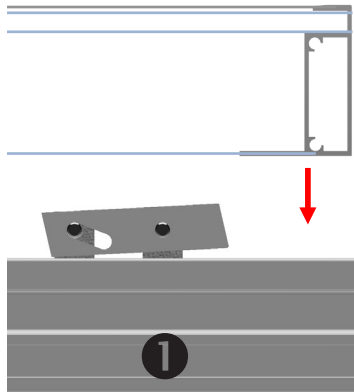

INSTALL FIRST MODULE: Install the first end module onto rails with the flange of the module frame positioned between end clamps at ends of rails.

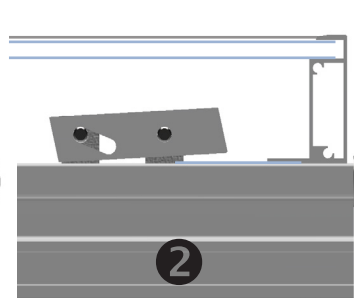

ENGAGE CLAMP: While holding module in position and with flange in full contact with rail, rotate end clamp bolt until clamp engages with flange to provide clamp force.

To ensure bolt is not over-torqued, use low torque setting on drill or If using an impact driver, stop rotation as soon as impact action of driver begins.

Torque End clamp bolt to 5 ft-lbs

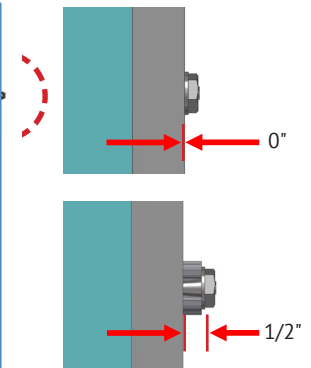
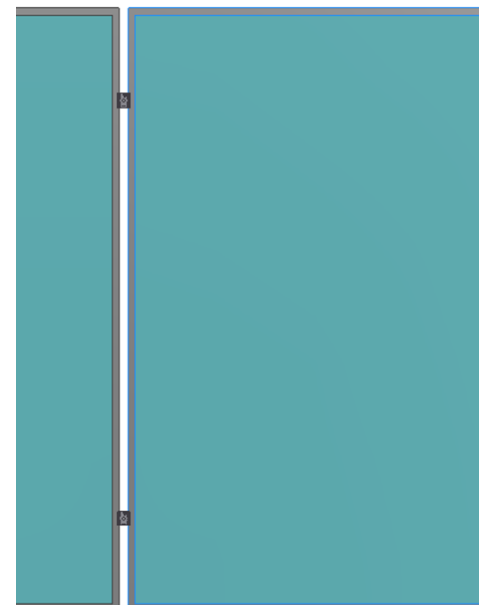
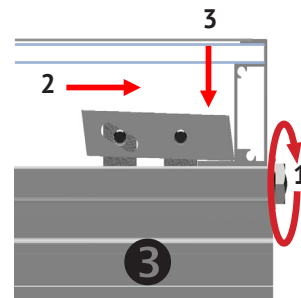

For best appearance, position module flush with ends of rails. Rails should not extend more than 1/2" beyond module. Module must be fully supported by rails and cannot overhang ends of rails.

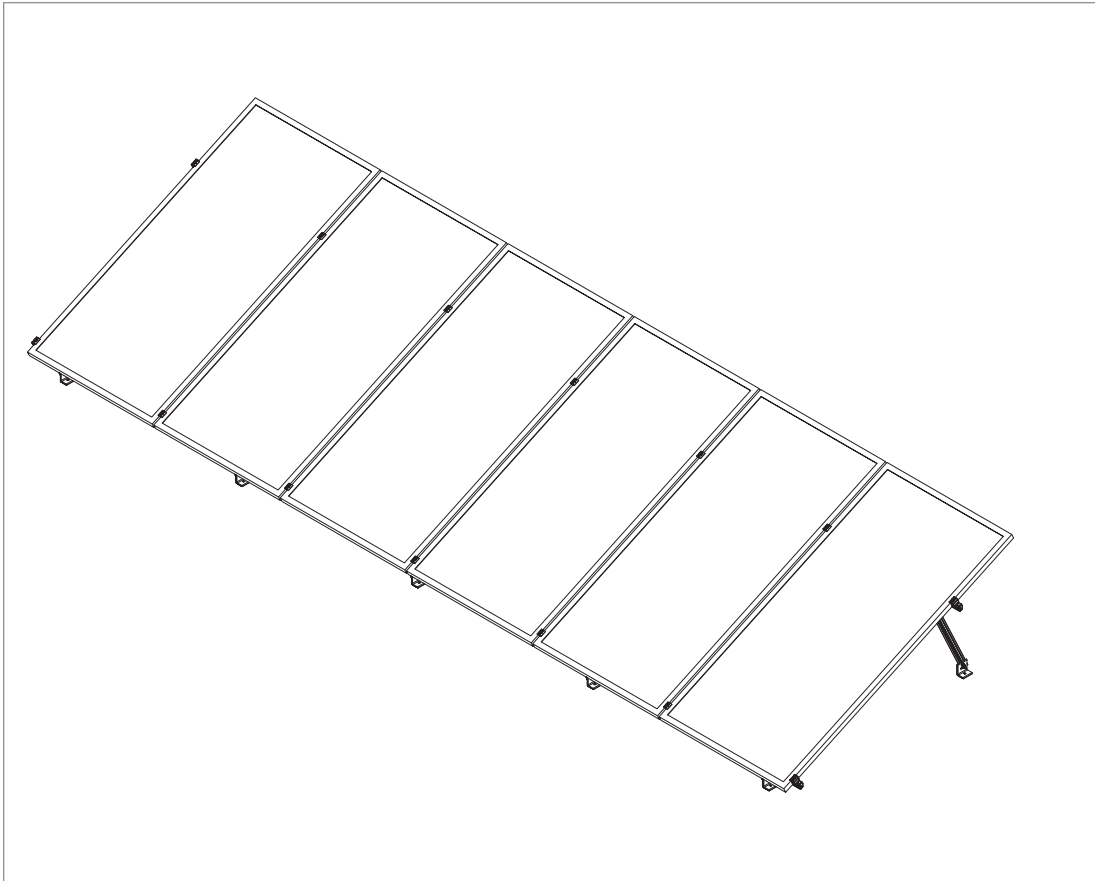

STEP 15. FINAL CHECK

Check all fasteners to verify correct torque values and proper T-bolt engagement with rail.

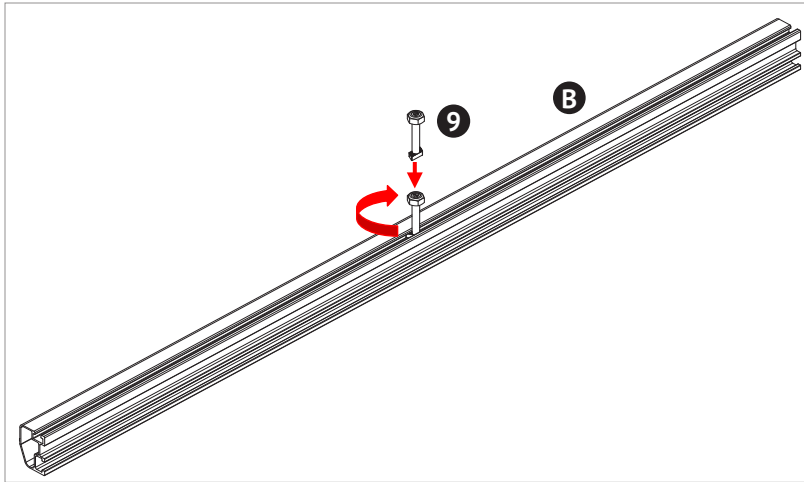

INSTALL MICROINVERTER MOUNT T-BOLT:

Apply Anti-Seize and install pre-assembled 1/4" diameter bonding T-Bolts into top 1/4" rail slot at microinverter locations. Rotate bolts into position.

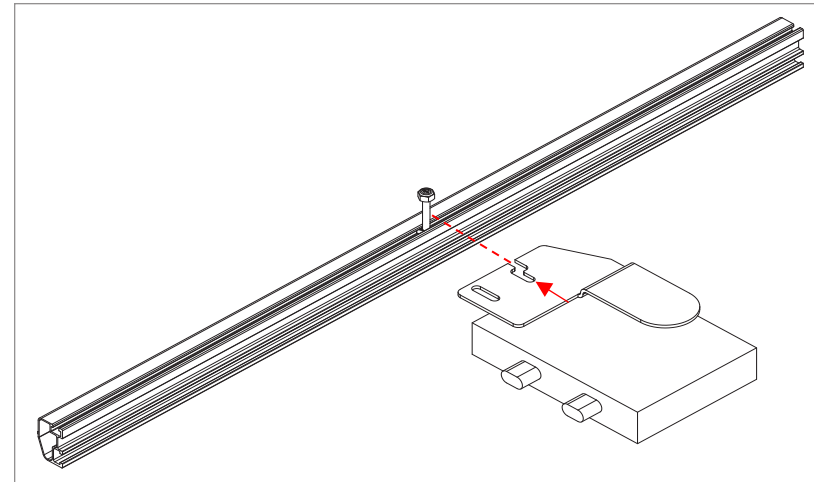

INSTALL MICROINVERTER:

Install microinverter on to the rail. Engage with bolt.

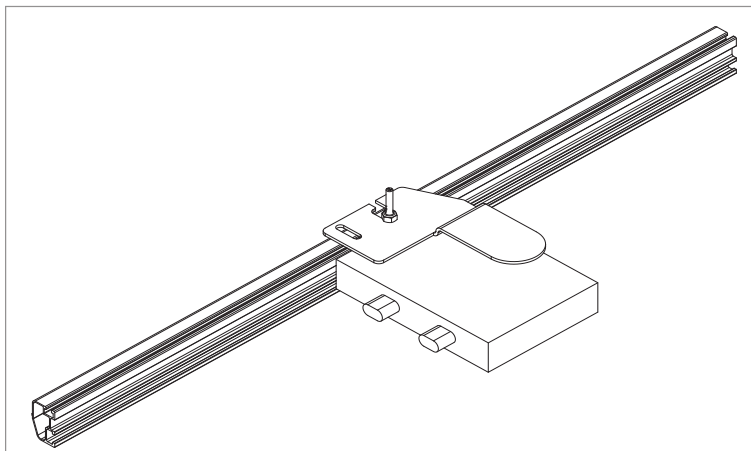

INSTALL MICROINVERTER:

Torque the 1/4" nut to 10 ft-lbs with Anti-Seize.

NOTES:

1. MLPE Mount is certified for single use only.
2. MLPE need to be installed along with module installation.

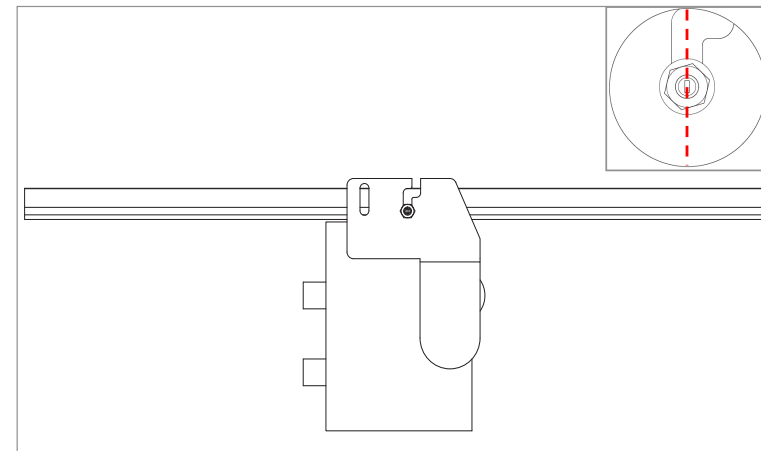

ALIGN POSITION INDICATOR:

Verify that position indicator on the T-bolt is perpendicular to rail.



Only one lug per array of modules is required.

GROUNDING LUG MOUNTING DETAILS:

Below are the details provided for both the WEEB and IlSCO products. The WEEB Lug has a grounding symbol located on the lug assembly. The IlSCO lug has a green colored set screw for grounding indication purposes. Installation must be in accordance with NFPA NEC 70, however the electrical designer of record should refer to the latest revision of NEC for actual grounding conductor cable size.

GROUNDING LUG-BOLT SIZE & DRILL SIZE		
GROUND LUG	BOLT SIZE	DRILL SIZE
WEEB Lug	1/4"	N/A-Place in Top SM Ascender Rail Slot
ILSCO Lug	#10-32	7/32"

- Torque value depends on conductor size.
- See product data sheet for torque value.

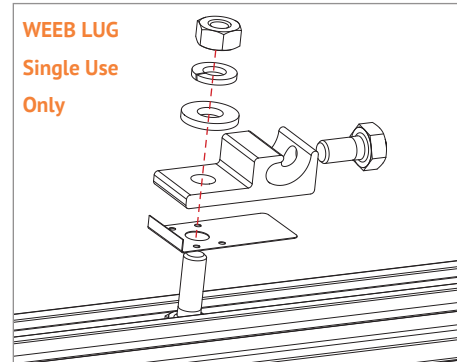

WEEB LUG
Single Use
Only

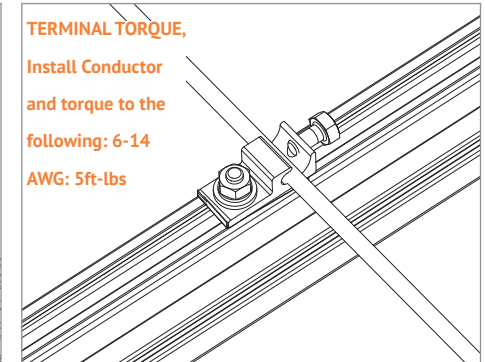

TERMINAL TORQUE,
Install Conductor
and torque to the
following: 6-14
AWG: 5ft-lbs

WEEB LUG CONDUCTOR - UNIRAC P/N 008002S:

Apply Anti Seize and insert a hex bolt in the aluminum rail through the T-slot. Place the stainless-steel flat washer on the bolt, oriented so the dimples will contact the aluminum rail. Place the lug portion on the bolt and stainless-steel flat washer. Install stainless steel flat washer, lock washer and nut. Tighten the nut until the dimples are completely embedded into the rail and lug.

TORQUE VALUE 10 ft lbs.

See product data sheet for more details, Model No. WEEB-LUG-6.7

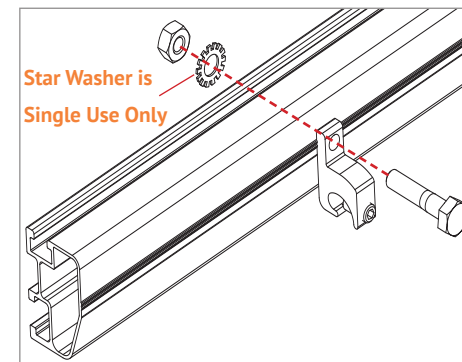

Star Washer is
Single Use Only

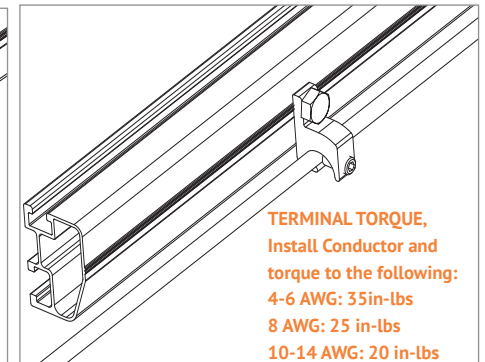

TERMINAL TORQUE,
Install Conductor
and torque to the following:
4-6 AWG: 35in-lbs
8 AWG: 25 in-lbs
10-14 AWG: 20 in-lbs

ILSCO LAY-IN LUG CONDUCTOR - UNIRAC P/N 008009P: Alternate Grounding

Lug- Drill, deburr hole and bolt thru both rail walls per table.

TORQUE VALUE 5 ft lbs.

See ILSCO product data sheet for more details, Model No. GBL-4DBT.

NOTE: ISOLATE COPPER FROM ALUMINUM CONTACT TO PREVENT CORROSION.

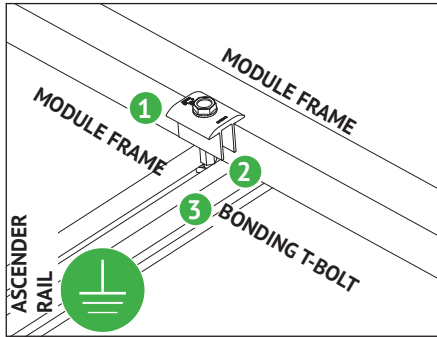

BONDING MIDCLAMP ASSEMBLY

- 1 Aluminum mid clamp with stainless steel bonding pins that pierce module frame anodization to bond module to module through clamp.
- 2 Stainless steel nut bonds aluminum clamp to stainless steel T-bolt.
- 3 Serrated T-bolt head penetrates rail to bond T-bolt, nut, clamp, and modules to SM Ascender rail.

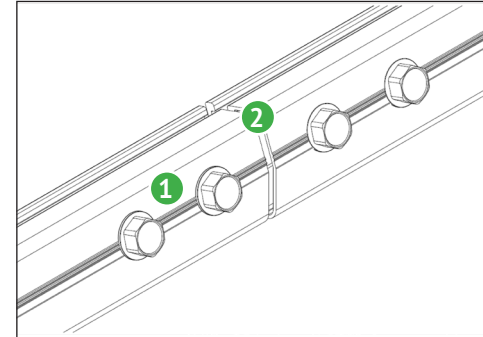
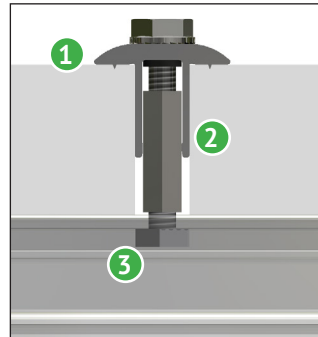

BONDING RAIL SPICE BAR

- 1 5/16" self drilling screw creates bond between splice bar and EW beams.
- 2 Aluminum splice bar spans across rail gap to create rail to rail bond.

Note: Splice bar and bolted connection are structural. The splice bar function is rail alignment, strength and bonding.

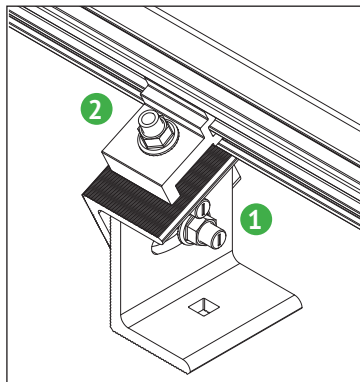

BONDING BEAM CLIP AND Swivel L-Plate

- 1 3/8" T-bolt and 3/8" serrated flange nut with washer creates bond between Swivel L-Plate and Alt beam clip assembly.
- 2 Carriage bolt with 3/8" serrated flange nut creates bond between Swivel L-Plate, Beam clip and E-W beam.

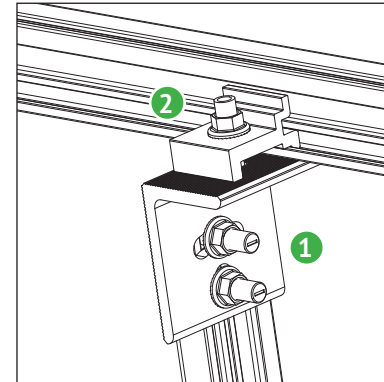

BONDING REAR TILT LEG AND E-W BEAM

- 1 3/8" T-bolt and 3/8" serrated flange nut with washer creates bond between rear tilt leg and alternate beam clip assembly.
- 2 Carriage bolt with 3/8" serrated flange nut creates bond between Swivel L-Plate, Beam clip and E-W beam.

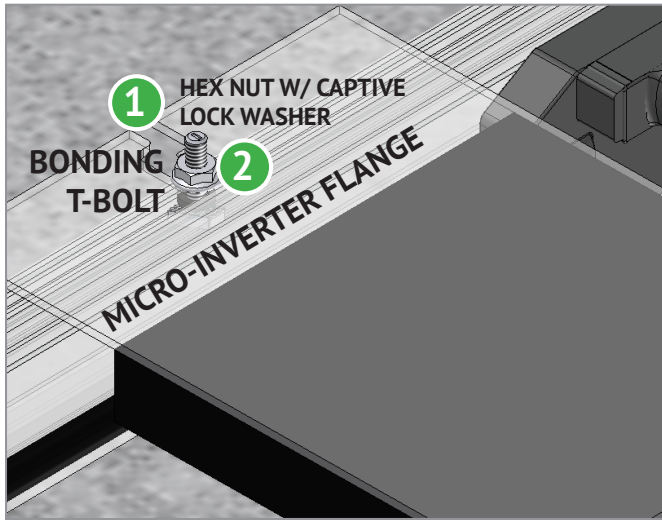

BONDING MICROINVERTER MOUNT

- 1 Hex nut with captive lock washer bonds metal microinverter flange to stainless steel T-bolt.
- 2 Serrated T-bolt head penetrates rail to bond the T-bolt and nut to the grounded Ascender rail.

CAUTION

1. If loose components or loose fasteners are found during periodic inspection, re-tighten immediately.
2. Any components showing signs of corrosion or damage that compromise safety shall be replaced immediately.

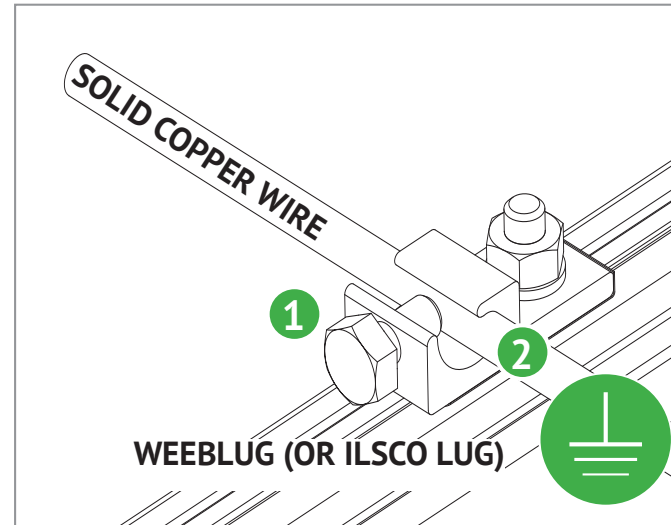

RACK SYSTEM GROUND

- 1 WEEB washer dimples pierce rail to create a bond between rail and lug.
- 2 Solid copper wire connected to lug is routed to provide final system ground connection.

NOTE: IlSCO lug can also be used when secured to the side of the rail.

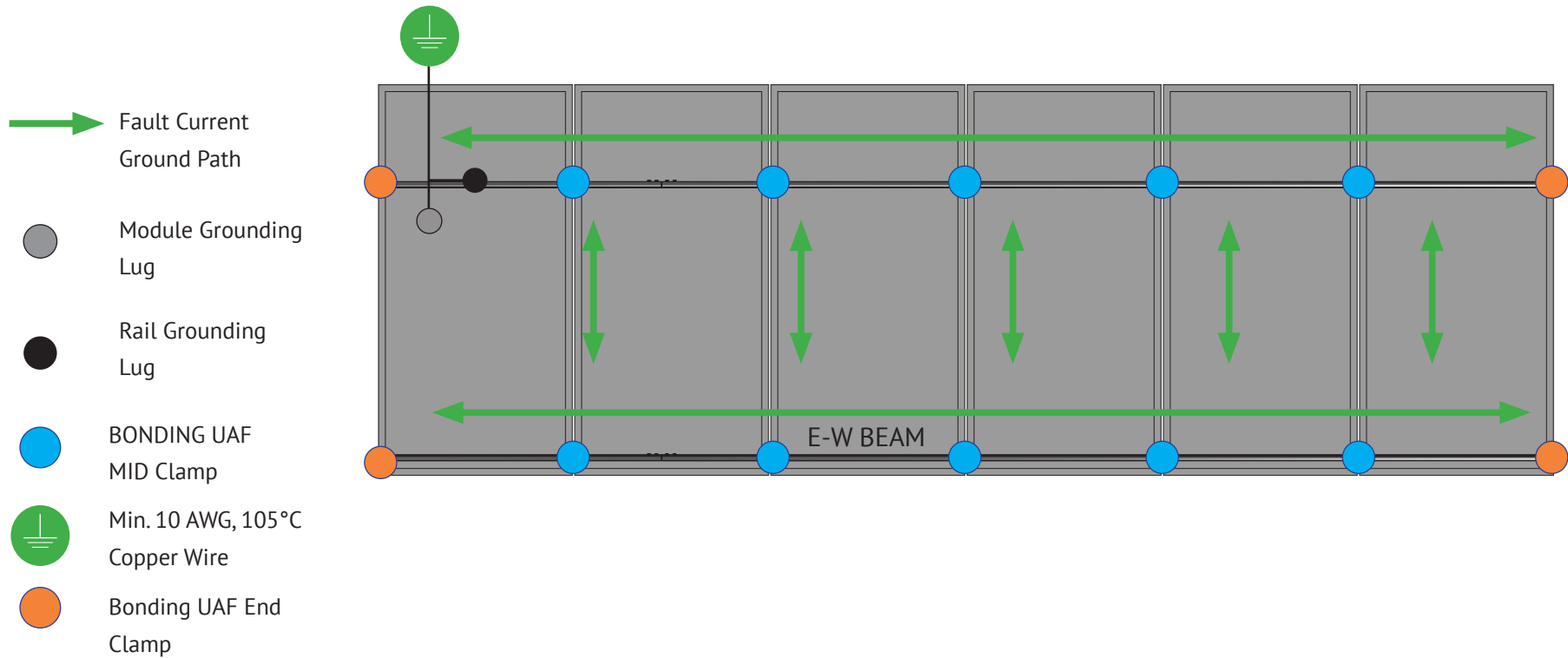

Note: Every array must have atleast one grounding lug; either a module grounding lug or a rail grounding lug.

Refer to page 24 for NS bonding connections.

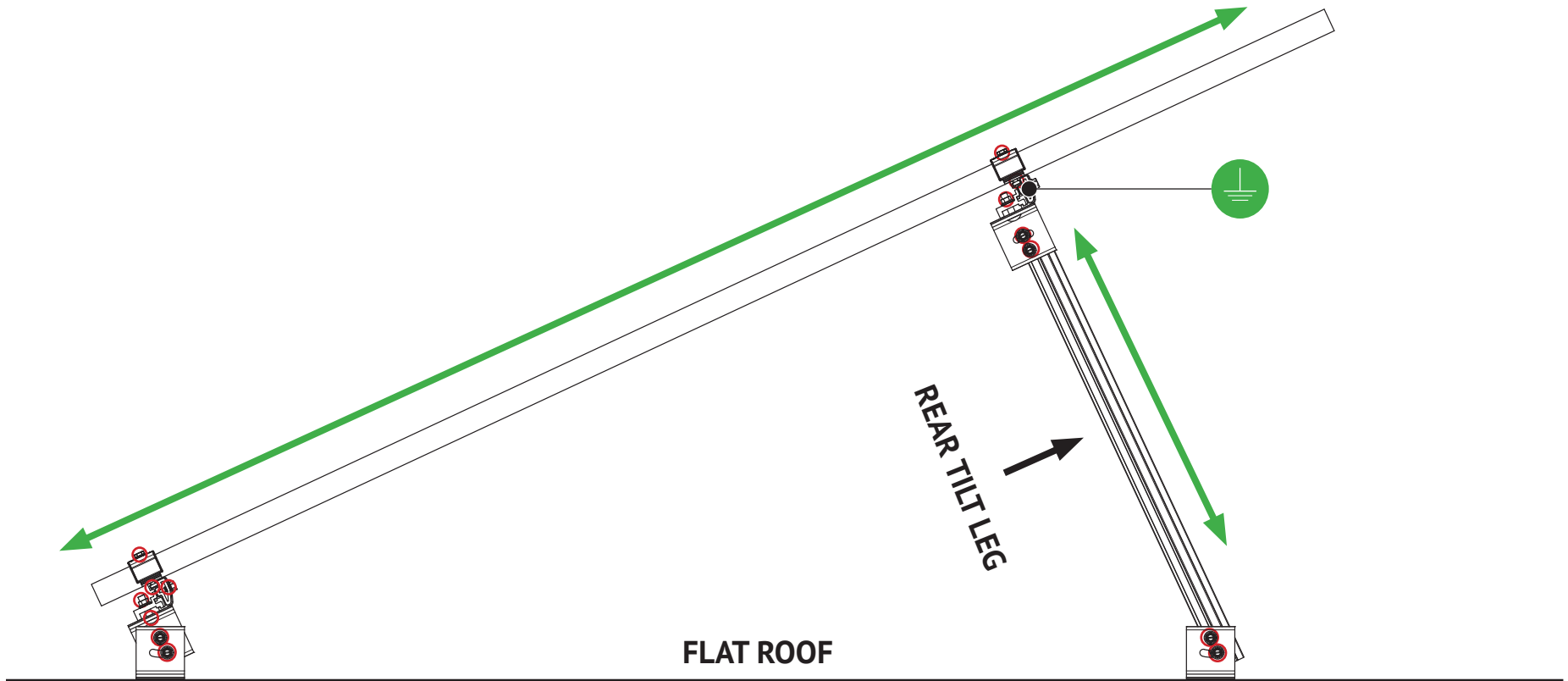

Fault Current Ground Path



Bonding Connection



Min. 10 AWG, 105°C
Copper Wire



Rail Grounding
Lug

This racking system may be used to ground and/or mount a PV module complying with UL1703 or UL61730 only when the specific module has been evaluated for grounding and/or mounting in compliance with the included instructions.

UL2703 CERTIFICATION MARKING

Unirac SM Ascender is listed to UL 2703. Certification marking is embossed on all mid clamps and Universal AF end clamps as shown.

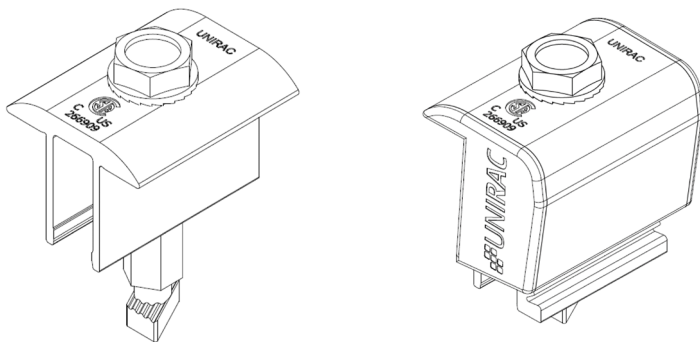

The SM Ascender system has been certified and listed to the UL 2703 standard (Rack Mounting Systems and Clamping Devices for Flat-Plate Photovoltaic Modules and Panels). This standard includes electrical grounding, electrical bonding, mechanical load and fire resistance testing.

In conducting these tests, specific modules are selected for their physical properties so that the certifications can be broadly applied. The following lists the specific modules that were tested and the applicability of those certifications to other modules that might come onto the market. PV modules may have a reduced mechanical load rating, independent of the SM Ascender load rating. Please consult the PV module manufacturer's installation guide for more information.

In addition to UL 2703 certification, Unirac performs internal testing beyond the requirements of certification tests in order to establish system functional limits, allowable loads, and factors of safety. These tests include functional system tests, and destructive load testing.

Mechanical Load Test Modules			
<p>The modules selected for UL 2703 mechanical load testing were selected to represent the broadest range possible for modules on the market. The tests performed cover the following basic module parameters:</p> <ul style="list-style-type: none"> • PV module may have reduced load rating, independent of the SM Ascender rating. Please consult the PV module manufacturer's installation guide for more information. • Frame thicknesses greater than or equal to 1.0 mm. • Basic single and double wall frame profiles (some complex frame profiles could require further analysis to determine applicability). • Clear and dark anodized aluminum frames. 			
Tested Modules			
Module Manufacturer	Model/Series	Area [sqft]	UL2703 Certification Load Ratings
Jinko	JKM M-72HL4-V	27.76	Down: 28.5 PSF, Up: 31.9 PSF Down-Slope: 5.18 PSF



Electrical Bonding and Grounding Test Modules

The list below is not exhaustive of compliant modules but shows those that have been evaluated and found to be electrically compatible with the SM ASCENDER system.

Manufacture	Module Model / Series
Aionrise	AION60G1, AION72G1
Aleo	P-Series & S-Series
Aptos Solar	DNA-108-(MF/BF)10-xxxW DNA-120-(MF/BF)10-xxxW DNA-120-(MF/BF)23 DNA-120-(MF/BF)26 DNA-120-MF10 DNA-144-(MF/BF)23 DNA-144-(MF/BF)26 DNA-144-BF10-xxxW-DG
Astronergy	ASM6612P Series CHSM6612 M, M/HV CHSM6612P/HV Series CHSM6612P Series CHSM72M(DG)/F-BH CHSM72M-HC
Auxin	AXN10Mxxx AXN6M610T AXN6M612T AXN6P610T AXN6P612T AXNG1M Series
Axitec	AC-xxx(M/P)/60S AC-xxx(M/P)/72S AC-xxxMH/120(S/V/SB/VB) AC-xxxMH/144(S/V/SB/VB) AC-xxxP/156-60S AC-xxxTGB/144TS
Bluesun Solar	HEX5 BSMxxxM10-54HPH BSMxxxM10-72HBD

Manufacture	Module Model / Series
Boviet Solar	BVM6610 BVM6610M-xxxS-H-HC BVM6610M-xxxS-H-HC-BF BVM6612 BVM6612M-xxxS-H-HC-BF-DG BVM7612M-H-HC-BF-DG
BYD	P6K & MHK-36 Series
Canadian Solar	CS1(H/K/U/Y)-MS CS3K-(MB/MB-AG/MS/P/P HE/PB-AG) CS3L-(MS/P), CS3N-MS CS3U-(MB/MB-AG/MS/P/P HE/PB/PB-AG) CS3W-(MS/MB-AG/P/P-PB-AG) CS3Y-MB-AG, CS5A-M CS6.1-54TM-H, CS6.1-60TM-H CS6.1-72TB-H CS6.2-66TB-xxxH CS6K-(M/MS/MS AllBlack/P/P HE) CS6P-(M/P) CS6R-MS CS6R-xxxMS-HL CS6U-(M/P/P HE) CS6W-(MS/MB-AG) CS6W-xxx-TB-AG CS6X-P, CSX-P ELPS CS6(A/P)-MM
Centrosolar America	C-Series & E-Series

Manufacture	Module Model / Series
CertainTeed	CT2xxMxx-01, CT2xxPxx-01, CTxxxMxx-01 CTxxxPxx-01, CTxxxMxx-02, CTxxxMxx-03 CTxxxMxx-04, CTxxxHC11-04 CTM10400HC11-08, CTM10400HC11-09 CTM10400HC11-06, CTxxxHC11-06 CTTCxxxHC12-08
Eco Solargy	Orion 1000 & Apollo 1000
EMMVEE	ExxxHCBG144-T ExxxHCBT144-T ExxxHCM120-B ExxxM72-B ExxxP72-B Titanium Clear
Energy America	ZLK-xxx
ET Solar	ET AC Module, ET Module ET-M772BH520-550WW/WB ET-M772BHxxxTW/TB
First Solar	FS-6XXX(A) FS-6XXX(A)-P FS-6XXX(A)-P-I
Flextronics	FXS-xxxBB
Freedom Forever	FF-MP1-BBB-xxx FF-MP-BBB-xxx
FreeVolt	PVGraf
GCL	GCL-P6 & GCL-M6 Series
Hansol	TD-AN3, TD-AN4 UB-AN1, UD-AN1
Hanwha SolarOne	HSL 60

- Unless otherwise noted, all modules listed above include all wattages and specific models within that series. Variable wattages are represented as "xxx"
- Items in parenthesis are those that may or may not be present in a compatible module's model ID
- Slashes "/" between one or more items indicates that either of those items may be the one that is present in a module's model ID
- The frame profile must not have any feature that might interfere with the bonding devices that are integrated into the racking system
- Use with a maximum over current protection device OCPD of 30A



SOLARMOUNT ASCENDER 1-ROW NON ELEVATED

COMPATIBLE MODULES : 28 SYSTEM CERTIFICATION : PAGE

Electrical Bonding and Grounding Test Modules

The list below is not exhaustive of compliant modules but shows those that have been evaluated and found to be electrically compatible with the SM ASCENDER system.

Manufacture	Module Model / Series
Heliene	36M, 36P 60M, 60P, 72M & 72P Series 132HC M10 SL Monofacial Module 144HC M10 SL Bifacial 144HC M6 156HC M10 SL Bifacial
HT-SAAE	HT60-156M-C HT60-156M(V)-C HT72-156(M/P) HT72-156P-C, HT72-156P(V)-C HT72-156M(PDV)-BF, HT72-156M(PD)-BF HT72-166M, HT72-18X
Hyperion Solar	HY-DH108N8B HY-DH108P8(B) HY-DH144P8 HY-DH156N8 HY-DH156P8
Hyundai	KG, MG, RW, TG, RI, RG, TI, KI, HI Series HiA-SxxxHG HiD-SxxxRG(BK) HiN-SxxxXG(BK) HiN-TxxxNF(BK) HiN-TxxxNI HiN-TxxxNJ HiN-TxxxOJ HiS-S400PI HiS-SxxxGI HiS-SxxxOJ HiS-SxxxXG(BK) HiS-SxxxYH(BK) HiS-TxxxNF(BK) HiS-TxxxNJ

Manufacture	Module Model / Series
Illuminate USA	IL5-72HBD-xxx M IL8-66HGD-xxx M
Imperial Star	ISM7-SHDD108-400/M
ITEK	iT-SE Series
Japan Solar	JPS-60 & JPS-72 Series
JA Solar	JAM6(K)-60/xxx, JAP6(k)-72-xxx/4BB JAP72S##-xxx/** JAP6(k)-60-xxx/4BB, JAP60S##-xxx/** JAM6(k)-72-xxx/**, JAM72S##-xxx/** JAM6(k)-60-xxx/**, JAM60S##-xxx/** i. ##: 01, 02, 03, 09, 10 ii. **: SC, PR, BP, HiT, IB, MW, MR ** = Backsheet, ## Cell technology JAM54D41-xxx/MB JAM54S30 xxx/MR JAM54S31 xxx/MR JAM66D45 LB JAM72D10 xxx/MB JAM72D30MB JAM72D40 xxx/MB JAM72S30 /MR JAM78D10MB JAP6 60-xxx
Jinko	JKM & JKMS Series JKMxxxM-6RL3-B JKMxxxM-72HBL-V JKMxxxM-72HL4-(T)V JKMxxxM-72HL4-TV

Manufacture	Module Model / Series
Jinko (Cont.)	JKMxxxM-72HLM-TV JKMxxxM-72HL-V JKMxxxM-7RL3-TV JKMxxxM-7RL3-V JKMxxxN-54HL4-B JKMxxxN-72HL4-BDV JKMxxxN-72HL4-BDX JKMxxxN-72HL4-TV
Kyocera	KD-F & KU Series
LA Solar	BLA Model LSxxxBF LSxxxBL LSxxxBL (410 watt) LSxxxHC LSxxxHC(166) LSxxxHC (430-450 watt range)
LG Electronics	LGxxx(E1C/E1K/N1C/N1K/N2T/N2W/S1C/ S2W/Q1C/Q1K)-A5 LGxxx(A1C/M1C/M1K/N1C/N1K/Q1C/Q1K/ QAC/QAK)-A6, LGxxxN2W-B3 LGxxxN2T-B5, LGxxxN1K-B6 LGxxx(N1C/N1K/N2T/N2W)-E6 LGxxx(N1C/N1K/N2W/S1C/S2W)-G4 LGxxxN2T-J5, LGxxx(N1K/N1W/N2T/ N2W)-L5 LGxxx(M1C/N1C/Q1C/Q1K)-N5 LGxxx(N1C/N1K/N2W/Q1C/Q1K)-V5 LGxxxN3K-V6

- Unless otherwise noted, all modules listed above include all wattages and specific models within that series. Variable wattages are represented as "xxx"
- Items in parenthesis are those that may or may not be present in a compatible module's model ID
- Slashes "/" between one or more items indicates that either of those items may be the one that is present in a module's model ID
- The frame profile must not have any feature that might interfere with the bonding devices that are integrated into the racking system
- Use with a maximum over current protection device OCPD of 30A



Electrical Bonding and Grounding Test Modules

The list below is not exhaustive of compliant modules but shows those that have been evaluated and found to be electrically compatible with the SM ASCENDER system.

Manufacture	Module Model / Series
LONGi	LR4-60(HPB/HPH)
	LR4-72(HPH)
	LR4-72HBD xxxM
	LR5-54HABB-xxx M (fire type 29 only)
	LR5-54HPB-xxx M
	LR5-54HTB xxxM
	LR5-72HBD xxx M
	LR6-60
	LR6-60(BK/HPB/HPH/HV/PB/PE/PH)
	LR6-72
	LR6-72(BK/HV/PB/PE/PH)
	LR7-72HGD-xxx M
	LR8-54HGBB
	LR8-66HGD-xxx M
	RealBlack LR4-60HPB
RealBlack LR6-60HPB	
Maxeon	SPR-MAX3-xxx-COM
	SPR-MAX3-XXX-R
	SPR-MAX3-XXX-BLK-R
	SPR-MAX6-xxx
	SPR-MAX6-xxx-BLK
Meyer Burger	Meyer Burger Black
	Meyer Burger White
	Meyer Burger Glass
Mission Solar Energy	MSE Mono, MSE Perc
	MSExxx(SR8T/SR8K/SR9S/SX5T)
	MSExxx(SX5K/SX6W)
	MSExxxHT0B
	MSExxxSX6Z
	MSExxxSX9R

Manufacture	Module Model / Series
Mission Solar Energy (Cont.)	MSH10-xxxHN4G
	MSH10-xxxHT4T
	MSI10-xxxHN4G
	MSI10-xxxHT4G
	MSI10-xxxHT4T
	MSN10xxxHT4T
MSX10-xxxHNOB	
Mitrex	Mxxx-L3H, Mxxx-I3H
Mitsubishi	MJE & MLE Series
mSolar	108BB HC Series (TXI10-xxx108BB)
	144BB HC Series (TXS6-xxx144BB)
Neo Solar Power Co.	D6M Series
NE Solar	NESE xxx-72MHB-M10
	NESE xxx-60MH-M6
	NESE xxx 72MHT-M10
	NESE xxx 72THB-M10
	NESE xxx 72MHB-M10
Panasonic	VBHNxxxSA06/SA06B/SA11/SA11B
	VBHNxxxSA15/SA15B/SA16/SA16B,
	VBHNxxxKA, VBHNxxxKA03/04,
	VBHNxxxSA17/SA17G/SA17E/SA18/SA18E,
	VBHNxxxZA01/ZA02/ZA03/VBHNxxxZA04
	EVPVxxx
Peimar	SGxxxM (FB/BF)
	SMxxxM
Philadelphia Solar	PS-M108(HCBF)-400W (30 & 35mm frames)
	PS-M144(HCBF)-xxxW
	PS-MNB108(HCBF)-xxxW

Manufacture	Module Model / Series
Philadelphia Solar (Cont.)	PS-MNB144(HCBF)-xxxW PS-MNB156(HCBF)-xxxW
Phono Solar	PSxxxM1-20/U
	PSxxxM1H-20/U
	PSxxxM1-20UH
	PSxxxM1H-20UH
	PSxxxM4(H)-24/TH
	PSxxxM1-20/UH
Prism Solar	PSxxxM1H-20/UH
	PSxxxM-24/T
	PSxxxMH-24/T
	PSxxxM-24/TH
	PSxxxMH-24/TH
Q Cells	P72 Series, P72X-xxx
	Peak G5(SC) , G6(+)(SC)(AC), G7, G8(+), Plus, Pro
	Peak L-G2, L-G4, L-G5
	Peak L-G5, L-G6, L-G7, L-G8(BFF)
	Plus, Pro, Peak, G3, G4,
	Q.PEAK DUO(BLK)-G6+
	Q.PEAK DUO (BLK)-G7
	Q.PEAK DUO (BLK) G8(+)
	Q.PEAK DUO (BLK) ML-G10(a)(+)
	Q.PEAK DUO (BLK) ML-G9(+)
	Q.PEAK DUO BLK G10(+)
	Q.PEAK DUO BLK G10+ /AC
	Q.PEAK DUO BLK-G6+/TS
	Q.PEAK DUO BLK ML-G10.B+
	Q.PEAK DUO BLK ML-G10.C+
Q.PEAK DUO BLK ML-G10+ / t	
Q.PEAK DUO BLK ML-G10+ / TS	

- Unless otherwise noted, all modules listed above include all wattages and specific models within that series. Variable wattages are represented as "xxx"
- Items in parenthesis are those that may or may not be present in a compatible module's model ID
- Slashes "/" between one or more items indicates that either of those items may be the one that is present in a module's model ID
- The frame profile must not have any feature that might interfere with the bonding devices that are integrated into the racking system
- Use with a maximum over current protection device OCPD of 30A



SOLARMOUNT ASCENDER 1-ROW NON ELEVATED

COMPATIBLE MODULES : 30 SYSTEM CERTIFICATION : PAGE

Electrical Bonding and Grounding Test Modules

The list below is not exhaustive of compliant modules but shows those that have been evaluated and found to be electrically compatible with the SM ASCENDER system.

Manufacture	Module Model / Series
Q Cells (Cont.)	Q.PEAK DUO-G10+
	Q.PEAK DUO L-(G7/G7.1/G7.2/G7.3/G7.7)
	Q.PEAK DUO L-(G8/G8.1/G8.2/G8.3)
	Q.PEAK DUO L-G6.3 / BFG
	Q.PEAK DUO L-G8.3 (BFF/BFG/BGT)
	Q.PEAK DUO XL-(G10/G10.2/G10.3/G10.c/G10.d)
	Q.PEAK DUO XL-(G11.2/G11.3)
	Q.PEAK DUO XL-(G9/G9.2/G9.3)
	Q.PEAK DUO XL-G10.3/BFG
	Q.PEAK DUO XL-G10.d/BFG
	Q.PEAK DUO XL-G11.3/BFG
	Q.PEAK DUO XL-G11S.3 / BFG
	Q.PEAK DUO XL-G9.3/BFG
	Q.PEAK DUO G10.C1+ AC
	Q.TRON BLK M-G2+
	Q.TRON BLK M-G2+ AC
	Q.TRON BLK M-G2.C+
	Q.TRON BLK M-G2.F+
	Q.TRON BLK M-G2.F1+/AC
	Q.TRON BLK M-G2.H+
	Q.TRON BLK M-G2.H1+/AC.
	Q.TRON BLK M-G2+ SERIES
	Q.TRON M-G2+ SERIES
Q.TRON XL-G2.3/BFG	
Q.PEAK DUO BLK ML-G10.XY+/AC (where "X" = any letter between A to W, where "Y" = any number between 1 to 9.)	

Manufacture	Module Model / Series
REC	RECxxxAA (BLK/Pure/Pure-R/ Pure-RX/ Pure 2/ Pro M) RECxxxNP (N-PEAK) RECxxxNP2 (Black) RECxxxNP3 Black RECxxxPE, RECxxxPE72 RECxxxTP, RECxxxTP72 RECxxxTP2(M/BLK2) RECxxxTP2S(M)72 RECxxxTP3M (Black) RECxxxTP4 (Black)
Renesola	All 60-cell modules RS6-xxxNBG-E3
Risen	RSM Series RSM110-8-xxxBMDG
SEG Solar	SEG-xxx-BMD-HV SEG-xxx-BMD-TB SEG-xxx-BMB-TB SEG-xxx-BMA-HV SEG-xxx-BMA-TB SEG-xxx-BMB-HV SEG-xxx-BMA-BG SEG-xxx-BMB-BG SEG-xxx-BTA-BG SEG-xxx-BTB-BG SEG-xxx-BMD-BG SEG-xxx-BTD-BG
S-Energy	SN72 & SN60 Series SL45-60BG/BHI SL45-60MBI-xxxZ

Manufacture	Module Model / Series
Seraphim	SEG-(6PA/6PB/6MA/6MA-HV/6MB/E01/ E11) SRP-(6QA/6QB) SRP-xxx-BMB-HV SRP-xxx-BMD-HV SRP-xxx-BMA-HV SRP-xxx-BMB-HV SRP-xxx-BMC-HV SRP-xxx-BMZ-HV SRP-xxx-BTA-BG SRP-xxx-BTB-BG SRP-xxx-BTC-BG SRP-xxx-BTD-BG SRP-xxx-BTE-BG
Sharp	NU-SA & NU-SC Series
Silfab	SLA-M, SLA-P, SLG-M, SLG-P & BC Series SIL-xxx(BG/BK/BL/HC/HC+/HL/HM/HN/ML/ NL/NT/NX/NU/ QD/QM) SIL-xxx XL SIL-xxx XM SIL-xxx XM+
Sirius	ELNSM54M-HC-BF Series ELNSM54M-HC Series ELNSM72M-HC Series
Solar4America	S4Axxx-108MH10BB, S4Axxx-72MH5BB S4Axxx-144MH10xxx, S4Axxx-144TH10xxx S4Axxx-144TH16xxx, S4Axxx-108MH10xxx S4Axxx-108TH10xxx

- Unless otherwise noted, all modules listed above include all wattages and specific models within that series. Variable wattages are represented as "xxx"
- Items in parenthesis are those that may or may not be present in a compatible module's model ID
- Slashes "/" between one or more items indicates that either of those items may be the one that is present in a module's model ID
- The frame profile must not have any feature that might interfere with the bonding devices that are integrated into the racking system
- Use with a maximum over current protection device OCPD of 30A



SOLARMOUNT ASCENDER 1-ROW NON ELEVATED

COMPATIBLE MODULES : 31 SYSTEM CERTIFICATION : PAGE

Electrical Bonding and Grounding Test Modules

The list below is not exhaustive of compliant modules but shows those that have been evaluated and found to be electrically compatible with the SM ASCENDER system.

Manufacture	Module Model / Series
SolarEver USA	SE-166*83-xxxM-120N SE-182*91-xxxM-108N SE-182*105-xxxM-96-BD
Solaria	PowerXT-xxxR-(AC/PD/BD) PowerXT-xxxC-PD PowerXT-xxxR-PM (AC) PowerX-400R
Solartech	STU HJT, STU PERC & Quantum PERC
SolarWorld	Sunmodule Protect, Sunmodule Plus/Pro
Sonali	SS-M-360 to 390 Series SS-M-390 to 400 Series SS-M-440 to 460 Series SS-M-430 to 460 BiFacial Series
Sun Edison	F-Series, R-Series
Suniva	MV Series & Optimus Series (35mm)
Sunmac Solar	M7545H-BB Series
SunPower	AC, X-Series, E-Series & P-Series SPR E20 435 COM (G4 Frame) Axxx-BLK-G-AC, SPR-Mxxx-H-AC SPR-Mxxx-H-AC SPR-Mxxx-BLK-H-AC
SunPro	SPDGxxx-120M12
SunTech	STP, STPXXXS - B60/Wnhb
Talesun	TP572, TP596, TP654, TP660 TP672, Hipor M, Smart, TD6I72M TD7G72M TM3G48M TM3G54M

Manufacture	Module Model / Series
Talesun (Cont.)	TM3G66M TM7G54M TM7G60M TM7G72M TP6F72M TP6F72M(H) TP7G54M(H)
Tesla	SC, SC B, SC B1, SC B2 TxxxS TxxxH
Thornova	TS-BBT54(XXX) TS-BG54 TS-BG72 TS-BGT72(XXX)
Trina	DE06, DE09.05, DE09C.07 DEG15HC.20(II), DEG15MC.20(II) DEG15VC.20(II), DE18M(II), DEG18MC.20(II) DE19, DEG19C.20, TSM-NE09RC.05 PA05, PD05, DD05, DD06 PD14, PE14, DD14, DE14, DE15, DE15V(II) TSM-DE09.08, TSM-DE09C.07, TSM- DE09.05 TSM-NEG19RC.20 TSM-DE06X.05(II) TSM-NE09RH.05 TSM-NE19RC
TSMC	TS-150C2 CIGSw
Universal Solar	UNI4xx-144BMH-DG UNI5xx-144BMH-DG UNIxxx-108M-BB

Manufacture	Module Model / Series
Universal Solar (Cont.)	UNIxxx-120M-BB UNIxxx-120MH
Upsolar	UP-MxxxP, UP-MxxxM(-B)
URECO	D7Kxxx(H7A/H8A), D7Mxxx(H7A/H8A) F6MxxxE7G-BB FAKxxx(C8G/E8G) FAMxxxE7G-BB FAMxxxE8G(-BB) FBKxxxM8G FBMxxxM7G-BB FBMxxxMFG-BB
Vikram Solar	Eldora, Somera, Ultima PREXOS VSM DHT.60.AAA.05 PREXOS VSM DHT.72.AAA.05 Paradea VSM DH.72.AAA.05
Vina	VNS-72M1-5-xxxW-1.5 VNS-72M3-5-xxxW-1.5 VNS-144M1-5-xxxW-1.5 VNS-144M3-5-xxxW-1.5 VNS-120M3-5-xxxW-1.0
VSUN	VSUN4xx-144BMH VSUN4xx-144BMH-DG VSUN5xx-144BMH-DG VSUNxxx-108BMH VSUNxxx-108M-BB VSUNxxx-108MH VSUNxxx-120BMH VSUNxxx-120M-BB VSUNxxx-132BMH VSUNxxx-144M-BB

- Unless otherwise noted, all modules listed above include all wattages and specific models within that series. Variable wattages are represented as "xxx"
- Items in parenthesis are those that may or may not be present in a compatible module's model ID
- Slashes "/" between one or more items indicates that either of those items may be the one that is present in a module's model ID
- The frame profile must not have any feature that might interfere with the bonding devices that are integrated into the racking system
- Use with a maximum over current protection device OCPD of 30A

Electrical Bonding and Grounding Test Modules

The list below is not exhaustive of compliant modules but shows those that have been evaluated and found to be electrically compatible with the SM ASCENDER system.

Manufacture	Module Model / Series
VSUN (Cont.)	VSUNxxx-60M-BB VSUNxxx-72MH VSUNxxxN-108BMH-BB VSUNxxxN-108BMH-BB (SoftPaw) VSUNxxxN-120BMH-BB (SoftPaw) VSUNxxxN-144BMH VSUNxxxN-144MH VSUNxxx-144BMH VSUNxxx-144MH VSUNxxx-144M-BW
Waaree	Ahnay Series Bi-33 Arka Series WSMDi
Winaico	WST & WSP Series
Yingli	YGE & YLM Series
Yotta Energy	YSM-B450-1
ZNShine	ZXM6-72 Series, ZXM6-NH144 ZXM6-NH120 Series ZXM6-NHLDD144 ZXM7-SH108 Series ZXM7-SHDB144 ZXM7-SHLDD144 ZXM7-UHLDD144

- Unless otherwise noted, all modules listed above include all wattages and specific models within that series. Variable wattages are represented as "xxx"
- Items in parenthesis are those that may or may not be present in a compatible module's model ID
- Slashes "/" between one or more items indicates that either of those items may be the one that is present in a module's model ID
- The frame profile must not have any feature that might interfere with the bonding devices that are integrated into the racking system
- Use with a maximum over current protection device OCPD of 30A