

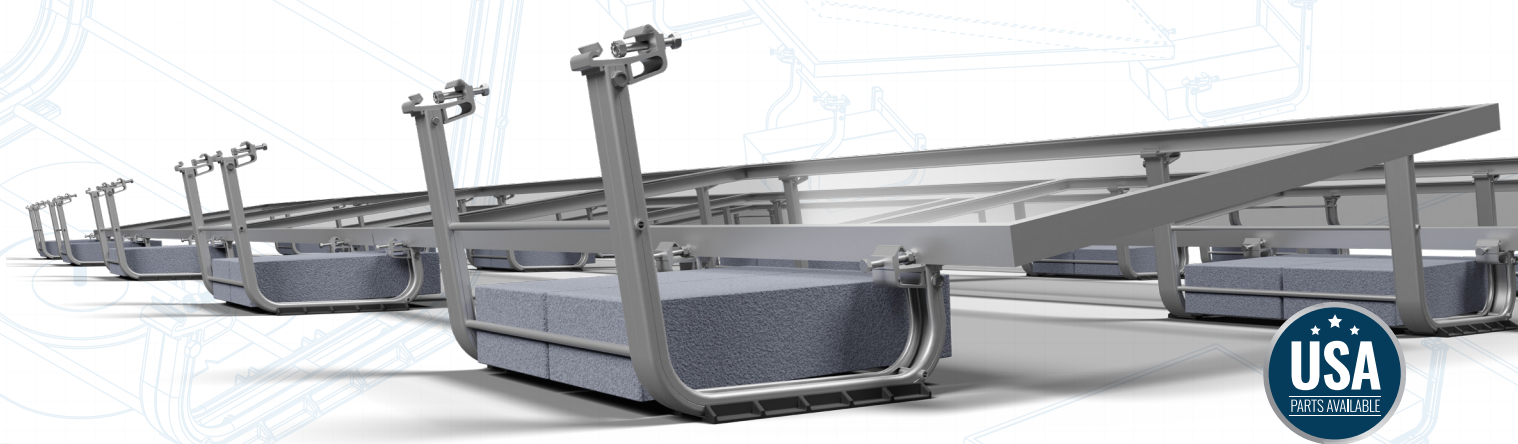

# RM10 EVO™ - DOMESTIC SOLUTION



## UNLOCK MAXIMUM SAVINGS WITH RM10 EVO™

Unirac's RM10 EVO™ racking system is domestically produced and has all the key features that customers value. RM10 EVO can qualify for the 10% Domestic Content Bonus Credit (DCBC)!

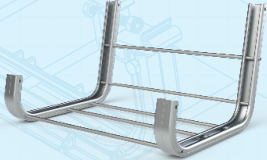
Under the IRS's First Updated Safe Harbor Guidance (Notice 2025-08), the RM10 EVO™ racking system may contribute up to 19.6% of the total 45% domestic content requirement for a complete PV installation for MLPE-based systems. When paired with select domestic content inverters on the market, the RM10 EVO™ racking system can play a pivotal role in meeting the 45% domestic content threshold!

|  |   |   |   |  |   |  |
|--|---|---|---|--|---|--|
|  <p><b>RAIL</b></p> <p>MLPE SYSTEMS: 15.0% - 18.7%</p> <p>STRING SYSTEMS: 15.0% - 18.7%</p> | + |  <p><b>STRUCTURAL FASTENERS</b></p> <p>MLPE MOUNT: 3.5% - 4.4%</p> <p>CLAMPS** (STRING SYSTEMS): 3.5% - 4.4%</p> | + | <p><b>DOMESTIC PRODUCTION</b></p> <p>Applies if rail and structural fastener are US manufactured</p> <p>MLPE SYSTEMS: 1.1% - 1.4%</p> <p>STRING SYSTEMS: 1.1% - 1.4%</p> | = | <p><b>DOMESTIC RACKING SYSTEM</b></p> <p>★★★★★</p> <p><b>19.6% - 24.5%</b></p> <p>MLPE SYSTEMS    STRING SYSTEMS</p> <p><b>OF 45% DCBC THRESHOLD</b></p> |
|--|---|---|---|--|---|--|

*\*The content provided in this bulletin is for informational purposes only; it is not tax advice. Unirac cannot provide, and is not providing, tax advice regarding eligibility for tax credits, including the DCBC adder, as eligibility depends on several factors including a tax payer's risk profile. Unirac is not a tax professional. The information provided here is Unirac's good faith interpretation of these terms as of the publishing date of this bulletin, and that interpretation shall not be relied on for claiming the DCBC. Unirac's interpretation and use of "rails" and "structural fasteners" in this bulletin is informative, non-limiting guidance only and is not intended to impede a tax payer's interpretation of such terms. Unirac makes no representation or warranty that any customer or taxpayer will be able to claim a tax credit—including the DCBC—if it purchases Unirac domestic components. Not all parties can claim the domestic content bonus. Customers and system owners must consult their own tax advisors to determine eligibility, and customers and system owners assume all risk associated with making any tax credit claim. Unirac shall not be liable to any customer or system owner.*

*\*\*Unirac is not providing tax advice as to whether any of these components are "rails" or "structural fasteners" under Notice 2025-08. Purchasers\*.*

# RM10 EVO™ - DOMESTIC SOLUTION

## ★★★★★ DOMESTIC BAY - RAIL \*\*

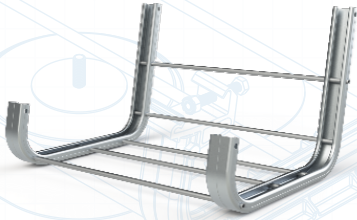

### RM10 EVO™ - RAIL

| PART NUMBER | DESCRIPTION        |
|-------------|--------------------|
| 370010-US   | RM10 EVO FIELD BAY |

## ★★★★★ DOMESTIC STRUCTURAL FASTENERS - CLAMPS\*\*

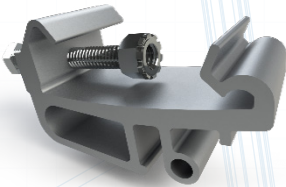

### RM10 EVO™ - CLAMP

| PART NUMBER | DESCRIPTION           |
|-------------|-----------------------|
| 370023-US   | RM10 EVO MODULE CLAMP |

## ★★★★★ DOMESTIC STRUCTURAL FASTENERS - MLPE MOUNT\*

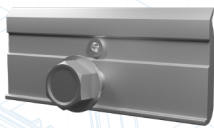

### MLPE MOUNT

| PART NUMBER | DESCRIPTION          |
|-------------|----------------------|
| MLPEMNT-US  | UNIVERSAL MLPE MOUNT |

*\*The content provided in this bulletin is for informational purposes only; it is not tax advice. Unirac cannot provide, and is not providing, tax advice regarding eligibility for tax credits, including the DCBC adder, as eligibility depends on several factors including a tax payer's risk profile. Unirac is not a tax professional. The information provided here is Unirac's good faith interpretation of these terms as of the publishing date of this bulletin, and that interpretation shall not be relied on for claiming the DCBC. Unirac's interpretation and use of "rails" and "structural fasteners" in this bulletin is informative, non-limiting guidance only and is not intended to impede a tax payer's interpretation of such terms. Unirac makes no representation or warranty that any customer or taxpayer will be able to claim a tax credit—including the DCBC—if it purchases Unirac domestic components. Not all parties can claim the domestic content bonus. Customers and system owners must consult their own tax advisors to determine eligibility, and customers and system owners assume all risk associated with making any tax credit claim. Unirac shall not be liable to any customer or system owner.*

*\*\*Unirac is not providing tax advice as to whether any of these components are "rails" or "structural fasteners" under Notice 2025-08. Purchasers\*.*