

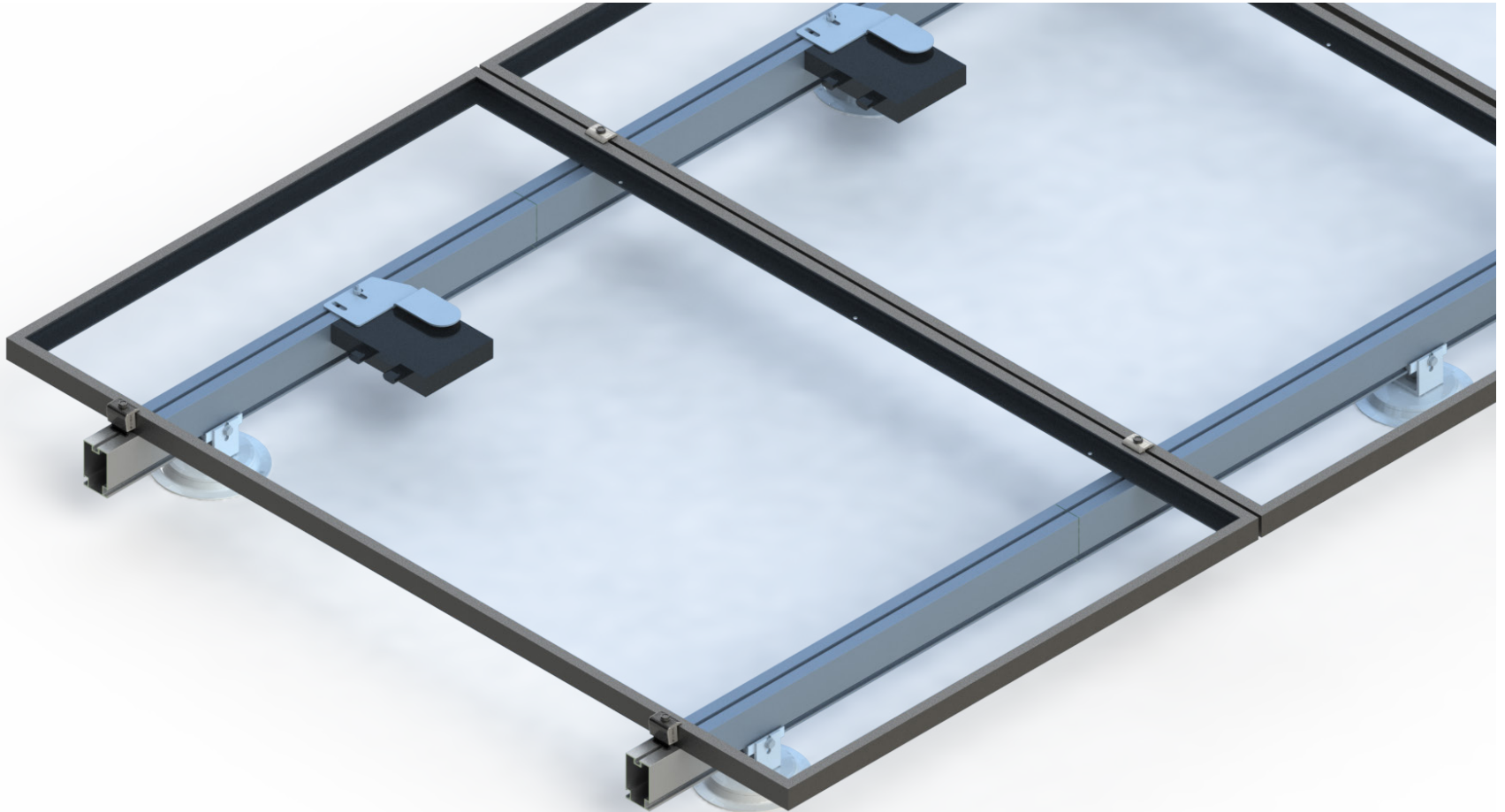

INSTALLATION GUIDE



UNIRAC Code-Compliant Installation Manual

© 2022 by Unirac, Inc. All rights reserved.



INSTALLATION GUIDE

TABLE OF CONTENTS

SYSTEM COMPONENTS.....	1-4
INSTALLATION STEPS.....	5
RM FLASHLOC INSTALLATION.....	6-7
SPLICE INSTALLATION.....	8
MICROINVERTER MOUNTING.....	9

UAF CLAMPS

UAF ENDCLAMP INSTALLATION.....	10
UAF MID CLAMP INSTALLATION.....	11

PRO SERIES

ENDCLAMP INSTALLATION.....	12
BONDING MIDCLAMP INSTALLATION.....	13
REMAINING MODULES INSTALLATION.....	14

STANDARD SERIES

ENDCLAMP INSTALLATION.....	15
BONDING MIDCLAMP INSTALLATION.....	16
REMAINING MODULES.....	17
STANDARD SYSTEM GROUNDING.....	18-19
BONDING CONNECTION GROUND PATHS.....	20-22
MODULE MAINTENANCE.....	23-24
CODE COMPLIANCE NOTES.....	25
MECHANICAL LOAD TEST.....	26
SYSTEM LEVEL FIRE CLASSIFICATION.....	27
COMPATIBLE MODULES.....	28-33

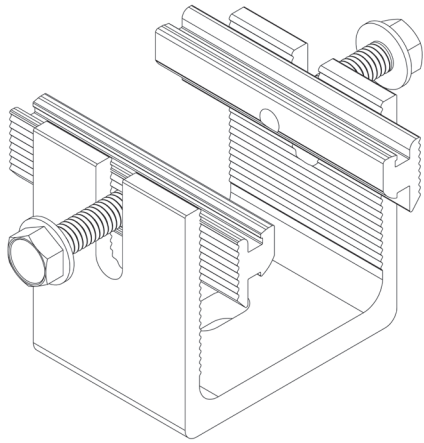

GFT U-BRACKET ASSEMBLY
(P/N: GFT-UBRAC1)

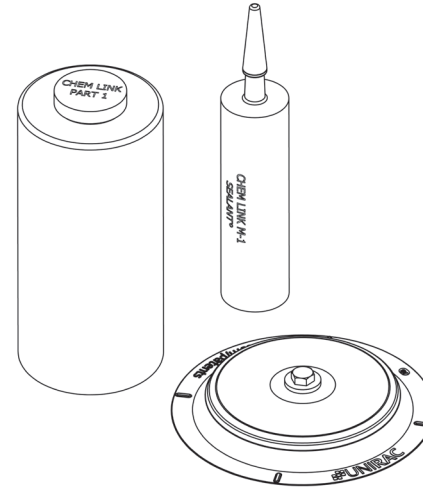

FLASHLOC RM KIT
(P/N: 310999)

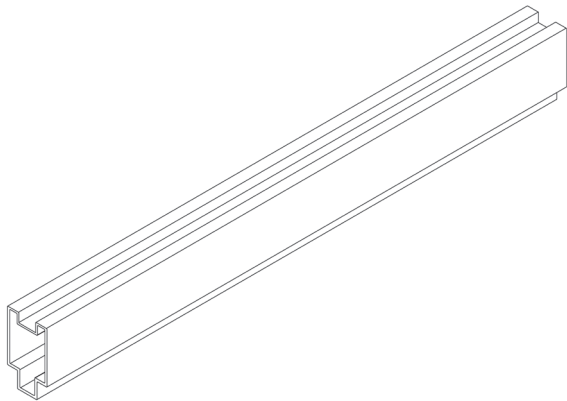

GFT SPLICE
(P/N: 404014)

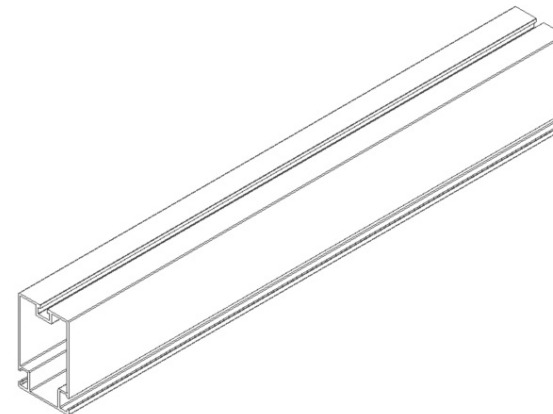

GFT RAIL
(P/N: 411166M/ 411246M)

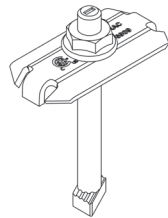
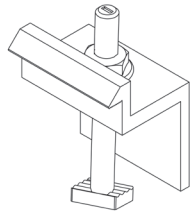

STANDARD SERIES CLAMPS

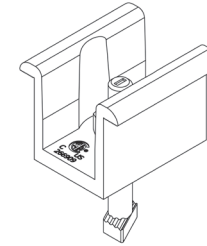
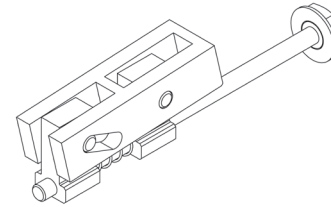

PRO SERIES CLAMPS

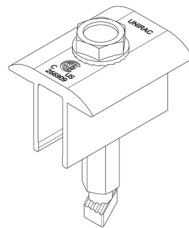
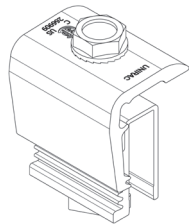

UNIVERSAL AF CLAMPS

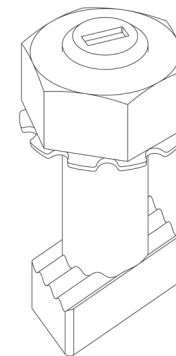

**MICROINVERTER MOUNTING BOLT
(P/N: 008013S)**

Refer to Page 4 for part numbers of above clamps

STANDARD SERIES END & MID CLAMPS

**B SIZE
ENDCLAMP**

Module Thickness
30mm to 32mm
1.18in to 1.26in

**C SIZE
ENDCLAMP**

Module Thickness
33mm to 36mm
1.30in to 1.42in

**D SIZE
ENDCLAMP**

Module Thickness
38mm to 40mm
1.50in to 1.57in

**K SIZE
ENDCLAMP**

Module Thickness
39mm to 41mm
1.54in to 1.61in

**F SIZE
ENDCLAMP**

Module Thickness
45mm to 47mm
1.77in to 1.85in

**E SIZE
ENDCLAMP**

Module Thickness
50mm to 51mm
1.97in to 2.00in



MID CLAMPS AND END CLAMPS

S.NO.	PART NUMBER	DESCRIPTION
1	302021C	SM ENDCLAMP B CLR AL
2	302021D	SM ENDCLAMP B DRK AL
3	302022C	SM ENDCLAMP C CLR AL
4	302022D	SM ENDCLAMP C DRK AL
5	302023C	SM ENDCLAMP D CLR AL
6	302023D	SM ENDCLAMP D DRK AL
7	302024C	SM ENDCLAMP E CLR AL
8	302024D	SM ENDCLAMP E DRK AL
9	302025C	SM ENDCLAMP F CLR AL
10	302025D	SM ENDCLAMP F DRK AL
11	302026C	SM ENDCLAMP K CLR AL
12	302026D	SM ENDCLAMP K DRK AL
13	302027C	SM BND MIDCLAMP BC SS
14	302027D	SM BND MIDCLAMP BC DRK SS
15	302028C	SM BND MIDCLAMP EF SS
16	302028D	SM BND MIDCLAMP EF DRK SS
17	302029C	SM BND MIDCLAMP DK SS
18	302029D	SM BND MIDCLAMP DK DRK SS
19	302030D	SM MIDCLAMP PRO DRK
20	302030M	SM MIDCLAMP PRO MILL
21	302035M	SM ENDCLAMP PRO W/CAP
22	302045D	UNIVERSAL AF MID CLAMP DRK
23	302045M	UNIVERSAL AF MID CLAMP MILL
24	302050D	UNIVERSAL AF END CLAMP DRK
25	302050M	UNIVERSAL AF END CLAMP MILL

SYMBOL	DESCRIPTION
AL	ALUMINUM
CLR	CLEAR ANODIZED
DRK	DARK BRONZE ANODIZED
SS	STAINLESS STEEL
DRK SS	BLACK OXIDE COATED STAINLESS STEEL

LETTER	SUPPORTED MODULE THICKNESS
B	30MM -32MM
C	33MM -36MM
D	38MM -40MM
K	39MM -41MM
F	45MM -47MM
E	50MM -51MM

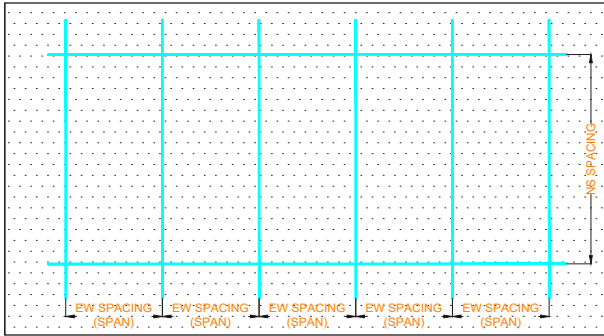

ARRAY LAYOUT

Refer to the U-Builder report for details of EW span and NS spacing. Mark the locations for the FLASHLOC RM attachments.

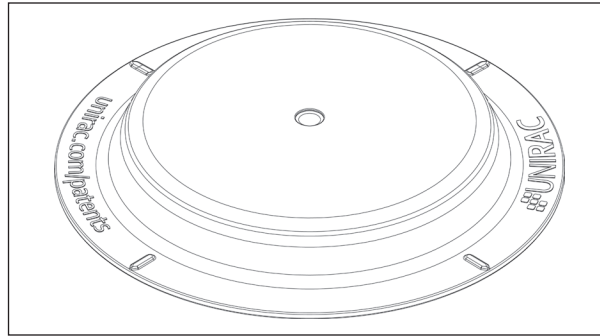

INSTALL FLASHLOC RM

Follow the instructions mentioned on *pages 6 & 7* to install the FLASHLOC RM attachment.

NOTE:

Follow the manufacturer's installation instructions when replacing the FLASHLOC RM attachment with a compatible roof attachment.

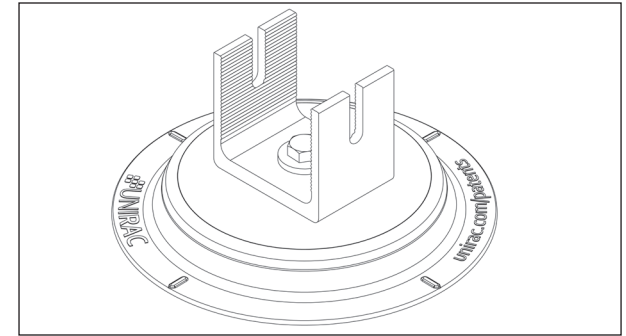

INSTALL U-BRACKET TO FLASHLOC RM

Place U-Bracket on the FLASHLOC RM attachment and secure it with the 3/8" bolt and washer included in the FLASHLOC RM kit.

Torque Value: 30 ft-lbs.

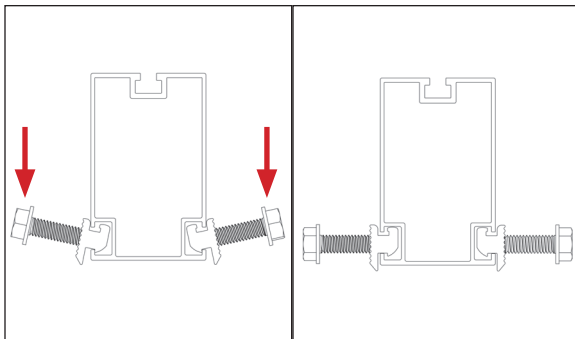

INSTALL T-BAR ON GFT RAIL

Insert T-Bars into GFT rail slot on both sides.

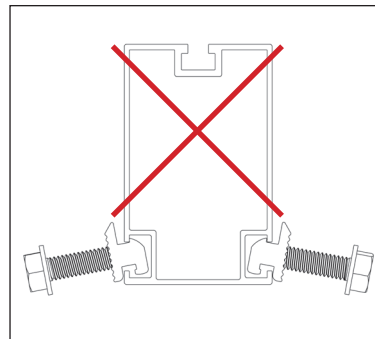

Do not install T-Bar as shown above.

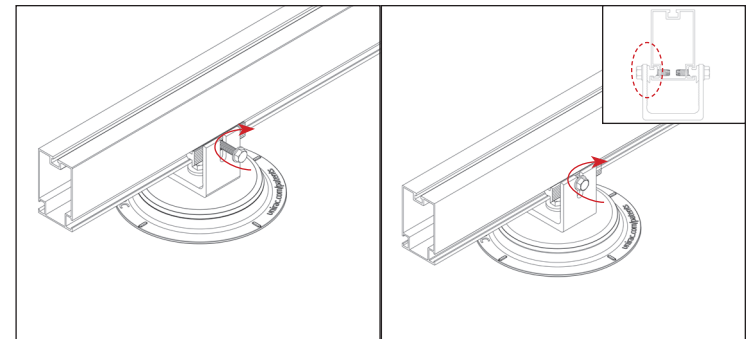

SECURE RAIL TO U-BRACKET

- Place T-bar bolts in U-Bracket slots and loosely tighten the bolts to hold at place.
- Use impact driver to fasten bolts such that it pierces through rail and secures rail to U-Bracket.
- Ensure bolt head flange flushes with U-Bracket.

Torque Value: 20 ft-lbs.



STEP 1: CLEAN SURFACE AND MARK LOCATION

- Bonding surfaces should be clean, dry and free of dirt or contamination.
- Thoroughly clean roof surface with isopropyl alcohol or denatured alcohol.
- Remove all previously applied caulk, mastic or other contaminants with a wire brush.
- Brush away all gravel or loose granules.
- Mark center point locations on the roof.

NOTE: We recommend locating Flashloc RM after layout is confirmed.



STEP 2: APPLY M1 SEALANT

- Apply a 5/16" bead of Chemlink M1 sealant to the entire bottom perimeter and to the bottom of each bolt location to be used.
- Tool M1 sealant bead to form a smooth surface along the entire bottom perimeter.

NOTE: Refer to Chemlinks application guidelines with temperatures below 40° F.

IMPORTANT: CHEMLINK TPO PRIMER MUST BE USED ON TPO SINGLE-PLY ROOF SUBSTRATES MEMBRANES PRIOR TO INSTALLATION.



STEP 3: SECURE ATTACHMENT

- Align mount using alignment marks on roof and base.
- Using fasteners specified by your P.E. of record, securely fasten attachment to the roof. Drive screws down until the base is firmly attached to the roof and the M1 sealant expands beyond the outer perimeter of the base.
- Tool M1 sealant bead around entire perimeter to form a smooth fillet.



Do Not over Torque the Screws.



STEP 4: FILL BASE WITH CHEMLINK 1-PART SEALANT

- Completely fill base with Chemlink 1-Part sealant. Sealant must completely cover all screw heads.
Do NOT overfill.
- Place cap on base and secure racking to mount with Unirac provided 3/8" hardware or other 3/8"-16 threaded hardware as specified by the P.E. of record.

IMPORTANT: To ensure robust sealing over the life of the product, the maximum allowed gap between attachment kit strut and the top surface of the flat roof attachment is 1/16".

SPLICE INSTALLATION (IF REQUIRED PER SYSTEM DESIGN)

If your installation uses splices, attach the rails together before mounting to the Flashloc RM attachment. A rail must be supported by more than one footing on both sides of the splice. There should be no gap at the splice connections.

To install, insert splice half of its length (~12") into GFT rail on both sides

TORQUE VALUE

Hex head socket size 1/2" – Do not exceed 10 ft-lbs. Do not use Anti-Seize.

Rails in splice joint configurations are considered cantilevered and must follow the cantilever rule, on both sides of the splice, which states that the maximum amount of rail that can be cantilevered is 1/3 the respective adjacent span.

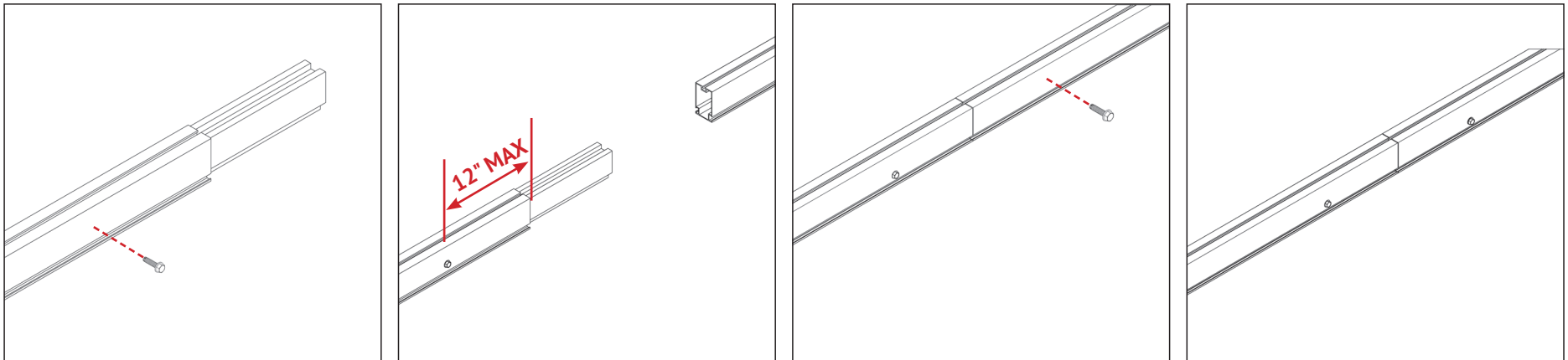

- Insert splice into GFT rail to half of its length approximately 12 inches.
- Drive self tapping screw using impact drill through rail and splice at specified distance as shown in above figure.
 - Ensure bolt head is in full contact with rail.
- Insert another GFT rail on to splice until it flushes with first rail.
- Drive self tapping screw using impact drill through rail and splice at specified distance as shown in above figure.
 - Ensure bolt head is in full contact with rail.

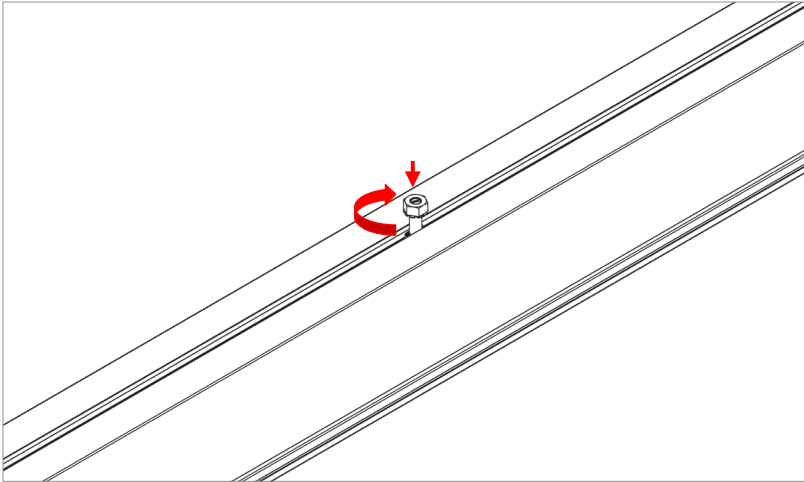

INSTALL MICROINVERTER MOUNT T-BOLT:

Apply Anti-Seize and install pre-assembled 1/4" diameter bonding T-Bolts into top 1/4" rail slot at microinverter locations. Rotate bolts into position.

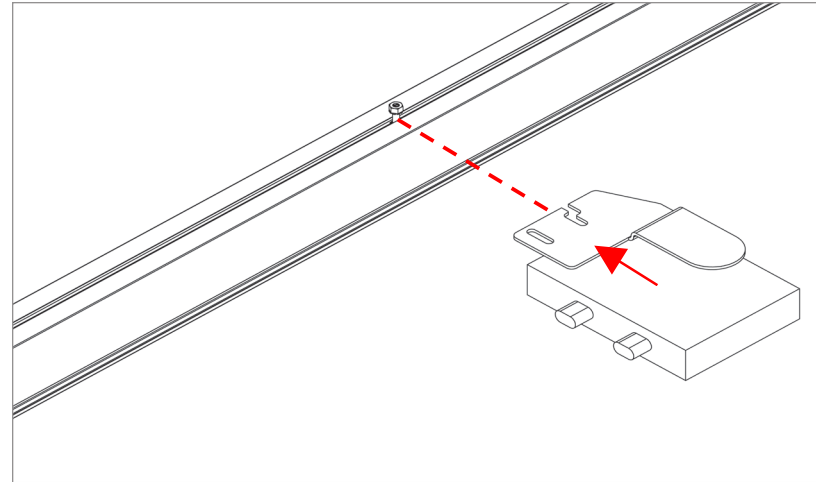

INSTALL MICROINVERTER:

Install microinverter on to the rail. Engage with bolt.

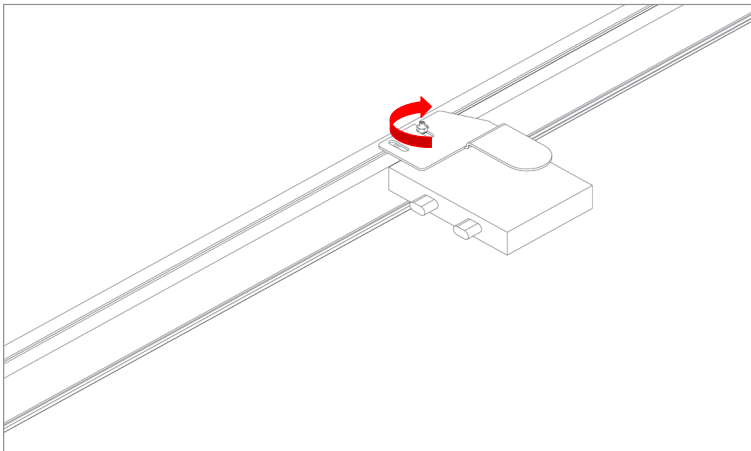

INSTALL MICROINVERTER:

Torque the 1/4" nut to **10 ft-lbs** with Anti-Seize.

NOTES:

1. MLPE Mount is certified for single use only.
2. MLPE need to be installed along with module installation.

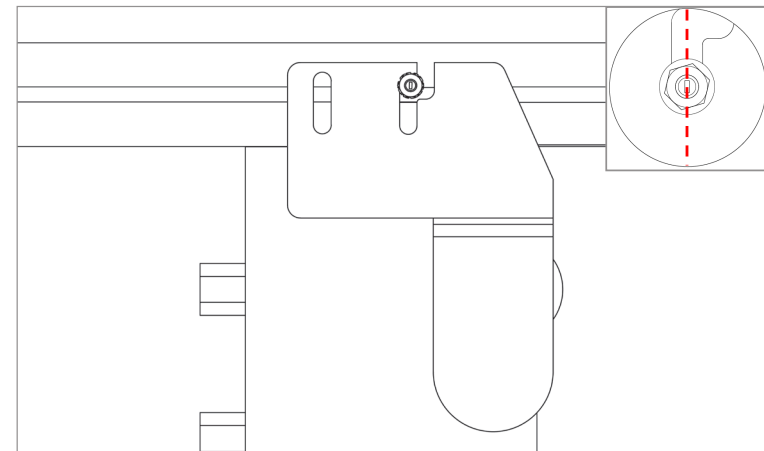

ALIGN POSITION INDICATOR:

Verify that position indicator on the T-bolt is perpendicular to rail.

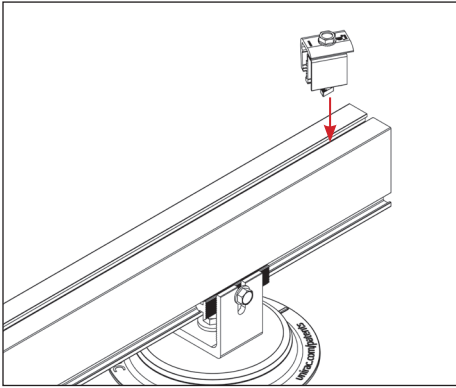

STEP 1: Position clamp to align T-bolt with rail slot. Lower clamp and insert T-bolt into rail slot.

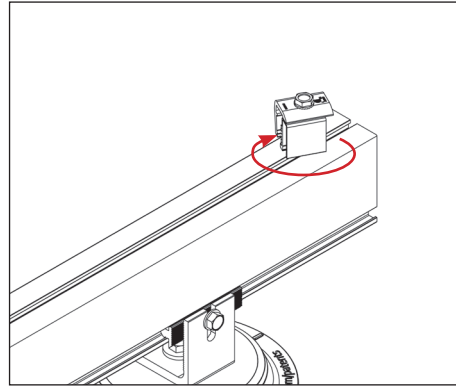

STEP 2: Rotate clamp clockwise 2/3 of a turn to engage T-bolt inside rail slot.

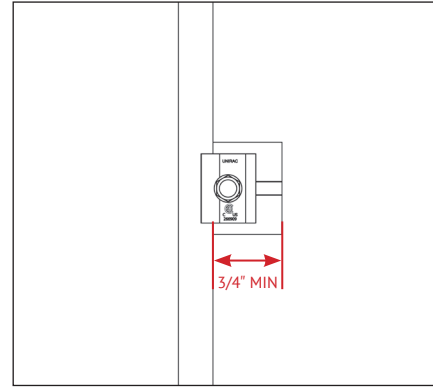

STEP 3: Place module at least 3/4" from end of rail and position clamp against module frame.

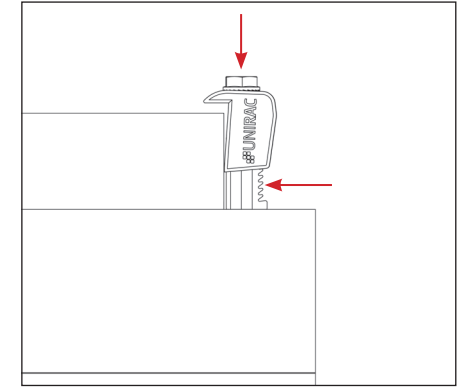

STEP 4: While applying pressure to hold the clamp against the module, push down on the module side of the clamp cap.

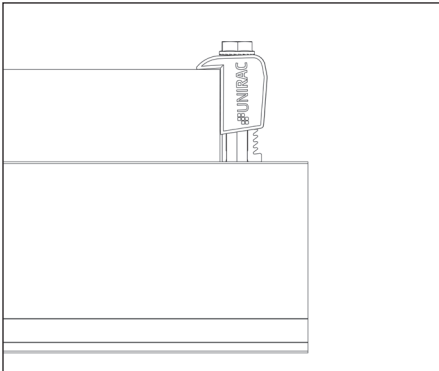

STEP 5: When the cap contacts the module frame, release and it will re-engage to the clamp base.

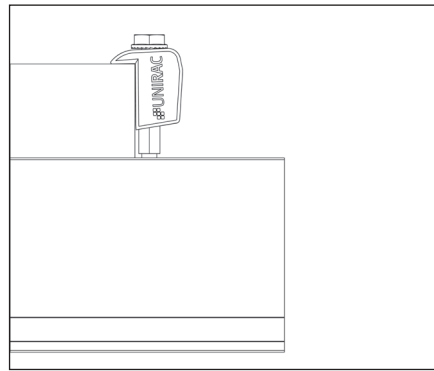

STEP 6: Tighten bolt and torque to **15 ft-lbs.**

NOTE - Universal AF End Clamps are single use.

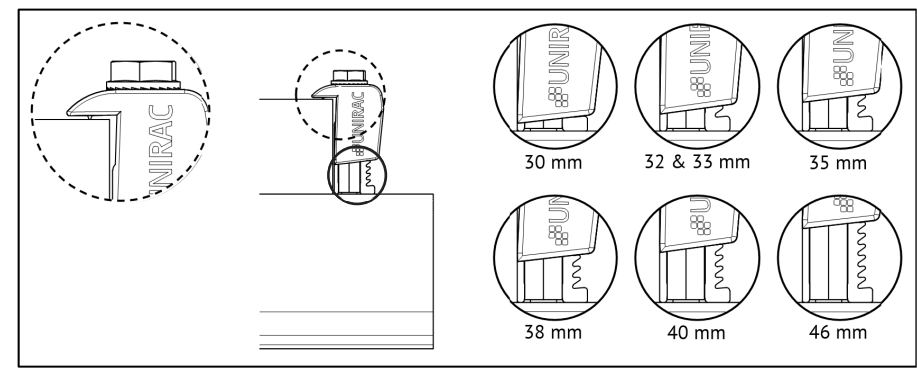

STEP 7: Confirm clamp is engaged in correct module height position and that the top of the cap is sitting level with the module frame.

NOTE: When installing 46mm modules, loosen bolt by 1 turn before positioning clamp against module frame. Do not force clamp onto module frame as this may damage the bonding pin.

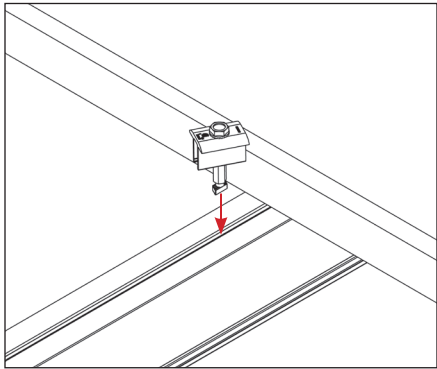

STEP 8: Position clamp to align T-bolt with rail slot. Lower clamp and insert T-bolt into rail slot

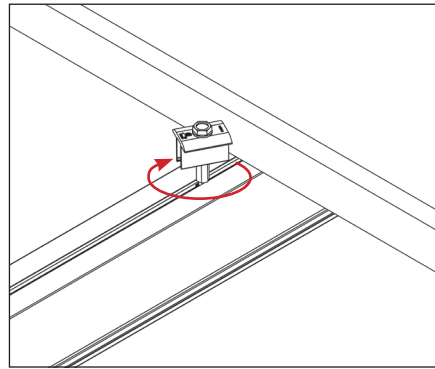

STEP 9: Rotate clamp clockwise 2/3 of a turn to engage T-bolt inside rail slot.

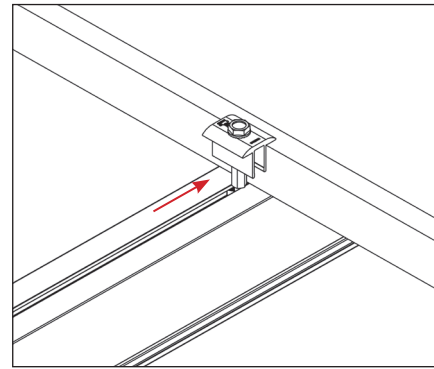

STEP 10: Slide clamp into position against module.

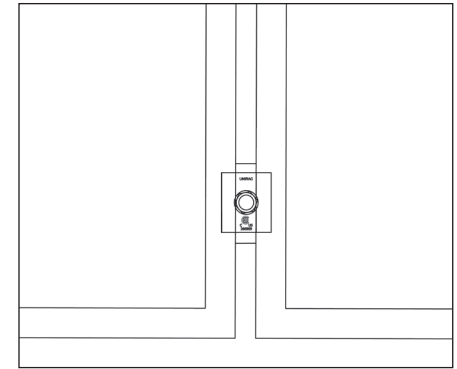

STEP 11: Place second module.

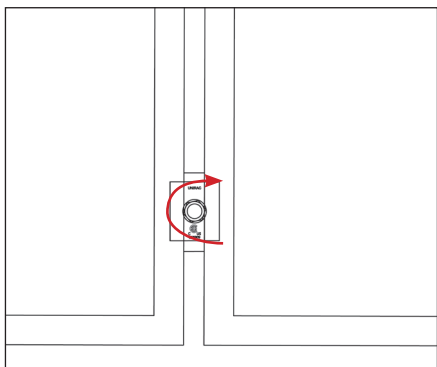

STEP 12: Tighten bolt and torque to 15 ft-lbs.

NOTE - Universal AF Mid Clamps are single use.

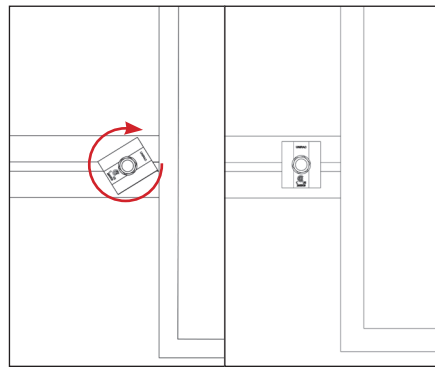

NOTE: If excessive force is applied in step 9, the cap may over-rotate causing it to be mis-aligned with the module frame. If this occurs, keep rotating the cap clockwise until it returns to the original position.

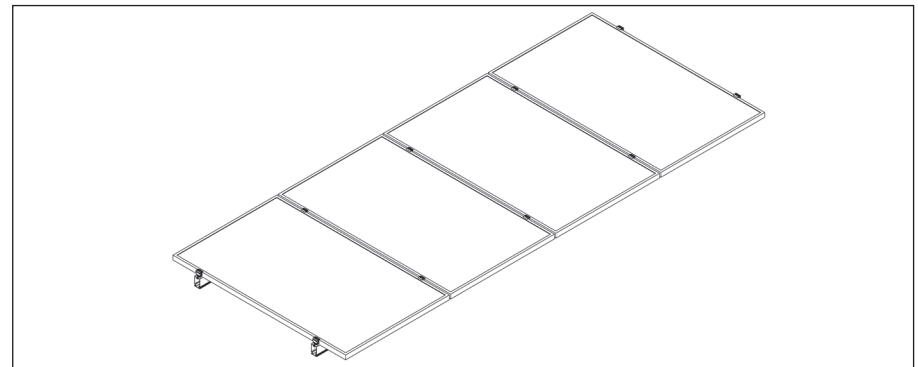

STEP 13: Engage each module with the previously positioned Midclamp assemblies and complete modules installation.

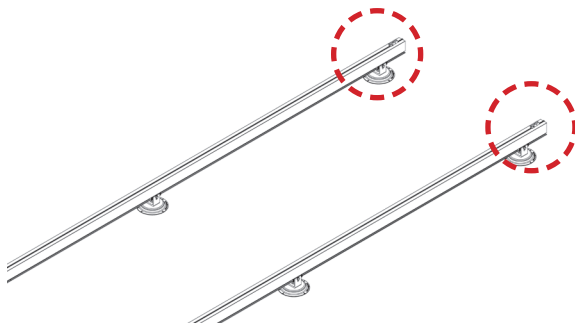

INSTALL MODULE END CLAMPS: The End clamp is supplied as an assembly with a 1/2" hex head bolt that is accessible at the ends of rails. The clamp should be installed on the rails prior to installing end modules.

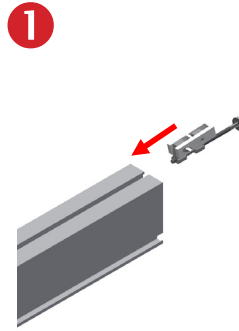

INSTALL END CLAMPS ON RAIL: Slide end clamp on to rail by engaging the two t-guide brackets with the top slot of the rails. **Ensure bolt is extended as far as possible so that clamp is positioned at max. distance from end of rail.**

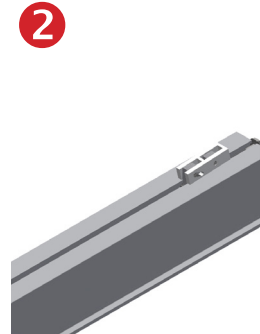

POSITION END CLAMPS: Slide end clamp assembly on to rail until bolt head engages with end of rail. **End clamps are positioned on rails prior to the first end module and prior to the last end module.**

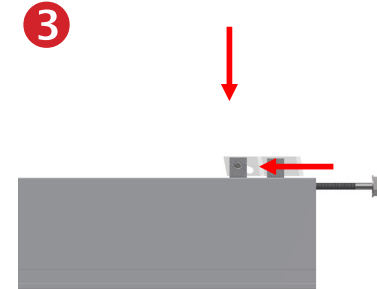

NOTE: To assist insertion of clamp into rail slot, Pressure may be applied to top or side of bracket as shown. Do not force clamp into rail by pushing on bolt with excessive force.

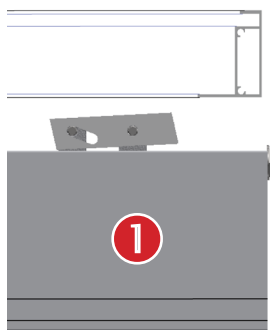

INSTALL FIRST MODULE: Install the first end module onto rails with the flange of the module frame positioned between end clamps and ends of rails.

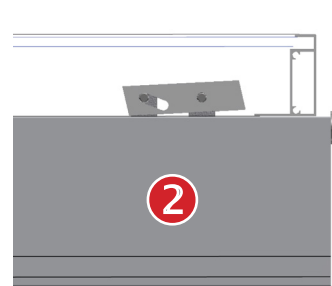

ENGAGE CLAMP: While holding module in position and with flange in full contact with rail, rotate end clamp bolt until clamp engages with flange to provide clamp force.

To ensure bolt is not over-torqued, use low torque setting on drill or If using an impact driver, stop rotation as soon as impact action of driver begins.

TORQUE VALUE

End clamp bolt to 5 ft-lbs, No anti-seize

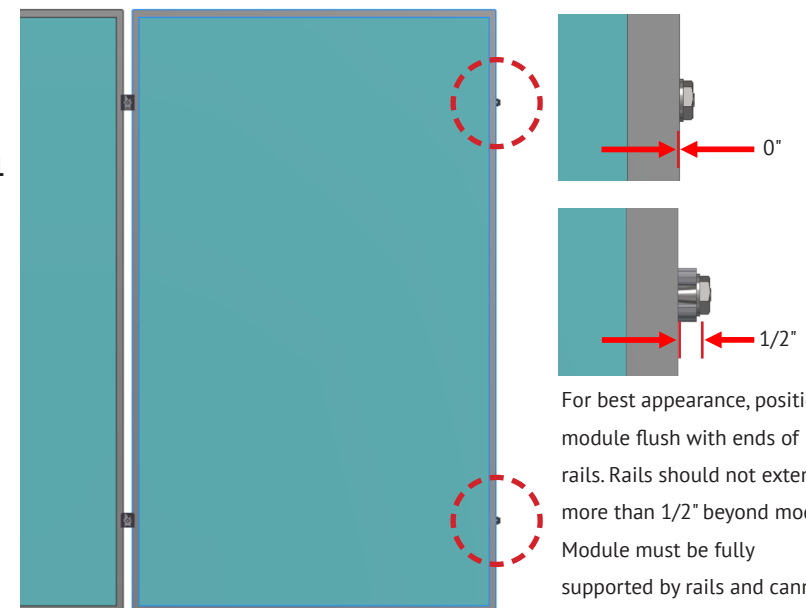
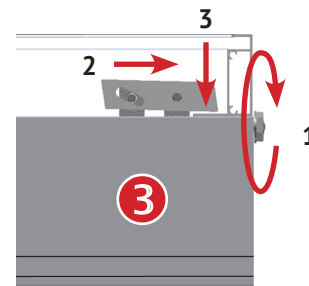

For best appearance, position module flush with ends of rails. Rails should not extend more than 1/2" beyond module. Module must be fully supported by rails and cannot overhang ends of rails.

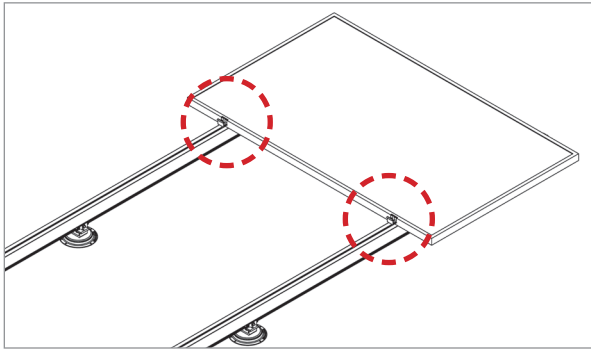

INSTALL MIDCLAMPS: Midclamp is supplied as an assembly with a T-bolt for module installation. Clamp assemblies may be positioned in rail near point of use prior to module placement.

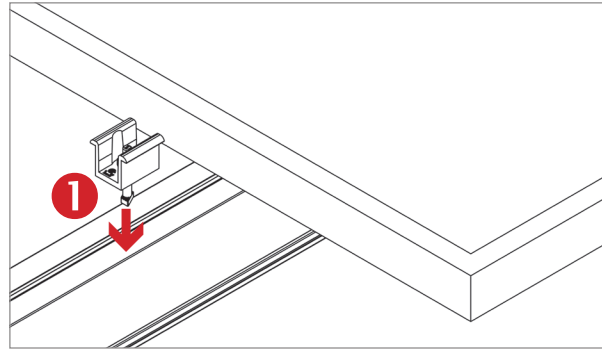

INSERT MIDCLAMP ASSEMBLY: Insert 1/4" T-Bolt into top slot of rail

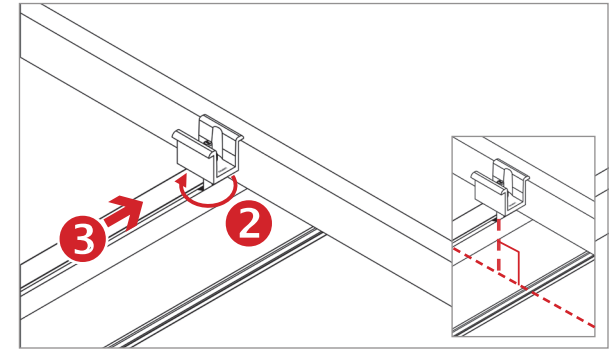

MIDCLAMP: Rotate midclamp assembly and slide until clamp is against module frame. Do not tighten nut until next module is in position. Ensure bolt is perpendicular to rail.

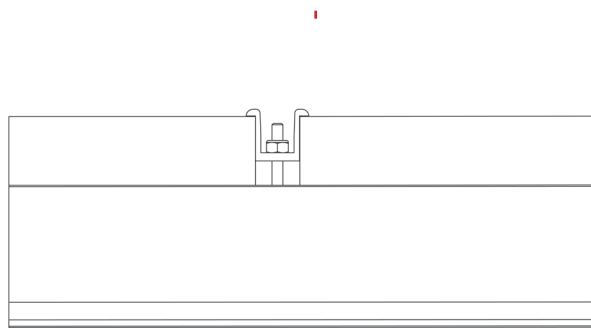

PLACE ADJACENT MODULE AGAINST CLAMPS: Modules must be tight against clamps with no gaps. Tighten nut to required torque.

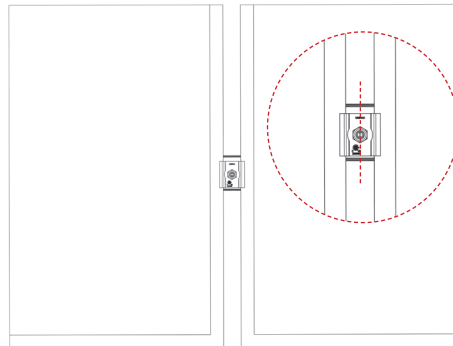

POSITION INDICATOR - SERRATED T-BOLT: Verify the T-bolt position indicator is perpendicular to the rail.

TORQUE VALUE: 11 ft-lbs. No anti-seize.

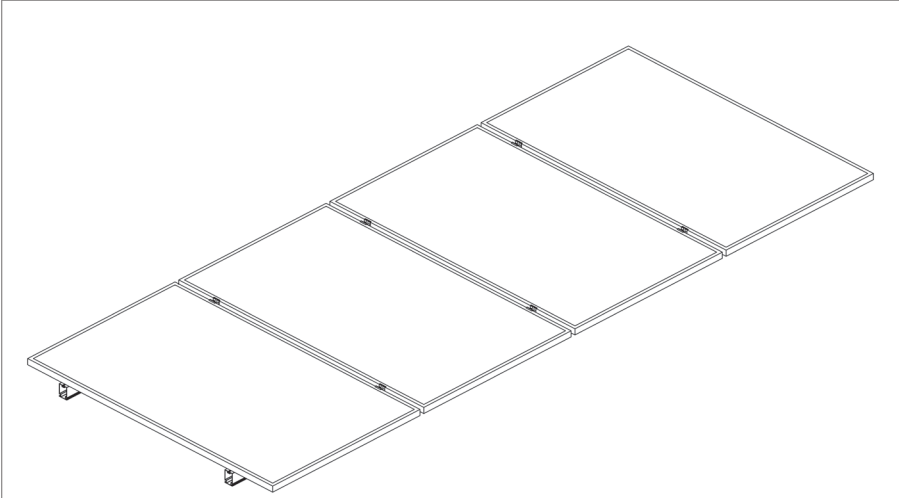

FINISH MODULE INSTALLATION: Proceed with module installation. Engage each module with the previously positioned Mid clamp assembly:

- Install second module
- Install remaining Midclamps & modules & position alignment marks
- Install Endclamps & position alignment marks
- Cut rail to desired length (MIN 1/2")

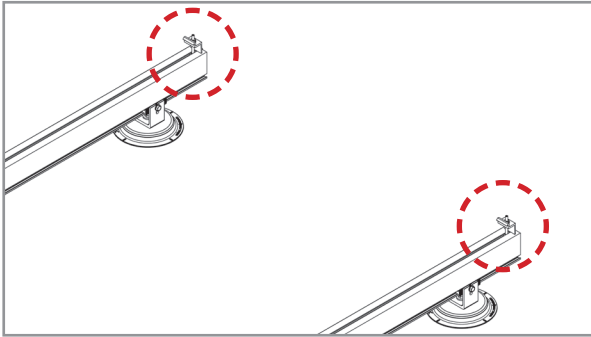

INSTALL MODULE ENDCLAMPS: The Endclamp is supplied as an assembly with a T-bolt, serrated flange nut, and washer. The washer retains the clamp at the top of the assembly. This will enable the clamp to remain upright for module installation.

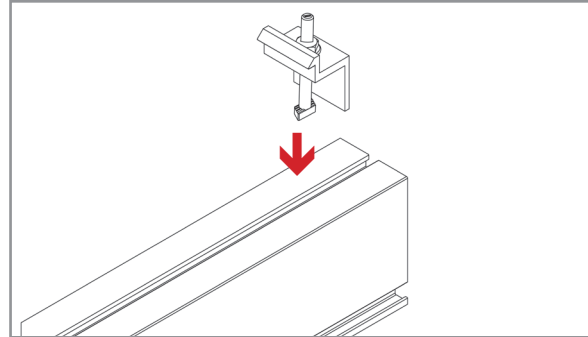

INSERT ENDCLAMP T-BOLT: Insert 1/4" T-bolt into rail.

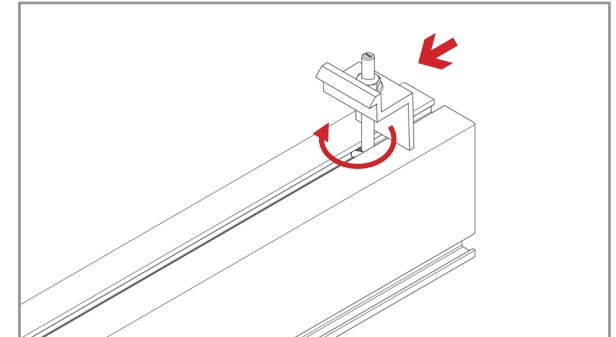

ROTATE ENDCLAMP T-BOLT: Rotate T-bolt into position. Verify that the position indicator & T-bolt shaft are angled in the correct position.

End clamps are positioned on rails prior to the first end module and installed after the last end module.

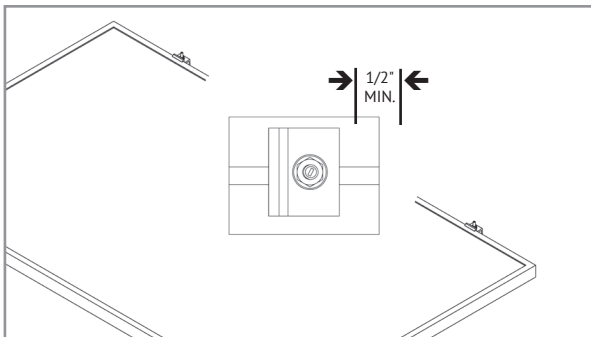

INSTALL FIRST MODULE: Install the first end module onto rails. Engage module frame with End-clamps. Verify that the position indicator & T-bolt shaft are angled in the correct position.

TORQUE VALUE: 1/4" nuts to 10 ft-lbs. with Anti Seize

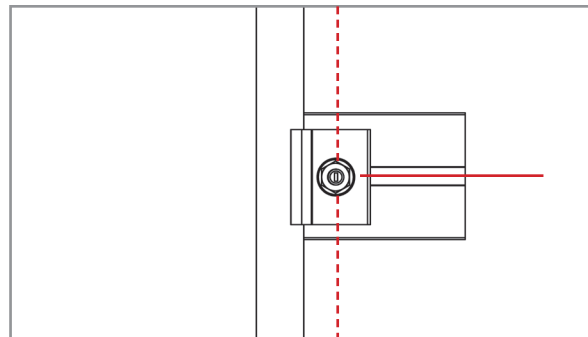

POSITION INDICATOR - SERRATED T-BOLT: Verify the T-bolt position indicator is perpendicular to the rail.

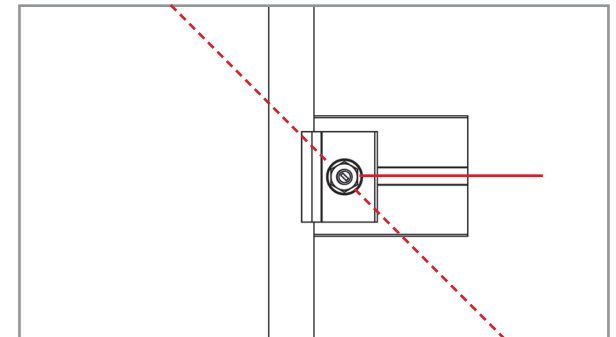

POSITION INDICATOR - NON-SERRATED T-BOLT: Verify the T-bolt position indicator is angled as shown. **FOR USE WITH MILL FINISH RAIL ONLY.**

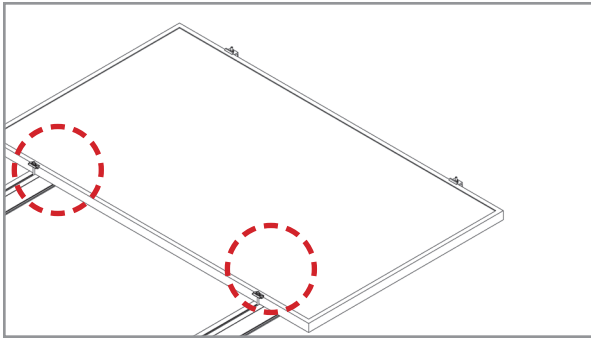

INSTALL MIDCLAMPS: Midclamp is supplied as an assembly with a T-bolt for module installation. Clamp assemblies may be positioned in rail near point of use prior to module placement.

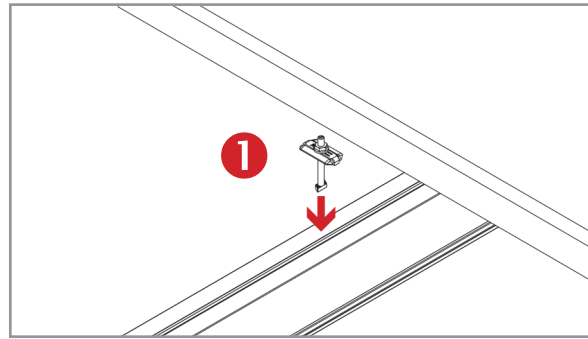

INSERT MIDCLAMP T-BOLT: Apply Anti-Seize and insert 1/4" T-bolt into rail.

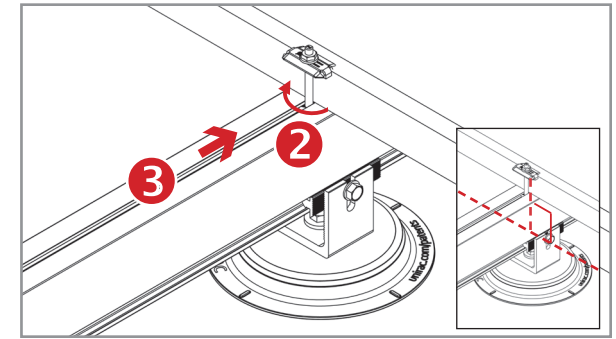

ROTATE MIDCLAMP T-BOLT: Rotate bolt into position and slide until bolt and clamp are against module frame. Do not tighten nut until next module is in position. Verify that the position indicator & T-bolt shaft are angled in the correct position.

NOTE: Apply Anti-Seize to each Mid Clamp prior to installation.

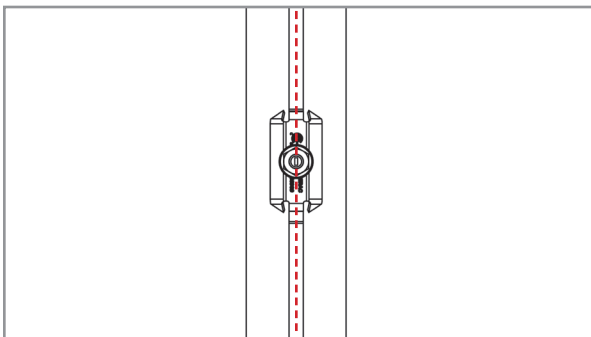

POSITION INDICATOR - SERRATED T-BOLT: Verify the T-bolt position indicator is perpendicular to the rail.

TORQUE VALUE: 1/4" nuts to 10 ft-lbs. with Anti Seize

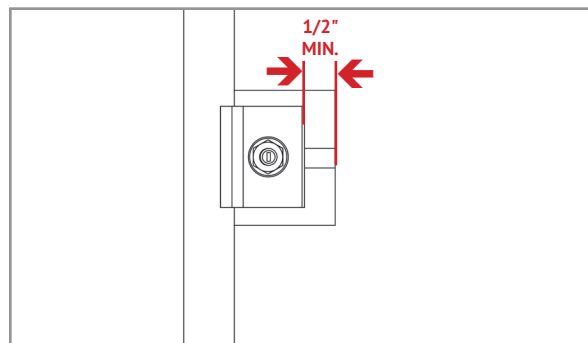

POSITION T-BOLT ALIGNMENT MARKS & CUT RAIL: Verify that the position indicator(s) & T-bolt shaft(s) are angled in the correct position. Trim off any excess rail, being careful not to cut into the roof. Allow 1/2" between the Endclamp and the end of the rail.

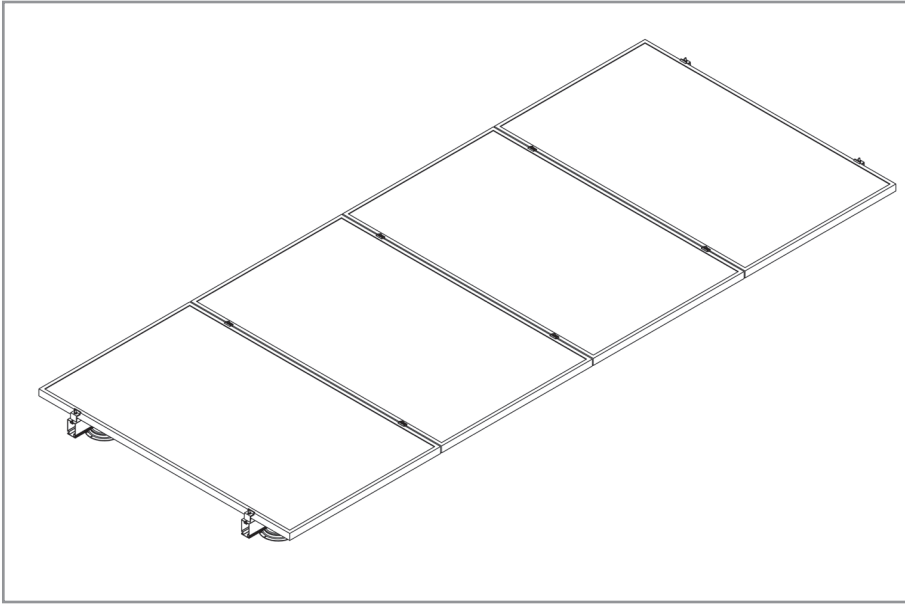

FINISH MODULE INSTALLATION: Proceed with module installation. Engage each module with the previously positioned clamp assembly:

- Install second module
- Install remaining Midclamps & modules & position alignment marks
- Install Endclamps & position alignment marks
- Cut rail to desired length (MIN 1/2")

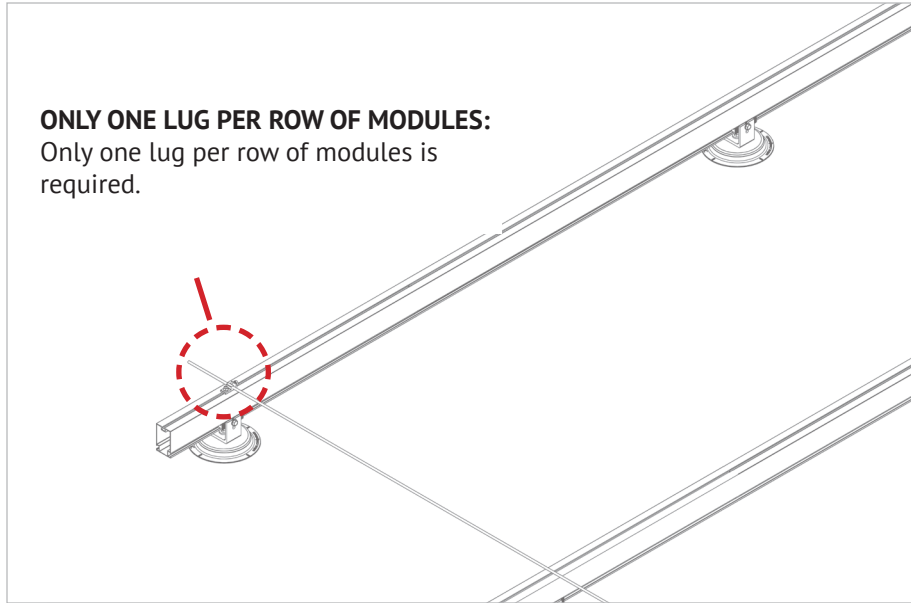

GROUNDING LUG MOUNTING DETAILS:

Details are provided for both the WEEB and IlSCO products. The WEEBLug has a grounding symbol located on the lug assembly. The IlSCO lug has a green colored set screw for grounding indication purposes. Installation must be in accordance with NFPA NEC 70, however the electrical designer of record should refer to the latest revision of NEC for actual grounding conductor cable size.

Required if not using approved integrated grounding microinverters

GROUNDING LUG - BOLT SIZE & DRILL SIZE		
GROUND LUG	BOLT SIZE	DRILL SIZE
WEEBLug	1/4"	N/A - Place in Top SM Rail Slot
ILSCO Lug	#10-32	7/32"

- Torque value depends on conductor size.
- See product data sheet for torque value.

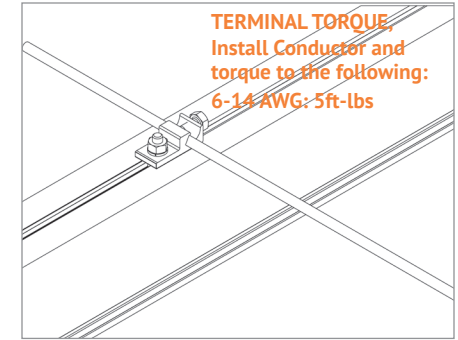
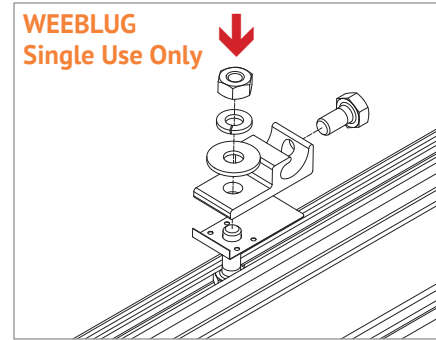

WEEBLUG CONDUCTOR - UNIRAC P/N 0080025:

Apply Anti Seize and insert a bolt in the aluminum rail and through the clearance hole in the stainless steel flat washer. Place the stainless steel flat washer on the bolt, oriented so the dimples will contact the aluminum rail. Place the lug portion on the bolt and stainless steel flat washer. Install stainless steel flat washer, lock washer and nut. Tighten the nut until the dimples are completely embedded into the rail and lug.

TORQUE VALUE 10 ft lbs.

See product data sheet for more details, Model No. WEEB-LUG-6.7

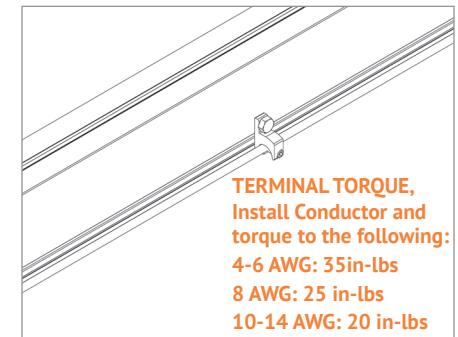
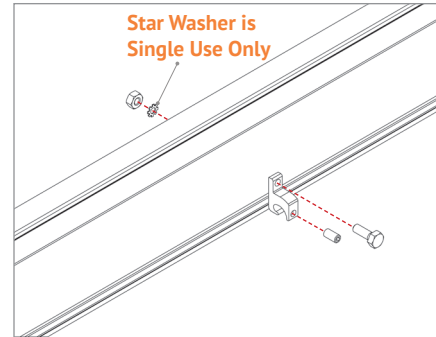

ILSCO LAY-IN LUG CONDUCTOR - UNIRAC P/N 008009P: Alternate Grounding Lug - Drill, deburr hole and bolt thru both rail walls per table.

TORQUE VALUE 5 ft lbs.

See ILSCO product data sheet for more details, Model No. GBL-4DBT.

NOTE: ISOLATE COPPER FROM ALUMINUM CONTACT TO PREVENT CORROSION

GROUND LUG INSTALLATION

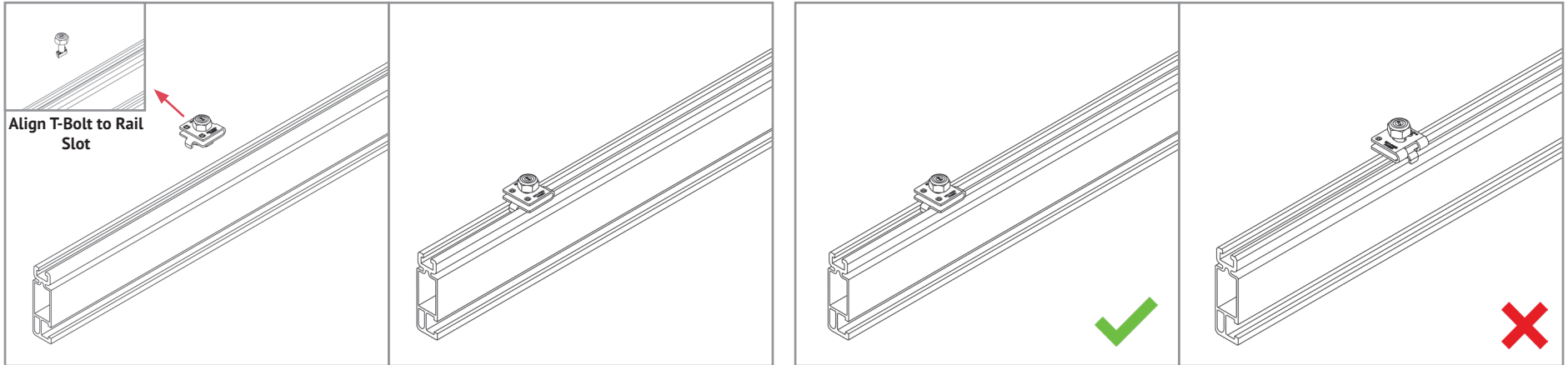

STEP 1: POSITION THE GROUND LUG

- Place the Ground Lug on the rail with pre-assembled 1/4" T-bolt and nut.
- Ensure the Ground Lug Clip tabs are positioned inside the rail.

**GROUND LUG CLIP TABS
INSIDE THE RAIL**

**GROUND LUG CLIP TABS
OUTSIDE THE RAIL**

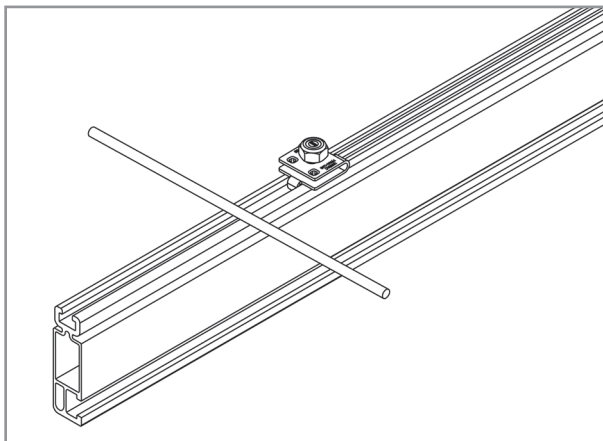

STEP 2: INSERT GROUNDING WIRE

- Insert the copper grounding wire (6-12 AWG) into the Ground Lug Clip.

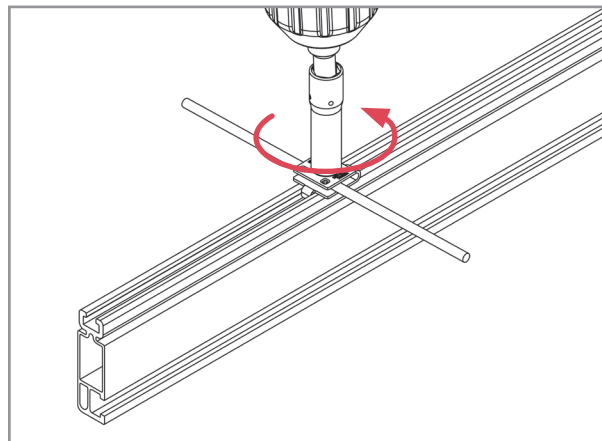

STEP 3: SECURE GROUND LUG TO RAIL

- Tighten the 1/4" nut to secure the Ground Lug to Rail.

Torque the 1/4" nut to 15 ft-lbs.

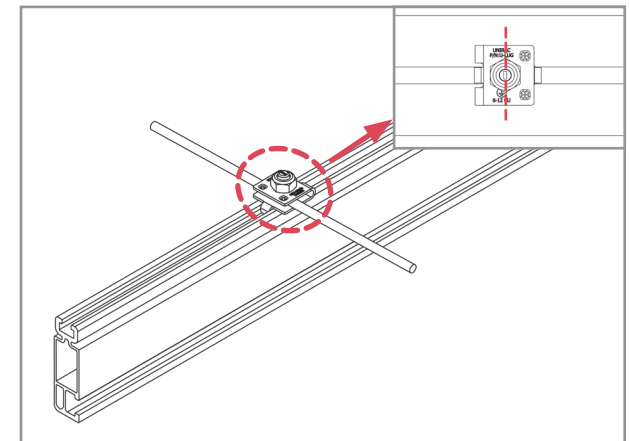

ALIGN POSITION INDICATOR

- Verify that the position indicator on the bolt is perpendicular to the rail.

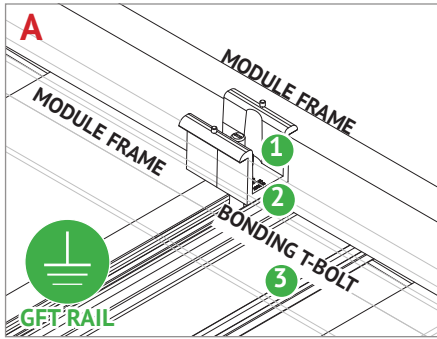

PRO-SERIES CLAMPS

BONDING MIDCLAMP ASSEMBLY

- 1 Aluminum mid clamp with stainless steel bonding pins that pierce module frame anodization to bond module to module through clamp
- 2 Stainless steel nut bonds aluminum clamp to stainless steel T-bolt
- 3 Serrated T-bolt head penetrates rail anodization to bond T-bolt, nut, clamp, and modules to SM rail

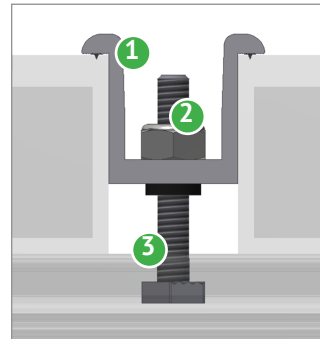

STANDARD SERIES CLAMPS

BONDING MIDCLAMP ASSEMBLY

- 1 Stainless steel Midclamp points, 2 per module, pierce module frame anodization to bond module to module through clamp.
- 2 Serrated flange nut bonds stainless steel clamp to stainless steel T-bolt
- 3 Serrated T-bolt head penetrates rail anodization to bond T-bolt, nut, clamp, and modules to grounded SM rail.

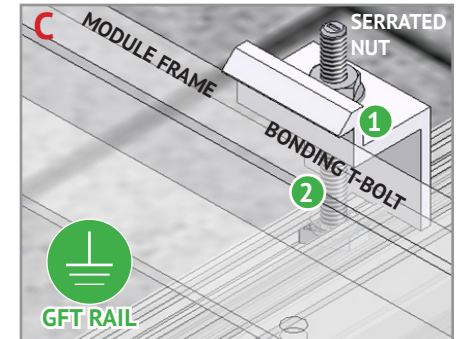

ENDCLAMP ASSEMBLY

- 1 Serrated flange nut bonds aluminum Endclamp to stainless steel T-bolt
 - 2 Serrated T-bolt head penetrates rail anodization to bond T-bolt, nut, and Endclamp to grounded SM rail
- Note: End clamp does not bond to module frame.**

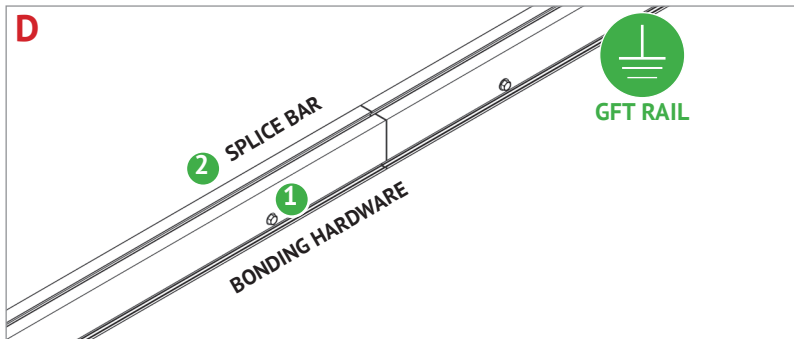

BONDING RAIL SPLICE BAR

- 1 Bonding Hardware creates bond between splice bar and each rail sections
- 2 Aluminum splice bar spans across rail gap to create rail to rail bond. At least one side of the splice will have the rail grounded.

Note: Splice bar and bolted connection are structural. The splice bar function is rail alignment, strength and bonding.

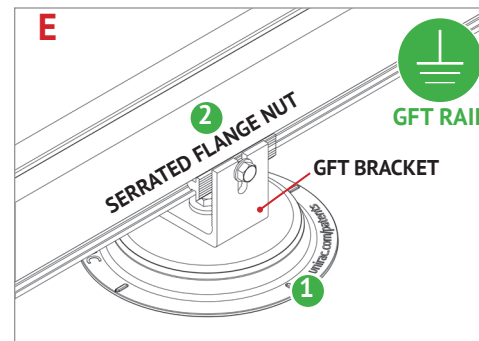

RAIL TO GFT BRACKET

- 1 Serrated flange nut removes L-foot anodization to bond L-Foot to stainless steel T-bolt
- 2 Serrated T-bolt head penetrates rail anodization to bond T-bolt, nut, and L-foot to grounded SM rail

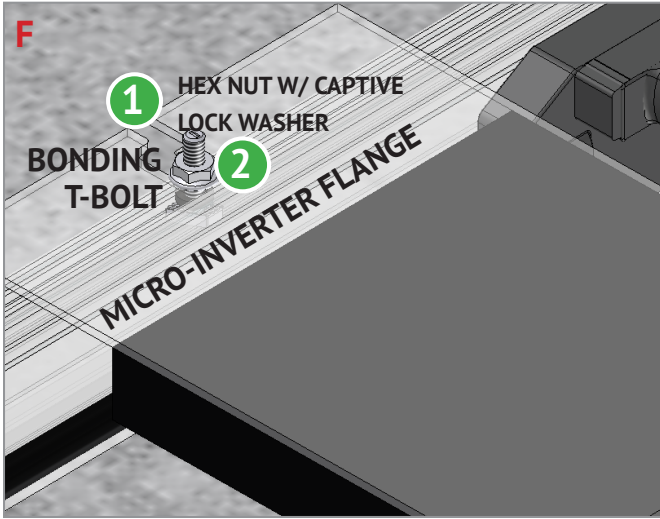

BONDING MICROINVERTER MOUNT

- 1 Hex nut with captive lock washer bonds metal micro-inverter flange to stainless steel T-bolt.
- 2 Serrated T-bolt head penetrates rail to bond T-bolt and nut to grounded Ascender rail.

CAUTION

1. If loose components or loose fasteners are found during periodic inspection, re-tighten immediately.
2. Any components showing signs of corrosion or damage that compromise safety shall be replaced immediately.

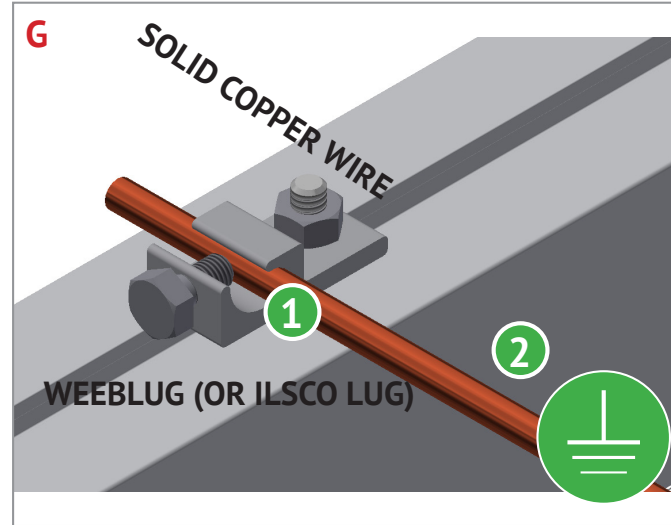

RACK SYSTEM GROUND

- 1 Weeb washer dimples pierce rail to create bond between rail and lug
- 2 Solid copper wire connected to lug is routed to provide final system ground connection.

NOTE: IlSCO lug can also be used when secured to the side of the rail.



Note:
Only one lug per module row required

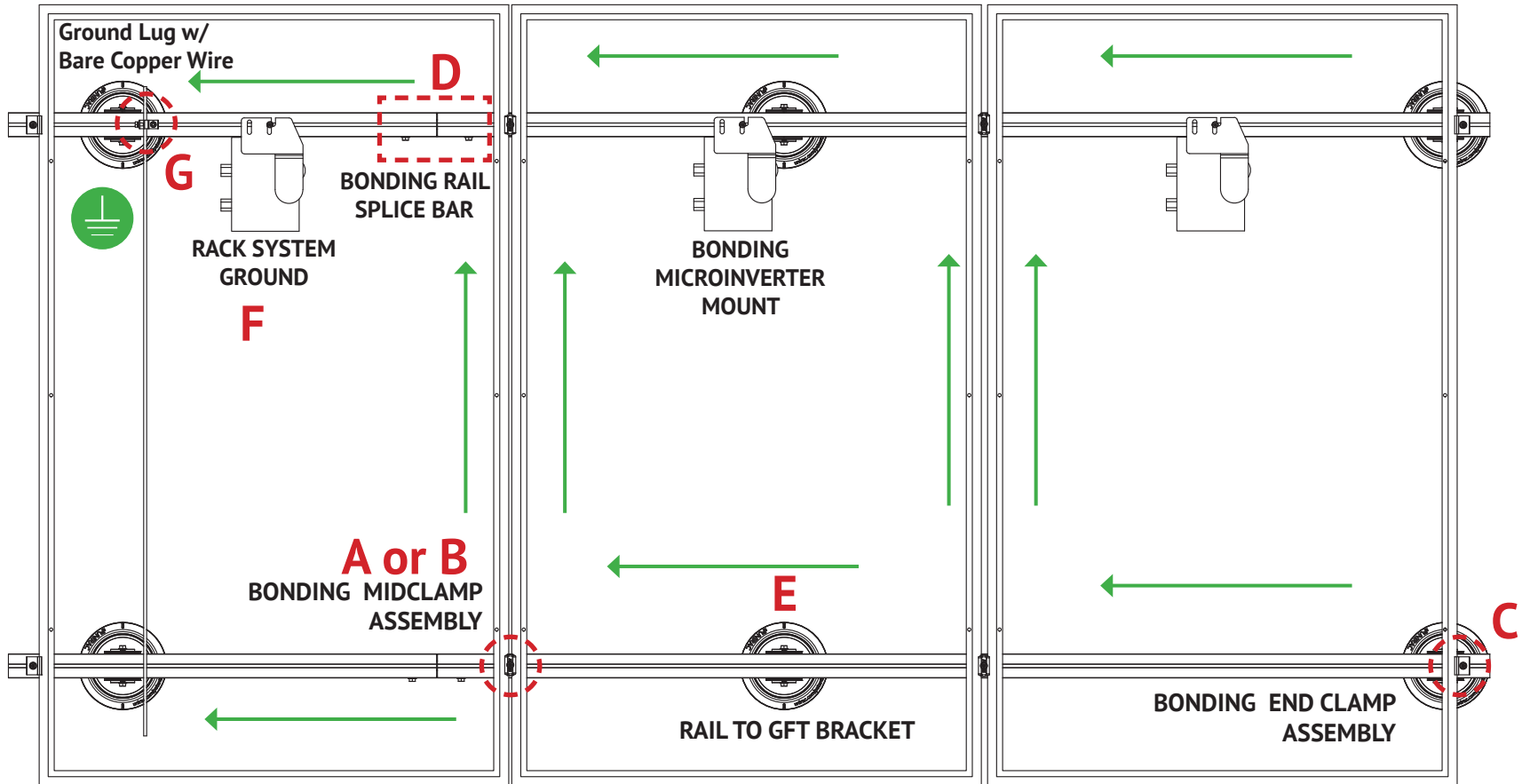

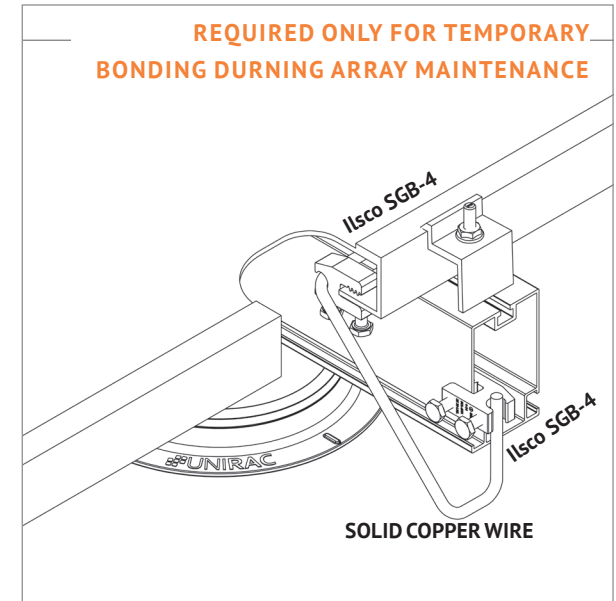
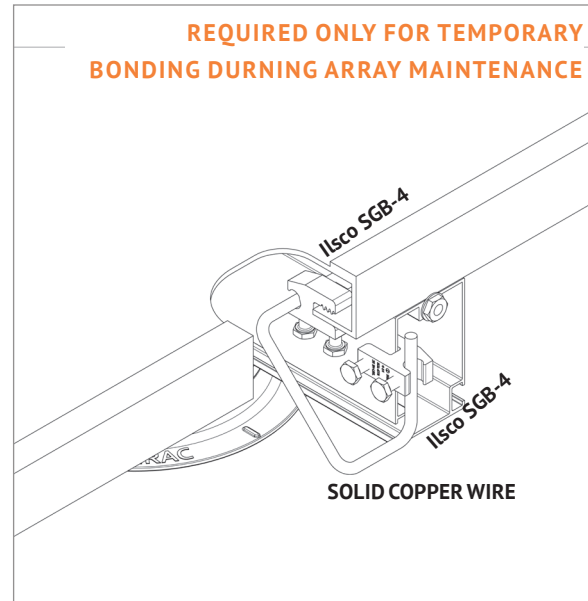
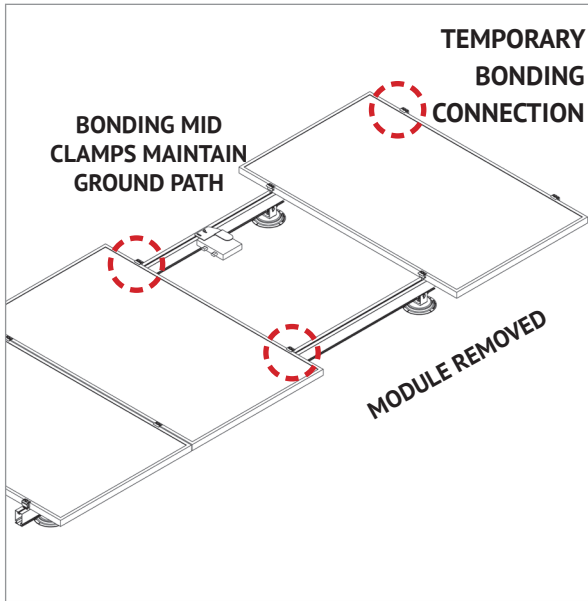

TEMPORARY BONDING CONNECTION DURING ARRAY MAINTENANCE

When removing modules for replacement or system maintenance, any module left in place that is secured with a bonding Midclamp will be properly grounded. If a module adjacent to the end module of a row is removed or if any other maintenance condition leaves a module without a bonding mid clamp, a temporary bonding connection must be installed as shown

- Attach IlSCO SGB4 to wall of rail
- Attach IlSCO SGB4 to module frame
- Install solid copper wire jumper to IlSCO lugs

ELECTRICAL CONSIDERATIONS

GFT Flush Mount is intended to be used with PV modules that have a system voltage less than or equal to that allowable by the NEC. For standard system grounding a minimum 10AWG, 105°C copper grounding conductor should be used to ground a 1000 VDC system, according to the National Electric Code (NEC). It is the installer's responsibility to check local codes, which may vary. See below for interconnection information.

INTERCONNECTION INFORMATION

There is no size limit on how many GFT Flush Mount & PV modules can be mechanically interconnected for any given configuration, provided that the installation meets the requirements of applicable building and fire codes.

GROUNDING NOTES

The installation must be conducted in accordance with the National Electric Code (NEC) and the authority having jurisdiction. Please refer to these resources in your location for required grounding lug quantities specific to your project.

The grounding / bonding components may overhang parts of the array so care must be made when walking around the array to avoid damage.

Conductor fastener torque values depend on conductor size. See product data sheets for correct torque values.

UL2703 CERTIFICATION MARKING LABEL

Unirac GFT Flush Mount is listed to UL 2703. Certification marking is embossed on all mid clamps as shown. Labels with additional information will be provided. After the racking system is fully assembled, a single label should be applied to the GFT Flush Mount rail at the edge of the array. Before applying the label, the corners of the label that do not pertain to the system being installed must be removed so that only the installed system type is showing.

Note: The sticker label should be placed such that it is visible, but not outward facing.

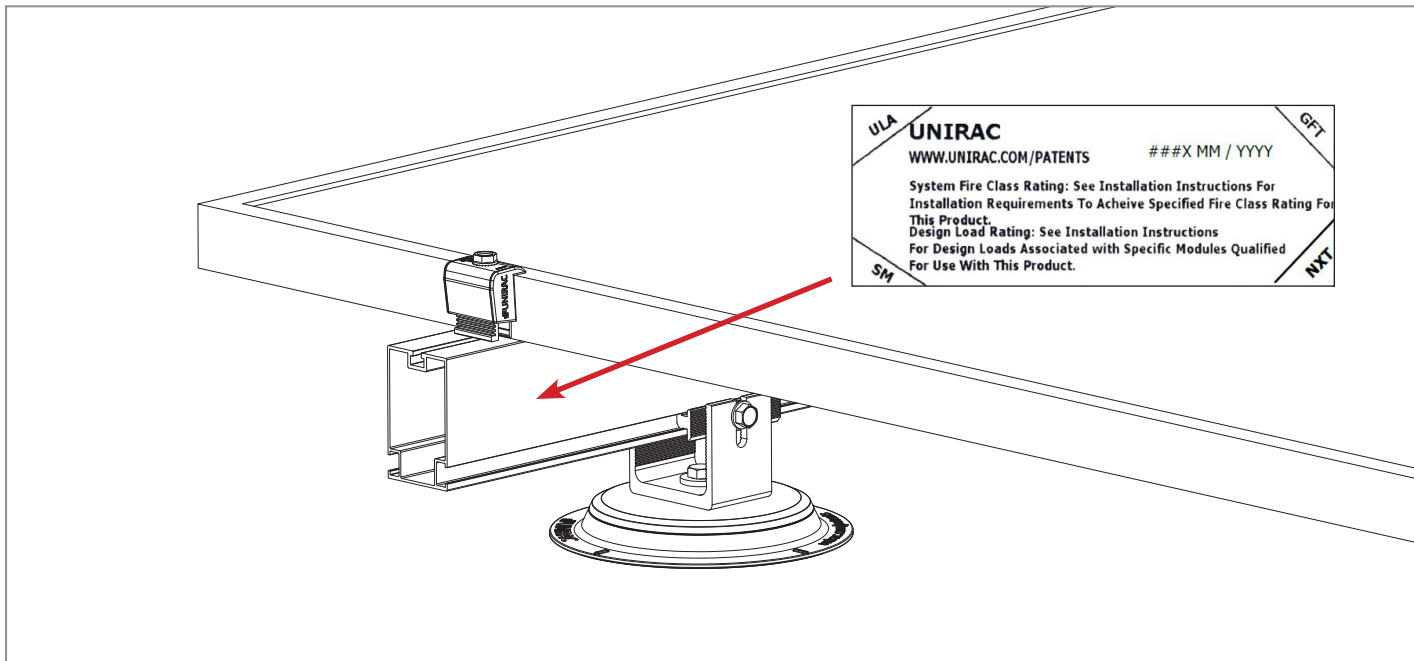
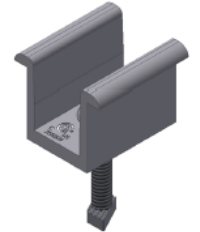

The GFT Flush Mount system has been certified and listed to the UL 2703 standard (Rack Mounting Systems and Clamping Devices for Flat-Plate Photovoltaic Modules and Panels). This standard included electrical grounding, electrical bonding, mechanical load and fire resistance testing.

In conducting these tests, specific modules are selected for their physical properties so that the certifications can be broadly applied. The following lists the specific modules that were tested and the applicability of those certifications to other modules that might come onto the market. PV modules may have a reduced mechanical load rating, independent of the SM load rating. Please consult the PV module manufacturer’s installation guide for more information.

In addition to UL 2703 certification, Unirac performs internal testing beyond the requirements of certification tests in order to establish system functional limits, allowable loads, and factors of safety. These tests include functional system tests, and destructive load testing.

MECHANICAL LOAD TEST MODULES

The modules selected for UL 2703 mechanical load testing were selected to represent the broadest range possible for modules on the market. The tests performed cover the following basic module parameters:

Frame thicknesses greater than or equal to 1.0 mm

Basic single and double wall frame profiles (some complex frame profiles could require further analysis to determine applicability)

Clear and dark anodized aluminum frames`

Tested Modules			
Module Manufacturer	Model/Series	Area [sqft]	UL2703 Certification Load Ratings
Hyundai	HiS-S325TI	21.06	Down- 113 PSF, Up - 50 PSF Down-Slope - 15 PSF
SunPower	SPR-P19-395-COM	22.20	Down- 113 PSF, Up - 50 PSF Down-Slope - 15 PSF
First Solar	FS-6xxx-P	27.12	Down- 33.9 PSF, Up - 33.9 PSF Down-Slope - 16.5 PSF
Q Cells	Q Peak Duo XL-G11.3/BFG	29.49	Down: 31.18 PSF, Up: 31.18 PSF, Down-Slope: 9.8 PSF
Trina	TSM-DEG21C.20	33.43	Down: 27.79 PSF, Up: 28.05 PSF, Down-Slope: 9.8 PSF

SYSTEM LEVEL FIRE CLASSIFICATION

The system fire class rating requires installation in the manner specified in the GFT Flush Mount Installation Guide. GFT Flush Mount has been classified to the system level fire portion of UL2703. GFT Flush Mount has achieved system level performance for steep sloped roofs and low sloped roofs. See table below for definition of steep sloped and low sloped roofs. The system is to be mounted over fire resistant roof covering rated for the application. There is no required minimum or maximum height limitation above the roof deck to maintain the system fire rating for GFT Flush Mount. Module Types, System Level Fire Ratings, & Mitigation Requirements are listed below:

ROOF TYPE	Module Fire Type	System Level Fire Rating	Rail Direction	Module Orientation	Mitigation Required
Steep Slope - roof pitches \geq 2 in/ft	1, 2, 3 with metal frame, 10 with metal frame, 19, 22, 25, 29, 30, & 38	Class A	Parallel OR Perpendicular to Ridge	Landscape OR Portrait	None Required
Low Slope - roof pitches < 2in/ft	Type 1, 2, 29, 30 & 38	Class A	Parallel OR Perpendicular to Ridge	Landscape OR Portrait	None Required

This racking system may be used to ground and/or mount a PV module complying with UL1703 or UL61730 only when the specific module has been evaluated for grounding and/or mounting in compliance with the included instructions.

Electrical Bonding and Grounding Test Modules

The list below is not exhaustive of compliant modules but shows those that have been evaluated and found to be electrically compatible with the GFT Flush Mount system.

Manufacture	Module Model / Series	Manufacture	Module Model / Series	Manufacture	Module Model / Series
Aionrise	AION60G1 AION72G1	Bluesun Solar	HEX5 BSMxxxM10-54HPH BSMxxxM10-72HBD	Canadian Solar (Cont.)	CS7N-xxx MS CS7N-xxxTB-AG ELPS CS6(A/P)-MM
Aleo	P-Series & S-Series	Boviet Solar	BVM6610 BVM6610M-xxxS-H-HC BVM6610M-xxxS-H-HC-BF BVM6612 BVM6612M-xxxS-H-HC-BF-DG BVM7612M-H-HC-BF-DG	Centrosolar America	C-Series & E-Series
Aptos Solar	DNA-144-BF10-xxxW-DG DNA-120-(MF/BF)10-xxxW DNA-120-MF10 DNA-120-(MF/BF)23 DNA-144-(MF/BF)23 DNA-120-(MF/BF)26 DNA-144-(MF/BF)26 DNA-108-(MF/BF)10-xxxW	BYD	P6K & MHK-36 Series	CertainTeed	CT2xxMxx-01 CT2xxPxx-01 CTM10400HC11-06 CTM10400HC11-08 CTM10400HC11-09 CTTCxxxHC12-08 CTxxxHC11-04 CTxxxHC11-06 CTxxxMxx-01 CTxxxMxx-02 CTxxxMxx-03 CTxxxMxx-04 CTxxxPxx-01
Astronergy	ASM6612P Series CHSM6612 M, M/HV CHSM6612P/HV Series CHSM6612P Series CHSM66M(DG)/F-BH CHSM72M(DG)/F-BH CHSM72M-HC	Canadian Solar	CS1(H/K/U/Y)-MS CS3K-(MB/MB-AG/MS/P/P HE/PB-AG) CS3L-(MS/P), CS3N-MS CS3U-(MB/MB-AG/MS/P/P HE/PB/PB-AG) CS3W-(MS/MB-AG/P/P-PB-AG) CS3Y-MB-AG CS5A-M CS6.1-54TM-H CS6.1-60TM-H CS6.1-72TB-H CS6.2-66TB-xxxH CS6K-(M/MS/MS AllBlack/P/P HE) CS6P-(M/P) CS6R-MS CS6R-xxxMS-HL CS6U-(M/P/P HE) CS6W-(MS/MB-AG) CS6W-xxx-TB-AG CS6X-P, CSX-P CS7L-MB-AG CS7L-TB-AG CS7N-xxxMB-AG	Eco Solargy	Orion 1000 & Apollo 1000
Auxin	AXN10Mxxx AXN6M610T AXN6M612T AXN6P610T AXN6P612T AXNG1M SERIES			EMMVEE	ExxxHCBG144-T ExxxHCBT144-T ExxxH CM120-B ExxxM72-B ExxxP72-B Titanium Clear
Axitec	AC-xxx(M/P)/60S AC-xxx(M/P)/72S AC-xxxMH/120(S/V/SB/VB) AC-xxxMH/144(S/V/SB/VB) AC-xxxP/156-60S AC-xxxTGB/144TS			Energy America	ZLK-xxx
				ET Solar	ET AC Module, ET Module ET-M772BH520-550WW/WB ET-M772BHxxxTW/TB
				First Solar	FS-6XXX(A) FS-6XXX(A)-P FS-6XXX(A)-P-I

- Unless otherwise noted, all modules listed above include all wattages and specific models within that series. Variable wattages are represented as "xxx"
- Items in parenthesis are those that may or may not be present in a compatible module's model ID
- Slashes "/" between one or more items indicates that either of those items may be the one that is present in a module's model ID
- The frame profile must not have any feature that might interfere with the bonding devices that are integrated into the racking system
- Use with a maximum over current protection device OCPD of 30A
- **Listed models can be used to achieve a Class A fire system rating for steep slope and low slope applications. See page 27**

Electrical Bonding and Grounding Test Modules

The list below is not exhaustive of compliant modules but shows those that have been evaluated and found to be electrically compatible with the GFT Flush Mount system.

Manufacture	Module Model / Series	Manufacture	Module Model / Series	Manufacture	Module Model / Series						
Flextronics	FXS-xxxBB	Hyundai	HiA-SxxxHG HiD-SxxxRG(BK) HiN-SxxxXG(BK) HiN-TxxxNF(BK) HiN-TxxxNI HiN-TxxxNJ HiN-TxxxOJ HiS-S400PI HiS-SxxxGI HiS-SxxxOJ HiS-SxxxXG(BK) HiS-SxxxYH(BK) HiS-TxxxNF(BK) HiS-TxxxNJ KG, MG, RW, TG, RI, RG, TI, KI, HI Series	JA Solar	JAM54D41-xxx/MB JAM54S30 xxx/MR JAM54S31 xxx/MR JAM6(K)-60/xxx JAM66D45 LB JAM72D10 xxx/MB JAM72D30MB JAM72D40 xxx/MB JAM72S30 /MR JAM78D10MB JAP6(k)-72-xxx/4BB JAP6 60-xxx						
Freedom Forever	FF-MP-BBB-xxx, FF-MP1-BBB-xxx		Illuminate USA		IL5-72HBD-xxx M IL8-66HGD-xxx M	Jinko	JKM & JKMS Series JKMxxxM-6RL3-B JKMxxxM-72HBL-V JKMxxxM-72HL4-(T)V JKMxxxM-72HL4-TV JKMxxxM-72HLM-TV JKMxxxM-72HL-V JKMxxxM-7RL3-TV JKMxxxM-7RL3-V JKMxxxN-54HL4-B JKMxxxN-72HL4-BDV JKMxxxN-72HL4-BDX JKMxxxN-72HL4-TV				
FreeVolt	PVGraf				Imperial Star			ISM7-SHDD108-400/M			
GCL	GCL-P6 & GCL-M6 Series		Inception		mSolar 108BB HC Series (TX110-xxx108BB) mSolar 144BB HC Series (TXS6-xxx144BB)			Kyocera	KD-F & KU Series		
Hansol	TD-AN3, TD-AN4 UB-AN1, UD-AN1		ITEK		iT-SE Series						
Hanwha SolarOne	HSL 60		Japan Solar		JPS-60 & JPS-72 Series			LA Solar LA Solar LA Solar LA Solar LA Solar LA Solar	LSxxxBF (530-550 watt range) LSxxxBL (410 watt) LSxxxBL (430-450 watt range) LSxxxBL (530-550 watt range) LSxxxHC(166), LSxxxBF, LSxxxBL LSxxxHC (430-450 watt range) LSxxxHC, BLA Model		
Heliene	36M, 36P 60M, 60P, 72M & 72P Series 144HC M6 132HC M10 SL Monofacial 144HC M10 SL Bifacial 156HC M10 SL Bifacial		JA Solar		JAP72S##-xxx/** JAP6(k)-60-xxx/4BB, JAP60S##-xxx/** JAM6(k)-72-xxx/**, JAM72S##-xxx/** JAM6(k)-60-xxx/**, JAM60S##-xxx/** i. ##: 01, 02, 03, 09, 10 ii. **: SC, PR, BP, HiT, IB, MW, MR ** = Backsheet, ## Cell technology						
										HT-SAAE	HT60-156M-C HT60-156M(V)-C HT72-156(M/P) HT72-156P-C, HT72-156P(V)-C HT72-156M(PDV)-BF, HT72-156M(PD)-BF HT72-166M, HT72-18X

- Unless otherwise noted, all modules listed above include all wattages and specific models within that series. Variable wattages are represented as "xxx"
- Items in parenthesis are those that may or may not be present in a compatible module's model ID
- Slashes "/" between one or more items indicates that either of those items may be the one that is present in a module's model ID
- The frame profile must not have any feature that might interfere with the bonding devices that are integrated into the racking system
- Use with a maximum over current protection device OCPD of 30A
- **Listed models can be used to achieve a Class A fire system rating for steep slope and low slope applications. See page 27**

Electrical Bonding and Grounding Test Modules

The list below is not exhaustive of compliant modules but shows those that have been evaluated and found to be electrically compatible with the GFT Flush Mount system.

Manufacture	Module Model / Series	Manufacture	Module Model / Series	Manufacture	Module Model / Series
LG Electronics	LGxxx(E1C/E1K/N1C/N1K/N2T/N2W/S1C/S2W/Q1C/Q1K)-A5 LGxxx(A1C/M1C/M1K/N1C/N1K/Q1C/Q1K/QAC/QAK)-A6, LGxxxN2W-B3 LGxxxN2T-B5, LGxxxN1K-B6 LGxxx(N1C/N1K/N2T/N2W)-E6 LGxxx(N1C/N1K/N2W/S1C/S2W)-G4 LGxxxN2T-J5, LGxxx(N1K/N1W/N2T/N2W)-L5 LGxxx(M1C/N1C/Q1C/Q1K)-N5 LGxxx(N1C/N1K/N2W/Q1C/Q1K)-V5 LGxxxN3K-V6	Meyer Burger	Meyer Burger Black Meyer Burger White Meyer Burger Glass	Panasonic	EVPVxxx EVPVxxx(H/K/PK/HK/HK2) VBHNxxxKA VBHNxxxKA03/04 VBHNxxxSA06/SA06B/SA11/SA11B VBHNxxxSA15/SA15B/SA16/SA16B VBHNxxxSA17/SA17G/SA17E/SA18/SA18E VBHNxxxZA01/ZA02/ZA03/VBHNxxxZA04
LONGi	LR4-60(HPB/HPH) LR4-72(HPH) LR4-72HBD xxxM LR5-54HABB-xxx M (fire type 29 only) LR5-54-HPB-xxxM LR5-54HTB xxxM LR5-72HBD xxx M LR6-60 LR6-60(BK/HPB/HPH/HV/PB/PE/PH) LR6-72 LR6-72(BK/HV/PB/PE/PH) LR7-72HGD-xxx M LR8-54HGBB LR8-66HGD-xxx M RealBlack LR4-60HPB RealBlack LR6-60HPB	Mission Solar Energy	MSE Mono, MSE Perc MSExxx(SR8T/SR8K/SR9S/SX5T) MSExxx(SX5K/SX6W) MSExxxHT0B MSExxxSX6Z MSExxxSX9R MSExxxSX9R MSH10-xxxHN4G MSH10-xxxHT4T MSI10-xxxHN4G MSI10-xxxHT4G MSI10-xxxHT4T MSN10xxxHT4T MSX10-xxxHN0B	Peimar	SGxxxM (FB/BF) SMxxxM
Maxeon	SPR-MAX3-xxx-BLK-R SPR-MAX3-xxx-COM SPR-MAX3-xxx-R SPR-MAX6-xxx SPR-MAX6-xxx-BLK	Mitrex	Mxxx-L3H Mxxx-I3H	Philadelphia Solar	PS-M108(HCBF)-400W (30 & 35mm frames) PS-M144(HCBF)-xxxW PS-MNB108(HCBF)-xxxW PS-MNB144(HCBF)-xxxW PS-MNB156(HCBF)-xxxW
		Mitsubishi	MJE & MLE Series	Phono Solar	PSxxxM1-20/U PSxxxM1H-20/U PSxxxM1-20UH PSxxxM1H-20UH PSxxxM4(H)-24/TH PSxxxM1-20/UH PSxxxM1H-20/UH PSxxxM-24/T PSxxxMH-24/T PSxxxM-24/TH PSxxxMH-24/TH
		mSolar	TXI10-xxx108BB	Prism Solar	P72 Series, P72X-xxx
		Neo Solar Power Co.	D6M Series		
		NE Solar	NESE xxx-60MH-M6 NESE xxx 66MHB-G12 NESE xxx-72MHB-M10 NESE xxx 72MHT-M10 NESE xxx 72THB-M10		

- Unless otherwise noted, all modules listed above include all wattages and specific models within that series. Variable wattages are represented as "xxx"
- Items in parenthesis are those that may or may not be present in a compatible module's model ID
- Slashes "/" between one or more items indicates that either of those items may be the one that is present in a module's model ID
- The frame profile must not have any feature that might interfere with the bonding devices that are integrated into the racking system
- Use with a maximum over current protection device OCPD of 30A
- **Listed models can be used to achieve a Class A fire system rating for steep slope and low slope applications. See page 27**

Electrical Bonding and Grounding Test Modules

The list below is not exhaustive of compliant modules but shows those that have been evaluated and found to be electrically compatible with the GFT Flush Mount system.

Manufacture	Module Model / Series	Manufacture	Module Model / Series	Manufacture	Module Model / Series	
Q Cells	Peak G5(SC) , G6(+)(SC)(AC), G7, G8(+), Peak L-G5, L-G6, L-G7, L-G8(BFF) Plus, Pro, Peak, G3, G4, Plus, Pro, Peak L-G2, L-G4, L-G5 Q.PEAK DUO(BLK)-G6+ Q.PEAK DUO (BLK)-G7 Q.PEAK DUO (BLK) G8(+) Q.PEAK DUO (BLK) ML-G10(a)(+) Q.PEAK DUO (BLK) ML-G9(+) Q.PEAK DUO BLK G10(+) Q.PEAK DUO BLK G10+ /AC Q.PEAK DUO BLK-G6+/TS Q.PEAK DUO BLK ML-G10+ Q.PEAK DUO BLK ML-G10.a+ Q.PEAK DUO BLK ML-G10.B+ Q.PEAK DUO BLK ML-G10.C+ Q.PEAK DUO BLK ML-G10+ / t Q.PEAK DUO BLK ML-G10+ / TS Q.PEAK DUO-G10+ QPEAK DUO G10.C1+ AC Q.PEAK DUO L-(G7/G7.1/G7.2/G7.3/G7.7) Q.PEAK DUO L-(G8/G8.1/G8.2/G8.3) Q.PEAK DUO L-G6.3 / BFG Q.PEAK DUO L-G8.3 (BFF/BFG/BGT) Q.PEAK DUO ML-G12S.3 / BFG Q.PEAK DUO ML-G12S.d / BFG Q.PEAK DUO XL-(G10/G10.2/G10.3/G10.c/ G10.d) Q.PEAK DUO XL-(G11.2/G11.3) Q.PEAK DUO XL-(G9/G9.2/G9.3) Q.PEAK DUO XL-G10.3/BFG Q.PEAK DUO XL-G10.d/BFG	Q Cells (Cont.)	Q.PEAK DUO XL-G11.3/BFG Q.PEAK DUO XL-G11S.3 / BFG Q.PEAK DUO XL-G9.3/BFG Q.TRON BLK M-G2+ Q.TRON BLK M-G2+/AC Q.TRON BLK M-G2+ AC Q.TRON BLK M-G2.C+ Q.TRON BLK M-G2.F+ Q.TRON BLK M-G2.F1+/AC Q.TRON BLK M-G2.H+ Q.TRON BLK M-G2.H1+/AC Q.TRON BLK M-G2+ SERIES Q.TRON M-G2+ SERIES Q.TRON XL-G2.3/BFG	SEG Solar	SEG-xxx-BMD-HV SEG-xxx-BMD-TB, SEG-xxx-BMB-TB SEG-xxx-BMA-HV, SEG-xxx-BMA-TB SEG-xxx-BMB-HV, SEG-xxx-BMA-BG SEG-xxx-BMB-BG, SEG-xxx-BTA-BG SEG-xxx-BTB-BG, SEG-xxx-BMD-BG SEG-xxx-BTD-BG	
	S-Energy		SN72 & SN60 Series SL45-60BGI/BHI SL45-60MBI-xxxZ			
			Seraphim		SEG-(6PA/6PB/6MA/6MA-HV/6MB/E01/E11) SRP-(6QA/6QB) SRP-320-375-BMB-HV SRP-390-405-BMD-HV SRP-390-450-BMA-HV SRP-xxx-6MB-HV SRP-xxx-BMC-HV SRP-xxx-BMZ-HV SRP-xxx-BTA-BG SRP-xxx-BTB-BG SRP-xxx-BTC-BG SRP-xxx-BTD-BG SRP-xxx-BTE-BG	
					Sharp	NU-SA & NU-SC Series
						Silfab
				REC		
	Renesola					
			Risen			

- Unless otherwise noted, all modules listed above include all wattages and specific models within that series. Variable wattages are represented as "xxx"
- Items in parenthesis are those that may or may not be present in a compatible module's model ID
- Slashes "/" between one or more items indicates that either of those items may be the one that is present in a module's model ID
- The frame profile must not have any feature that might interfere with the bonding devices that are integrated into the racking system
- Use with a maximum over current protection device OCPD of 30A
- **Listed models can be used to achieve a Class A fire system rating for steep slope and low slope applications. See page 27**

Electrical Bonding and Grounding Test Modules

The list below is not exhaustive of compliant modules but shows those that have been evaluated and found to be electrically compatible with the GFT Flush Mount system.

Manufacture	Module Model / Series	Manufacture	Module Model / Series	Manufacture	Module Model / Series
Sirius	ELNSM54M-HC-BF Series ELNSM54M-HC Series ELNSM72M-HC Series		Hipor M, Smart, TP572, TP596, TP654, TP660, TP672 TD6I72M TD7G72M TM3G48M TM3G54M TM3G66M TM7G54M TM7G60M TM7G72M TP6F72M TP6F72M(H) TP6L72M-450 TP7G54M(H)	Trina (Cont.)	TSM-NE19RC TSM-NEG19RC.20 TSM-NEG21C.20
Solar4America	S4Axxx-108MH10BB, S4Axxx-72MH5BB S4Axxx-144MH10xxx, S4Axxx-144TH10xxx S4Axxx-144TH16xxx, S4Axxx-108MH10xxx S4Axxx-108TH10xxx	Talesun		TSMC	TS-150C2 CIGSw
SolarEver USA	SE-166*83-xxxM-120N SE-182*105-xxxM-96-BD SE-182*91-xxxM-108N			Universal Solar	UNI4xx-144BMH-DG UNI5xx-144BMH-DG UNIxxx-108M-BB UNIxxx-120M-BB UNIxxx-120MH
Solaria	PowerXT-xxxR-(AC/PD/BD) PowerXT-xxxC-PD PowerXT-xxxR-PM (AC) PowerX-400R	Tesla	SC, SC B, SC B1, SC B2, TxxxS, TxxxH	Upsolar	UP-MxxxP UP-MxxxM(-B)
Solartech	STU HJT, STU PERC & Quantum PERC	Thornova	TS-BG54 TS-BG72 TS-BBT54(xxx) TS-BGT72(xxx)	URECO	D7Kxxx(H7A/H8A), D7Mxxx(H7A/H8A) F6MxxxE7G-BB FAKxxx(C8G/E8G), FAMxxxE7G-BB FAMxxxE8G(-BB), FBKxxxM8G FBMxxxM7G-BB FBMxxxMFG-BB
SolarWorld	Sunmodule Protect, Sunmodule Plus/Pro			Vikram Solar	Eldora, Somera, Ultima PREXOS VSM DHT.60.AAA.05 PREXOS VSM DHT.72.AAA.05 Paradea VSM DHT.72.AAA.05
Sonali	SS-M-360 to 390 Series SS-M-390 to 400 Series SS-M-440 to 460 Series SS-M-430 to 460 BiFacial Series	Trina	DE09C.07 DEG15HC.20(II), DEG15MC.20(II) DEG15VC.20(II), DE18M(II), DEG18MC.20(II) DE19, DEG19C.20 PA05, PD05, DD05, DD06, DE06, DE09.05 PD14, PE14, DD14, DE14, DE15, DE15V(II) TSM-DE06X.05(II) TSM-DE09.05 TSM-DE09.08 TSM-DE09C.07 TSM-DEG21C.20 TSM-NE09RC.05, TSM-NE09RH.05	Vina	VNS-72M1-5-xxxW-1.5 VNS-72M3-5-xxxW-1.5 VNS-144M1-5-xxxW-1.5 VNS-144M3-5-xxxW-1.5 VNS-120M3-5-xxxW-1.0
Sun Edison	F-Series, R-Series				
Suniva	MV Series & Optimus Series (35mm)				
Sunmac Solar	M754SH-BB Series				
SunPower	AC, X-Series, E-Series & P-Series SPR E20 435 COM (G4 Frame) Axxx-BLK-G-AC, SPR-Mxxx-H-AC SPR-Mxxx-H-AC, SPR-Mxxx-BLK-H-AC				
SunPro	SPDGxxx-120M12				
SunTech	STP, STPXXXS - B60/Wnhb				

- Unless otherwise noted, all modules listed above include all wattages and specific models within that series. Variable wattages are represented as "xxx"
- Items in parenthesis are those that may or may not be present in a compatible module's model ID
- Slashes "/" between one or more items indicates that either of those items may be the one that is present in a module's model ID
- The frame profile must not have any feature that might interfere with the bonding devices that are integrated into the racking system
- Use with a maximum over current protection device OCPD of 30A
- **Listed models can be used to achieve a Class A fire system rating for steep slope and low slope applications. See page 27**

Electrical Bonding and Grounding Test Modules

The list below is not exhaustive of compliant modules but shows those that have been evaluated and found to be electrically compatible with the GFT Flush Mount system.

Manufacture	Module Model / Series
VSUN	VSUN4xx-144BMH VSUN4xx-144BMH-DG VSUN5xx-144BMH-DG VSUNxxx-108BMH VSUNxxx-108M-BB VSUNxxx-108MH VSUNxxx-120BMH VSUNxxx-120M-BB VSUNxxx-132BMH VSUNxxx-144BMH VSUNxxx-144M-BB VSUNxxx-144M-BW VSUNxxx-144MH VSUNxxx-60M-BB VSUNxxx-72MH VSUNxxxN-108BMH-BB VSUNxxxN-108BMH-BB (SoftPaw) VSUNxxxN-120BMH-BB (SoftPaw) VSUNxxxN-144BMH VSUNxxxN-144MH
Waaree	Ahnay Series Bi-33 Arka Series WSMDi
Winaico	WST & WSP Series
Yingli	YGE & YLM Series
Yotta Energy	YSM-B450-1

Manufacture	Module Model / Series
ZNShine	ZXM6-72 Series ZXM6-NH120 Series ZXM6-NH144 ZXM6-NHLDD144 ZXM7-SH108 Series ZXM7-SHDB144 ZXM7-SHLDD144 ZXM7-UHLDD144 ZXM8-TPLDD132

- Unless otherwise noted, all modules listed above include all wattages and specific models within that series. Variable wattages are represented as "xxx"
- Items in parenthesis are those that may or may not be present in a compatible module's model ID
- Slashes "/" between one or more items indicates that either of those items may be the one that is present in a module's model ID
- The frame profile must not have any feature that might interfere with the bonding devices that are integrated into the racking system
- Use with a maximum over current protection device OCPD of 30A
- **Listed models can be used to achieve a Class A fire system rating for steep slope and low slope applications. See page 27**